



PROJECT NAME: _____

LOCATION: _____

ITEM: _____ QTY: _____

MODEL: _____

SR-6-36CO CONVECTION OVEN RANGE SR SERIES (OPEN BURNERS)

Sierra series convection oven range is 100% manufactured from raw materials to provide the best cooking experience, a high standard of quality, and the highest durability in its class to meet the needs of a commercial kitchen.

With its six 25,000-BTU burners, this unique Sierra SR-6-36CO commercial range is great for cooking several pots or pans simultaneously. And baking will be better than ever with convection built-in! Cast iron grates on the burners transmit heat efficiently to the pan from the burner. Beneath the burners is a crumb tray that catches and contains loose food matter.

SR-6-36CO

Unit shown with optional casters. Unit ships with legs as standard



STANDARD FEATURES

RANGE

- Available in 36" (915 mm) width.
- Stainless steel front and sides.
- 12" x 12" cast iron top grates designed for easy movement of pots across top sections.
- Landing ledge, promoting safety and great functionality.
- Orange paint injected aluminum knobs providing for better toughness and durability.
- Easily removable stainless steel crumb/drip pan.

OVEN

- 35,000 BTU/h oven with snap action thermostat from 210° F to 550° F and 100% safety shut off.
- Dynamic airflow technology (DAT) a patented convection oven with balanced airflow a low profile fan, 26 1/2" oven depth.
- Convection oven base that fits a full-size sheet pan on all models.
- The convection oven has an on/off switch and high/low fan speed.
- Double-sided enamel oven cavity (Interior top, bottom, and sides).
- Heavy-duty wire oven rack - 1/8" diameter.
- The convection oven has 3 shelf positions and 1 rack.
- Counterweight balanced doors.
- Units are shipped ready for natural gas (NG). A propane gas (LP) conversion kit and NG/LP regulator is supplied with the unit.

ACCESSORIES/OPTIONAL

- (4) 6" swivel casters with front locking brakes.
- Additional oven rack.

SR36CO05172022



www.mvpgroupcorp.com



3560 NW 56th Street
Fort Lauderdale, FL 33309
Tel.: 786.600.4687 / Toll Free: 844.218.8477
Fax.: 786.661.4100



5659 Royalmount Avenue
Montreal, Qc, Canada H4P 2P9
Tel.: 514.737.9701 / Toll Free: 888.275.4538
Fax.: 514.342.3854 / Toll Free: 877.453.8832

sales@mvpgroupcorp.com



TECHNICAL DRAWINGS

CONVECTION OVEN RANGE SR SERIES (OPEN BURNERS)
SR-6-36CO

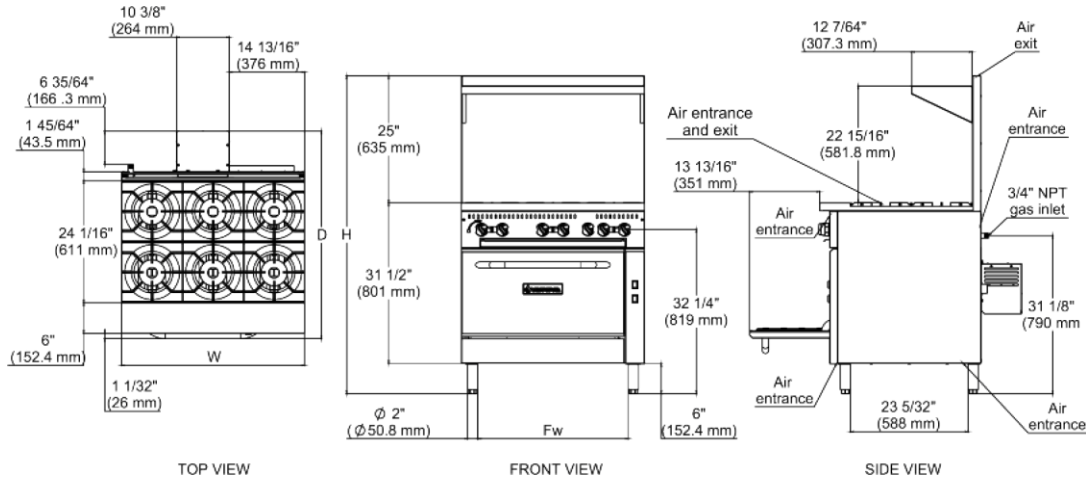

SPECIFICATIONS

Models	Exterior Product Dimensions & Weight					Shipping Crate Dimensions & Weight				Oven - Inside			
	Width (W)	Depth (D)	Height (H)		Fw	Weight	Width	Depth	Height	Weight	Width	Depth	Height
			P.B	P.S									
SR-6-36CO	36" (915 mm)	40 15/16" (1040 mm)	41 17/64" (1048 mm)	62 33/64" (1588 mm)	29 39/64" (752 mm)	498 lb (226 kg)	40 35/64" (1030 mm)	45 43/64" (1160 mm)	47 3/64" (1195 mm)	529 lb (240 kg)	26 31/32" (685 mm)	26 1/2" (673 mm)	15 23/64" (390 mm)

UTILITY INFORMATION

GAS SUPPLY								
Models	Burners (Range)	Propane	Natural	Burners (Oven)	Propane	Natural	Manifold Pressure	
		BTU/h	BTU/h		BTU/h	BTU/h	Natural Gas	Propane Gas
SR-6-36CO	6	150,000	150,000	1	33,000	35,000	4" W.C.	10" W.C.

ELECTRICAL								
Motor Speed (RPM)	Voltage (V)	Frequency (Hz)	Motor rated current (A)	Electric Motor Power (W)	Lamp Power (W)	Total Electric Power (W)	Electric Consumption (kWh)	Circuit Breaker (A)
LOW (1125 rpm)	115	60	3.3	371.91	25	396.91	0.40	15 A
HIGH (1725 rpm)			3.7	380.38	25	405.38	0.41	

- Manifold pressure is 4" W.C (natural gas) or 10" W.C (propane gas).
 - 3/4" NPT rear gas connection and pressure regulator for both natural gas and propane.
 - Check the altitude specifications above 2,000 ft.
- * NOTE: In line with its policy to continually improve its product, Sierra reserves the right to change materials and specifications without notice.

INSTALLATION INSTRUCTIONS

A pressure regulator sized for this unit is included. The gas line connecting to the range must be 3/4" or larger. If flexible connectors are used, the inside diameter must be 3/4" or larger. An adequate ventilation system is required for commercial cooking equipment. Information may be obtained by writing to the National Fire Protection Association, 1 Batterymarch Park, Quincy, MA 02269, www.NFPA.org. When writing, refer to NFPA No. 96.4. These units are manufactured for installation in accordance with ANSZ223.1A (latest edition), National Fuel Gas Code. Copies may be obtained from The American Gas Association, 400 N Capitol St. NW, Washington, DC 20001, www.AGA.org.

Warranty: 12 months parts & labor. See Sierra Price List for full details.

Gas Connection: 3/4" NPT on the right hand rear of the appliance. The pressure regulator (supplied) is to be connected here by the installer.

Gas pressure: 4"W.C. - Natural Gas | 10"W.C. - Propane.

Combustible Clearances: For use in non-combustible locations | Non-combustible Clearances: 0 inches sides, 0 inches rear Specify type of gas and altitude, if over 2,000 feet, when ordering.

SIERRA is a registered trademark of MVP Group.

Due to continuing product development, to ensure best possible performance, the specifications are subject to change without prior notice.



www.mvpgroupcorp.com



3560 NW 56th Street
Fort Lauderdale, FL 33309
Tel.: 786.600.4687 / Toll Free: 844.218.8477
Fax.: 786.661.4100



5659 Royalmount Avenue
Montreal, Qc, Canada H4P 2P9
Tel.: 514.737.9701 / Toll Free: 888.275.4538
Fax.: 514.342.3854 / Toll Free: 877.453.8832

sales@mvpgroupcorp.com