



Self-Cleaning Rotisserie Oven

including Optional Holding Cabinet

AR-7T
AR-7HT



MN-39243

REV. 03
6/23

EN

For the most current manual, visit alto-shaam.com
Die neueste Fassung des Handbuchs finden Sie auf alto-shaam.com
Pour la dernière version du manuel, visitez alto-shaam.com
Para obtener el manual más actual, visite alto-shaam.com
Ga voor de meest recente handleiding naar alto-shaam.com
За самой последней версии руководства обращайтесь на сайт alto-shaam.com
要查看当前最新手册, 请访问 alto-shaam.com



Manufacturer's Information

Copyright

© Copyright 6/23 by Alto-Shaam, Inc.

All rights reserved.

This manual or any portion thereof may not be reproduced or used in any manner whatsoever without the express written permission of Alto-Shaam, Inc.

Trademarks

All trademarks referenced in this documentation are the property of their respective owners.

Manufacturer

Alto-Shaam, Inc.

P.O. Box 450

W164 N9221 Water Street

Menomonee Falls, WI 53052

Original instructions

The content in this manual is written in American English.

Alto-Shaam 24/7 Emergency Repair Service

Call	Call 800-558-8744 to reach our 24-hour emergency service call center for immediate access to local authorized service agencies outside standard business hours. The emergency service access is provided exclusively for Alto-Shaam equipment and is available throughout the United States through Alto-Shaam's toll free number.
Availability	Emergency service access is available seven days a week, including holidays.

This page is intentionally left blank.

Manufacturer’s Information 2

Foreword 3

Alto-Shaam 24/7 Emergency Repair Service 3

Safety 7

The Meaning of Signal Words 7

Appliance Description and Intended Use. 8

Safety Precautions. 9

Operation 13

How to Turn On and Turn Off the Oven13

How to Update the Software.14

How to Restore Factory Defaults16

How to Calibrate the Screen18

How to Turn On and Turn Off the Holding Cabinet20

How to Operate the Holding Cabinet21

How to Select the Cleaning Method.22

How to Use the Service Screen23

Components 27

Exterior Panels.27

Left Service Panel28

Left Service Panel Components29

Control Panel33

Control Panel Components.34

Right Service Panel36

Electrical Chassis — 208-240 volt, 1 phase37

Electrical Chassis — 208-240 volt, 3 phase38

Electrical Chassis — 380-415 volt, 3 phase39

Electrical Chassis Components40

Maintenance 49

Maintenance Schedule49

How to Clean the Oven Using Liquid Cleaner51

How to Clean the Oven Using Tablets53

How to Clean and Inspect the Humidity Valve.56

Troubleshooting 59

AR-7T Error Codes.59

AR-7HT Error Codes61

The Oven will not Power Up62

The Oven will not Heat64

Spit Motor Inoperable65

Convection Fan Motor Inoperable.66

Wash Pump Inoperable 67
Drain Pump Inoperable 68
Grease Collection Pump Inoperable 69
Liquid Cleaner Pump Inoperable 70
The Oven Water Heater will not Heat 71
The Oven Overflows the Front Drip Tray. 72

Schematics **73**

The Meaning of Signal Words

This manual contains signal words where needed. These signal words must be obeyed to reduce the risk of death, personal injury, or equipment damage. The meaning of these signal words is explained below.

**DANGER**

Danger indicates a hazardous situation which, if not avoided, will result in serious injury or death.

**WARNING**

Warning indicates a hazardous situation which, if not avoided, could result in serious injury or death.

**CAUTION**

Caution indicates a hazardous situation which, if not avoided, could result in minor or moderate injury.

NOTICE

Notice indicates a situation which, if not avoided, could result in property damage.



NOTE: Note indicates additional information that is important to a concept or procedure.

Appliance Description and Intended Use

Appliance Description

This Alto-Shaam rotisserie oven is an electric-powered oven with programmable touchscreen control that includes multi-level cooking for preheat, cooking, holding, and cool-down stages. It includes a self-cleaning wash system with built-in sanitizing cycle. Seven angled spits are included; a variety of spits are offered as options. Double-pane glass door available in curved or flat options. USB port for recipe upload and download.

Intended use

The rotisserie oven is intended to cook, hold or process foods for the purpose of human consumption. No other use for this appliance is authorized. This appliance is intended to be used for commercial applications, for example in kitchens of restaurants, canteens, hospitals and in commercial enterprises such as bakeries, butcheries, etc., but not for continuous mass production of food.

Residual risks

This appliance is manufactured using ISO-certified processes. The appliance is designed with maximum safety in mind; however, there are residual risks to operators of this oven. Residual risks include exposure to heat and exposure to hot food products.

Possible misuse

Misuse of this appliance includes cooking food containing flammable materials (such as food with alcohol). Substances with a low flash point can ignite spontaneously and cause a fire.

Safety Precautions

Before you begin

Read and understand all instructions in this manual.

Electrical precautions

Obey these electrical precautions when using the appliance:

- Various electrical configurations of the rotisserie are available. Always match the power source with the power rating on the rotisserie's data tag.
 - Use one (1) dedicated circuit per rotisserie.
 - Use a junction box or electrical disconnect within 3' (914mm) of rotisserie.
 - Keep the cord away from hot surfaces.
 - Electrical connections and circuit breakers must meet all applicable federal, state and local codes.
 - Do not let the cord hang over the edge of a table or counter.
-

Usage precautions

Obey these usage precautions when using the appliance:

- Only use this appliance for its intended use of cooking or heating.
 - Do not load liquids, or foods that can become liquid when heated, into the rotisserie.
 - Use utensils and protective clothing when loading and unloading the appliance.
 - Use caution when using the appliance. Floors adjacent to the appliance may become slippery.
 - Use caution when opening the appliance door. Escaping hot vapors or steam can cause serious injury.
 - Do not open the door of the rotisserie during the cleaning cycle.
 - Do not cover or block any of the openings of this appliance.
 - Do not use this appliance near water such as a sink, in a wet location, near a swimming pool, or similar locations.
-

Maintenance precautions

Obey these maintenance precautions when maintaining the appliance:

- Obey precautions in the manual, on tags, and on labels attached to or shipped with the appliance.
- The appliance must be cleaned thoroughly to prevent deposits of grease and food residue inside the appliance that may catch fire.
- Do not place combustible materials in the appliance.
- Do not store the appliance outdoors.
- Do not clean the appliance with metal scouring pads.
- Do not use a hose, water jet, or steam cleaner to clean the appliance.
- Do not store or use any flammable substances near the appliance.
- For users only: Do not remove the top cover or side panels. There are no user-serviceable components inside.

Caster precautions

Obey these precautions if the appliance is installed on casters.

- Restrict movement of the appliance with a tether so that utility connections (water and electricity) are not damaged.
 - Disconnect all utility connections when moving the appliance.
 - Only use this appliance when it is stationary.
 - Use caution when using the appliance on uneven floors. Mobile appliances and accessories can roll or tip over and cause serious injury or property damage.
 - Lock the caster brakes on mobile appliances or accessories when they are not being moved.
-

Operator training

All personnel using the appliance must have proper operator training. Before using the appliance:

- Read and understand the operating instructions contained in all the documentation delivered with the appliance.
 - Know the location and proper use of all controls.
 - Keep this manual and all supplied instructions, diagrams, schematics, parts lists, notices, and labels with the appliance if the appliance is sold or moved to another location.
 - Contact Alto-Shaam for additional training if needed.
-

Operator qualifications

Only trained personnel with the following operator qualifications are permitted to use the appliance:

- Have received proper instruction on how to use the appliance.
- Have demonstrated their ability with commercial kitchens and commercial appliances.

The appliance must not be used by:

- Persons (including children) with reduced physical, sensory or mental capabilities, or lack of experience and knowledge, unless they have been given supervision concerning use of the appliance by person responsible for their safety.
 - People impaired by drugs or alcohol.
-

- Children should be supervised to ensure that they do not play with the appliance.
 - Children shall neither clean nor maintain the appliance.
-

Condition of appliance

Only use the appliance when:

- All controls operate correctly.
- The appliance is installed correctly.
- The appliance is clean.
- The appliance labels are legible.

Servicing the appliance

- Only trained personnel are permitted to service or repair the appliance. Repairs that are not performed by an authorized service partner or trained technician, or the use of non-factory parts, will void the warranty and relieve Alto-Shaam of all liability.
 - To prevent serious injury, death or property damage, have the appliance inspected and serviced at least every twelve (12) months by an authorized service partner or trained technician.
 - Contact Alto-Shaam for the authorized service partner in your area.
-

Personal Protective Equipment (PPE)

Wear the following Personal Protective Equipment (PPE) while cleaning the appliance:

- Protective gloves
- Protective clothing
- Eye protection
- Face protection

This page is intentionally left blank.

How to Turn On and Turn Off the Oven

Before you begin

The oven must be connected to electric power.

Turning on the oven

To turn on the oven, do the following.

Step	Action
------	--------

1. **Set** the power switch to the ON (I) position ①.

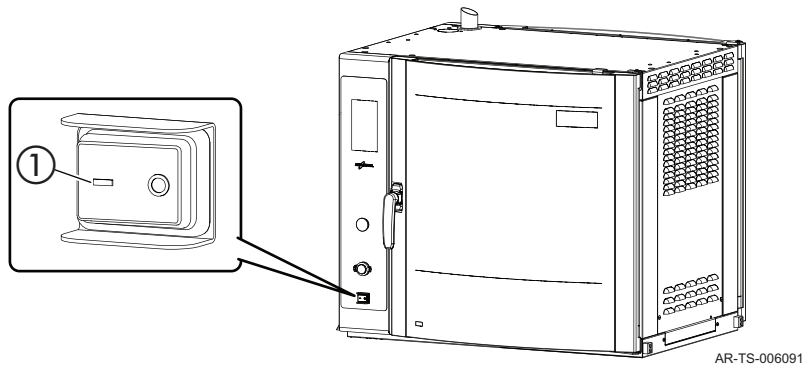

The oven is now on.

Turning off the oven

To turn off the oven, do the following.

Step	Action
------	--------

1. **Set** the power switch to the OFF (O) position.

The oven is now off.

How to Update the Software

Before you begin

Make sure:

- The oven is turned on.
- The oven is idle and not currently in a cook or clean sequence.
- You do not remove the USB drive during the update process.
- You have a USB drive with the updated firmware.

Procedure

To update the software, do the following.

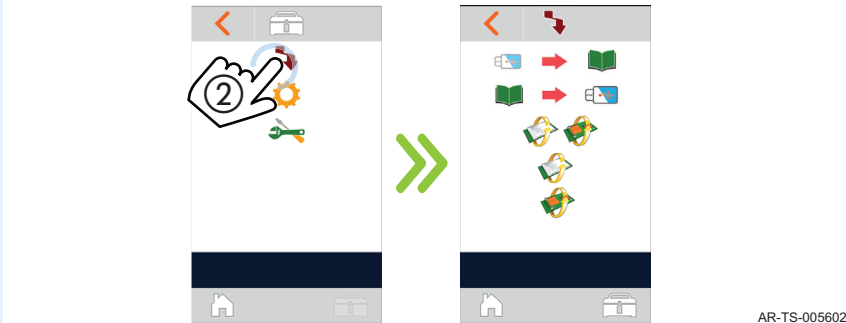
Step	Action
1.	<p>Touch the utilities icon ①. The utilities screen displays.</p>  <p style="text-align: right;">AR-TS-005599</p>
2.	<p>Touch the upload/download icon ②. The upload/download screen displays.</p>  <p style="text-align: right;">AR-TS-005602</p>

Continued on next page

Continued from previous page

3. **Insert** the USB drive into the port ③.

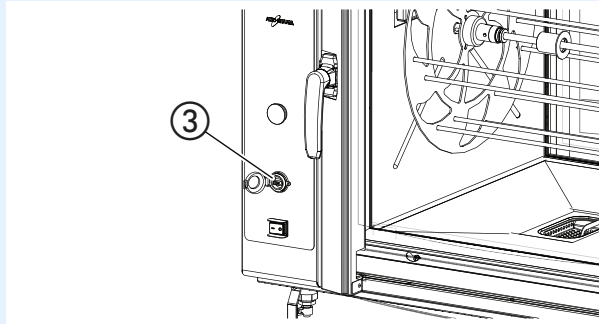

AR-TS-005774

NOTICE Do not remove the USB drive during the update process.

4. **Touch** the download new software icon ③ for the full oven update.
- To update only the interface board, **touch** the interface board icon ④.
 - To update only the control board, **touch** the control board icon ⑤.

i NOTE: After the software has been updated, the oven may automatically initiate a shut down and reboot sequence if required.

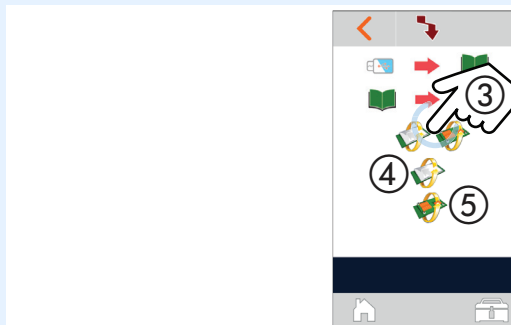

AR-TS-005611

5. **Remove** the USB drive.

Result

The oven's software has been updated.

How to Restore Factory Defaults

Before you begin

Make sure the oven is turned on.

Procedure

To restore factory defaults, do the following.

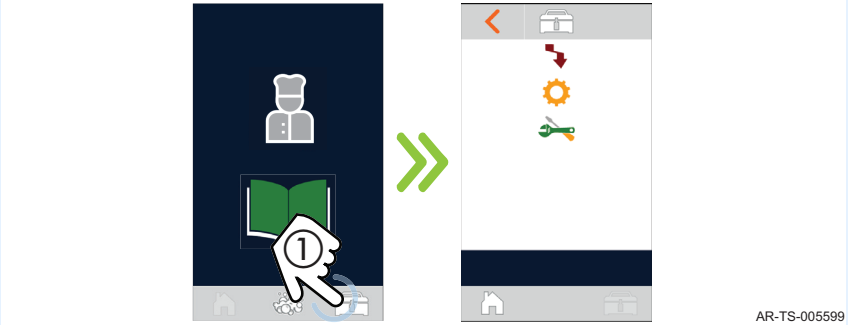
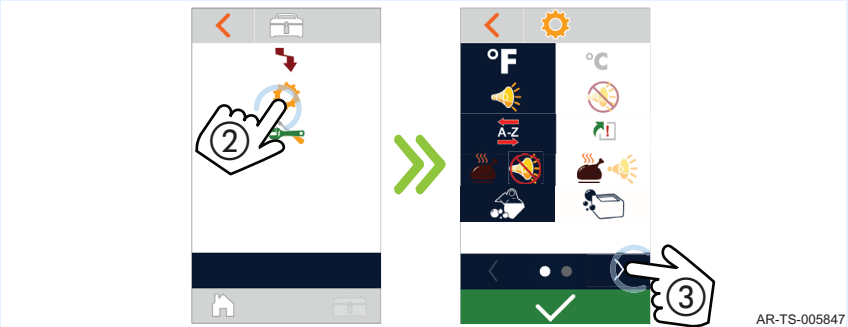
Step	Action
1.	<p>Touch the utilities icon ①. The utilities screen displays.</p>  <p style="text-align: right;">AR-TS-005599</p>
2.	<p>Touch the settings icon ②. The settings screen displays.</p> <p>Touch the arrow icon ③ to view the second settings screen.</p>  <p style="text-align: right;">AR-TS-005847</p>

Continued on next page

Continued from previous page

3. **Touch** the restore factory defaults icon ④. The restore factory defaults screen displays.



4. **Touch** the green check mark icon ⑤.



NOTE: All saved recipes will be deleted.

The screen will go blank for a moment. The start-up screen will appear briefly, then the display will return to the Home screen.

Result

The factory defaults have been restored.

How to Calibrate the Screen

Before you begin

Make sure the oven is turned on.

Procedure

To calibrate the screen, do the following.

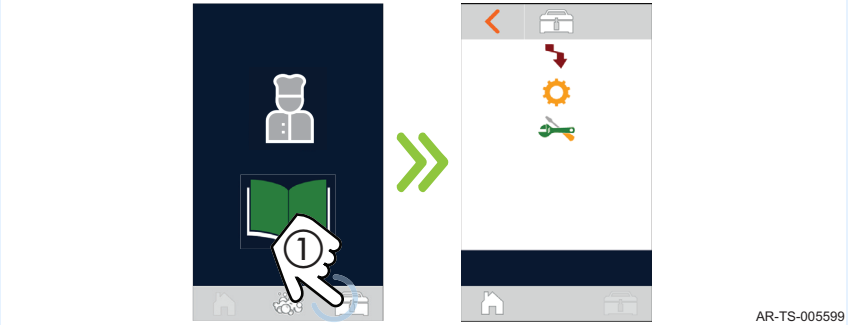
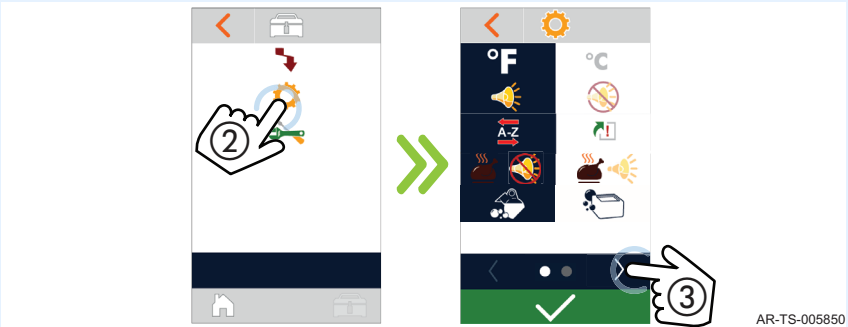
Step	Action
1.	<p>Touch the utilities icon ①. The utilities screen displays.</p>  <p style="text-align: right;">AR-TS-005599</p>
2.	<p>Touch the settings icon ②. The settings screen displays.</p> <p>Touch the arrow icon ③ to view the second settings screen.</p>  <p style="text-align: right;">AR-TS-005850</p>

Continued on next page

Continued from previous page

3. **Touch** the calibrate screen icon ④. The calibrate screen displays.

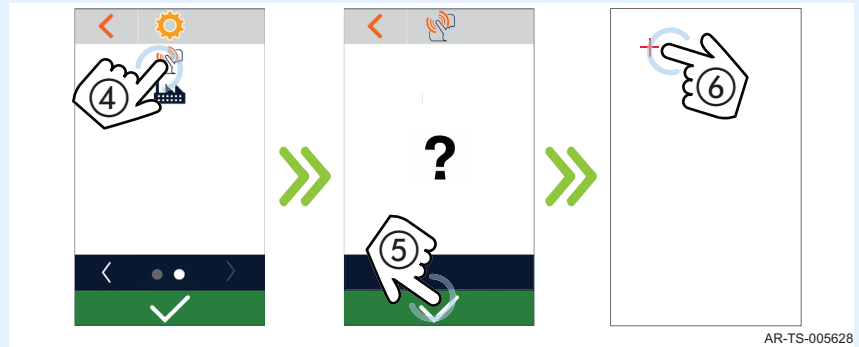

4. **Touch** the green check mark icon ⑤. The second calibrate screen displays.

5. **Touch** the plus sign icon ⑥ as it appears in each corner of the screen.

When all four corners have been touched, the start-up screen will appear briefly, then the display will return to the home screen.

Result

The screen has been calibrated.

How to Turn On and Turn Off the Holding Cabinet

Before you begin

The holding cabinet must be connected to electric power.

Turning on the holding cabinet

To turn on the holding cabinet, do the following.

Step	Action
------	--------

1. **Set** the power switch to the ON (I) position ①.

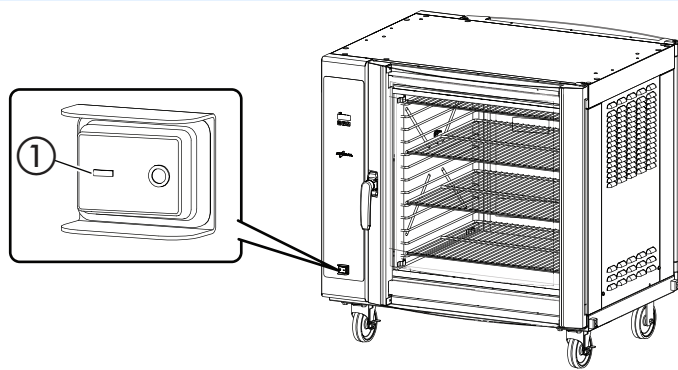

The holding cabinet is now on.

Turning off the holding cabinet

To turn off the holding cabinet, do the following.

Step	Action
------	--------

1. **Set** the power switch to the OFF (O) position.

The holding cabinet is now off.

How to Operate the Holding Cabinet

Before you begin

The holding cabinet must be connected to electric power and turned on.

Procedure

To operate the holding cabinet, do the following.

Step	Action
1.	Set the temperature using the arrow buttons ①.
<p>NOTE: The temperature set-point range is 60°F – 200°F (16°C – 93°C)</p>  <p>Press and hold the arrow button to change degree intervals by ten (10) degrees.</p>	
2.	Press and hold the temperature recall button ② to display the actual temperature.

1. **Set** the temperature using the arrow buttons ①.

NOTE: The temperature set-point range is 60°F – 200°F (16°C – 93°C)

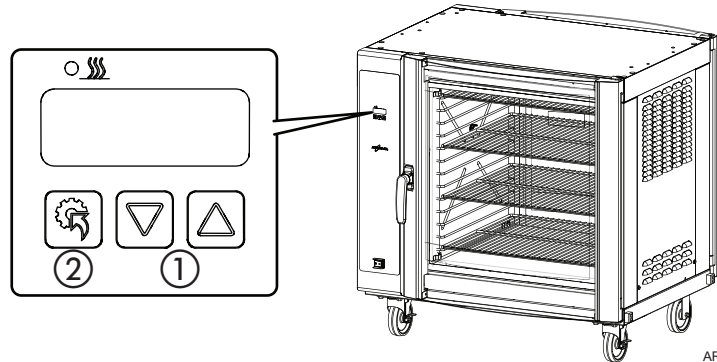

AR-TS-006164

Press and hold the arrow button to change degree intervals by ten (10) degrees.

Displaying the temperature

2. **Press and hold** the temperature recall button ② to display the actual temperature.

Result

The holding cabinet is now ready for holding food.

How to Select the Cleaning Method

Before you begin

Make sure the oven is turned on.

Procedure

To select the cleaning method, do the following.

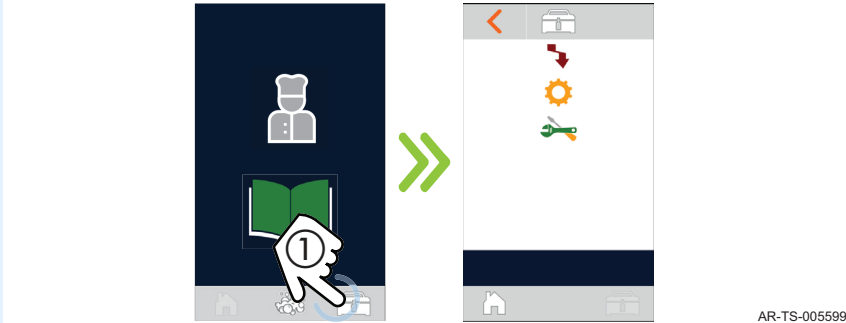
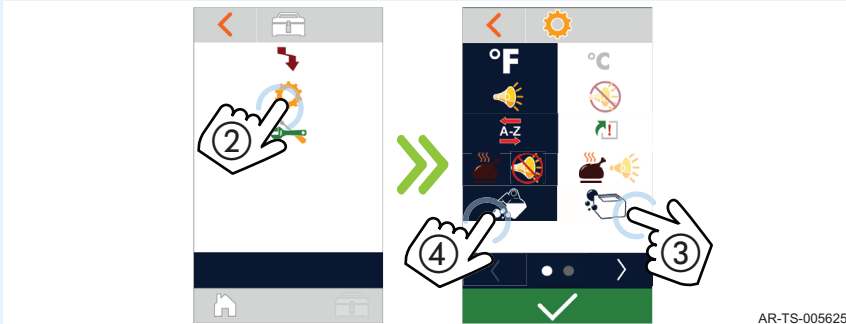
Step	Action
1.	<p>Touch the utilities icon ①. The utilities screen displays.</p>  <p style="text-align: right;">AR-TS-005599</p>
2.	<p>Touch the settings icon ②. The settings screen displays.</p> <p>Touch the tablet cleaner icon ③ to clean using tablet cleaner or the liquid cleaner icon ④ to clean using liquid cleaner.</p>  <p style="text-align: right;">AR-TS-005625</p>
3.	<p>Touch the green check mark icon.</p> <div style="border: 1px solid black; padding: 5px; margin-top: 10px;"> <p>NOTE: This will set the cleaning method. The oven will not start a cleaning sequence.</p> </div>

Result

The cleaning method has been selected.

How to Use the Service Screen

Before you begin

Make sure:

- The oven is turned on.
- The oven is idle and not currently in a cook or cleaning sequence.

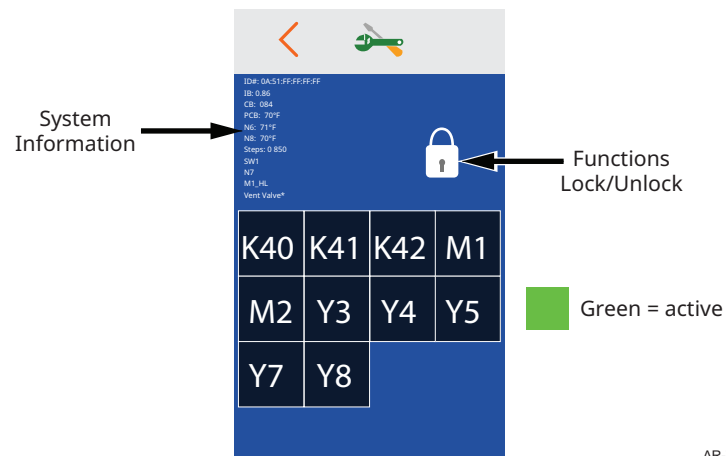

AR-TS-016434

Ref.	Description
K40	Browning heater elements
K41	Center heater element
K42	Wash water heater element
M1	Convection motor
M2	Spit motor
Y3	Water fill solenoid
Y4	Wash pump
Y5	Drain pump
Y7	Grease pump
Y8	Liquid soap pump

Continued on next page

Continued from previous page

Procedure

To navigate to the service screen, do the following.

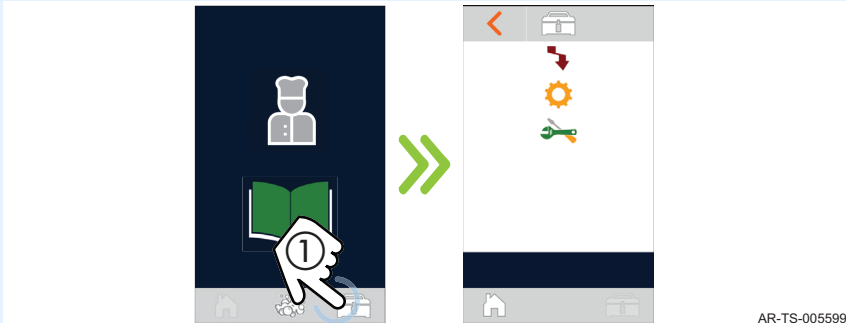
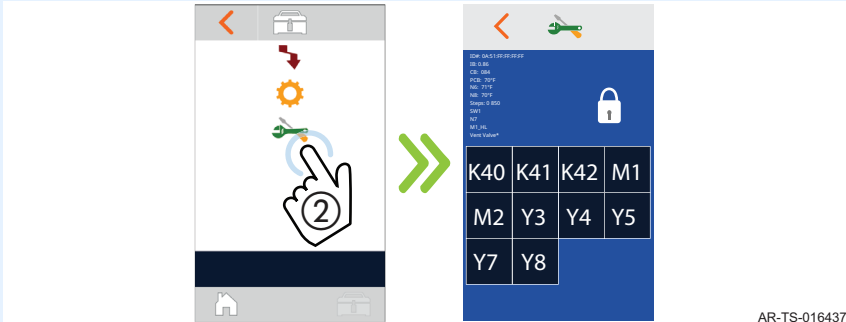
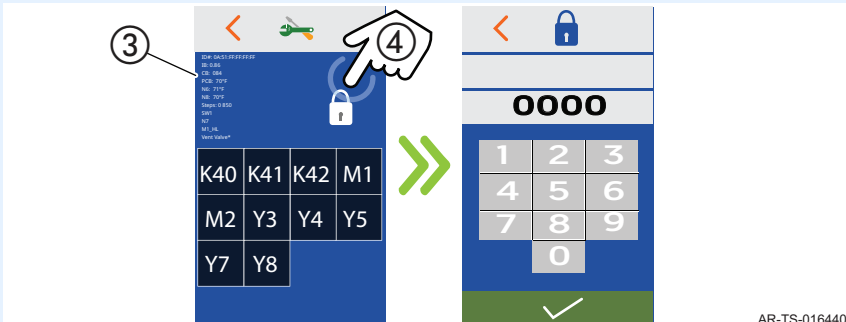
Step	Action
1.	<p>Touch the utilities icon ①. The utilities screen displays.</p>  <p style="text-align: right;">AR-TS-005599</p>
2.	<p>Touch the service icon ②. The service screen displays.</p>  <p style="text-align: right;">AR-TS-016437</p>
3.	<p>Software versions and temperatures are displayed ③.</p> <p>Touch the lock icon ④. The pass code screen displays.</p>  <p style="text-align: right;">AR-TS-016440</p>

Continued on next page

Continued from previous page

4. **Enter** the pass code 6702 and **touch** the check mark (5). The unlock icon will display.



AR-TS-016443

5. **Touch** the designation for the component to be tested. The box will turn green indicating the component is being energized.

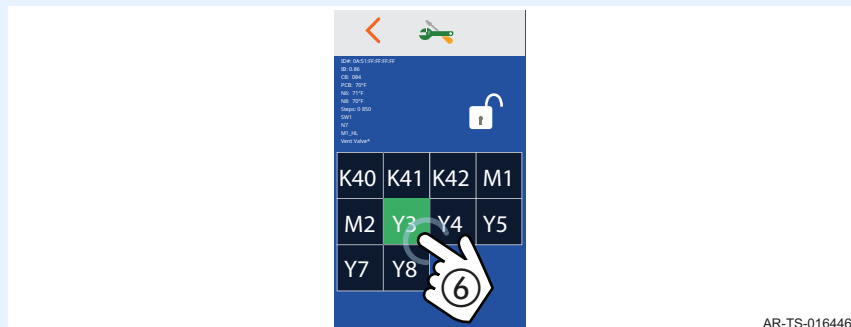

AR-TS-016446

6. **Touch** the return icon to exit the service screen.

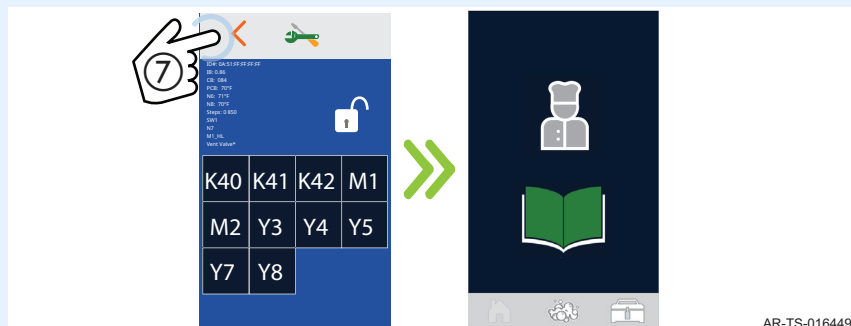

AR-TS-016449

Result

The procedure is complete.

This page is intentionally left blank.

Exterior Panels

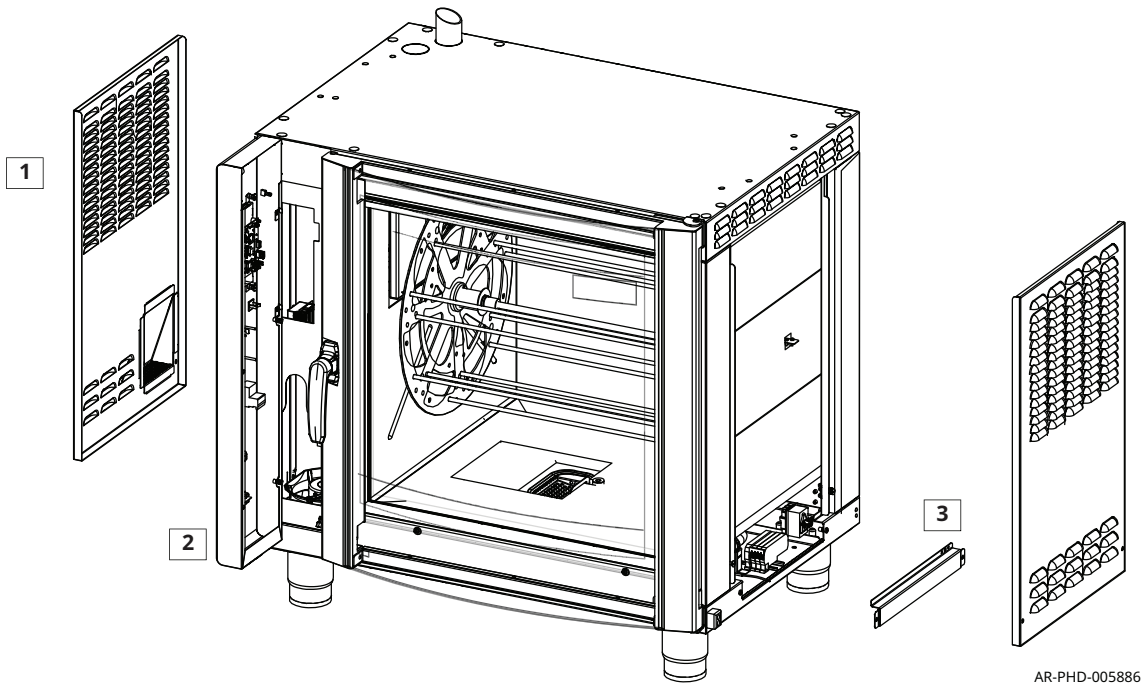

AR-PHD-005886

Ref.	Description
1	Left service panel, electrical chassis, heating elements, pumps, motors, N7 HI limit, cooling fans.
2	Control panel, interface board (IB), LCD display.
3	Right service panel, N6 cavity temperature sensor, water heater, N8 Thermistor, N9 HI limit.

Left Service Panel

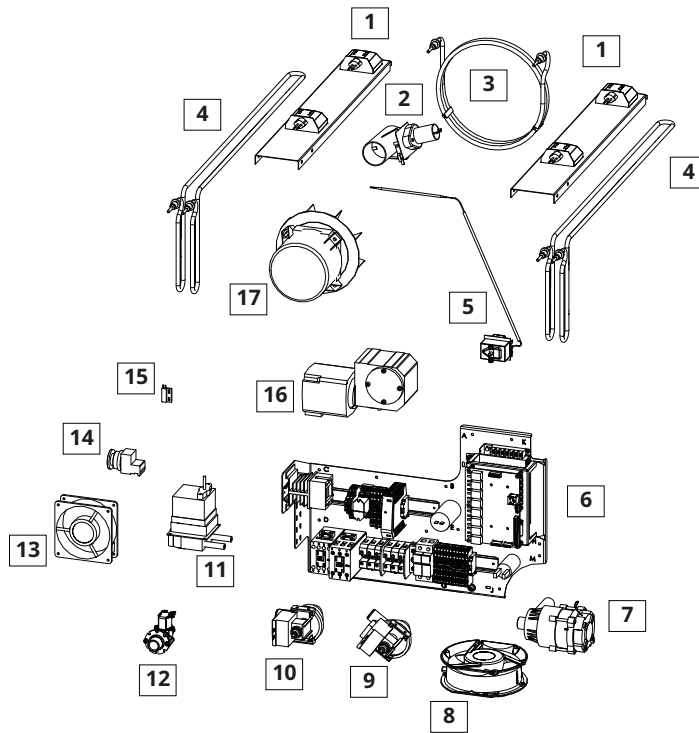

AR-PHD-005889

Ref.	Electrical Schematic Identifier	Description
1	LP1, LP2, LP3, LP4	Lights
2	Browning valve	Browning valve
3	R3	Convection heating element
4	R1, R2	Browning heating elements
5	N7	HI-limit switch
6	-	Electrical chassis
7	Y4	Wash pump
8	Cooling fan 1	Cooling fan
9	Y7	Grease pump
10	Y5	Drain pump
11	Y8	Liquid cleaner pump
12	Y3	Water solenoid
13	Cooling fan 2	Cooling fan
14	Jog button 2	Spit Jog button, pass through door
15	Door SW 2	Door switch, pass through door
16	M2	Spit motor
17	M1	Convection motor

Left Service Panel Components

Refer to graphic: AR-PHD-005889

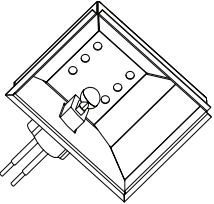
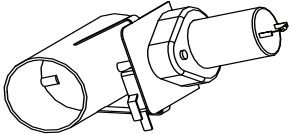
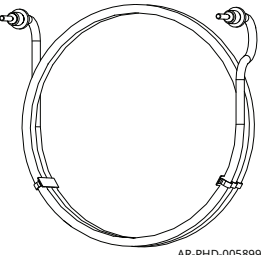
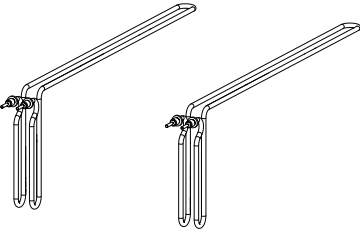
Ref	Component	Description
1	 <p>AR-PHD-005892</p>	LP1 LP2 LP3 LP4 Lights 12 VDC 20W
2	 <p>AR-PHD-005895</p>	Browning valve Motor 12 VDC Microswitch contacts closed when the valve is open.
3	 <p>AR-PHD-005899</p>	R3, Convection element, 208 volt, 15 amp, 14 ohms 240 volt, 13 amp, 18 ohms.
4	 <p>AR-PHD-005902</p>	R1, R2 Browning elements 208 volt, 15 amp, 14 ohms 240 volt, 13 amp, 18 ohms

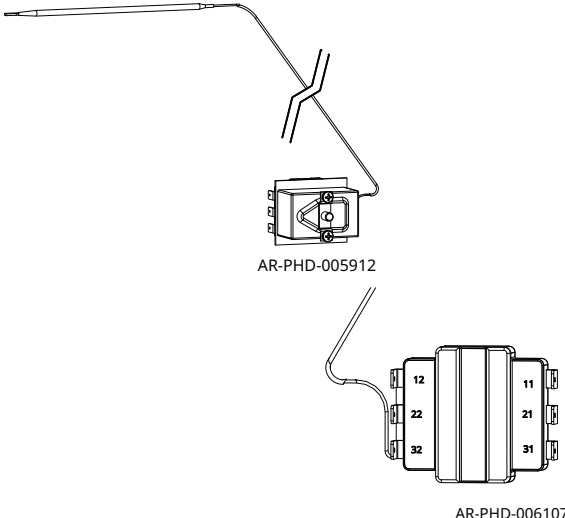
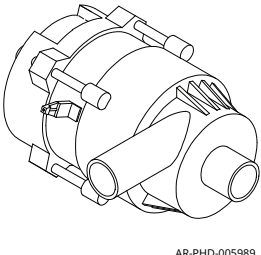
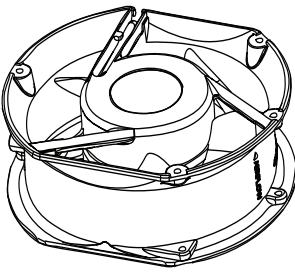
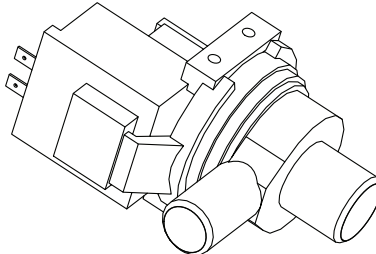
Ref	Component	Description
5	 <p>The diagram shows a long, thin probe with a hook-like end, connected to a small rectangular control box labeled AR-PHD-005912. This box is connected to a larger rectangular terminal block labeled AR-PHD-006107. The terminal block has six terminals on its front face, labeled 11, 12, 21, 22, 31, and 32.</p>	<p>N7 HI-Limit switch 527°F / 275°C Manual reset</p>
7	 <p>The diagram shows a cylindrical pump assembly with various ports and a mounting bracket. It is labeled AR-PHD-005989.</p>	<p>Y4 Wash pump</p>
8	 <p>The diagram shows a circular cooling fan assembly with a central hub and multiple blades. It is labeled AR-PHD-005989.</p>	<p>Cooling Fan 1</p>
9	 <p>The diagram shows a complex pump assembly with a motor housing and a large outlet pipe. It is labeled AR-PHD-005992.</p>	<p>Y7 Grease pump Thermal protected 135° C / 275° F same P/N as the drain pump</p>

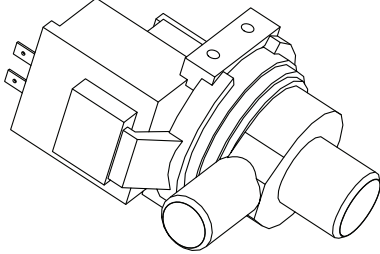
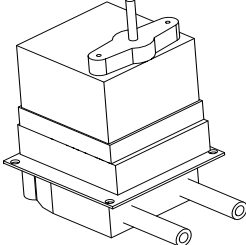
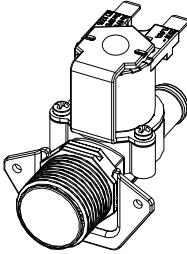
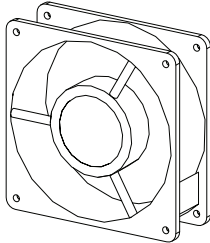
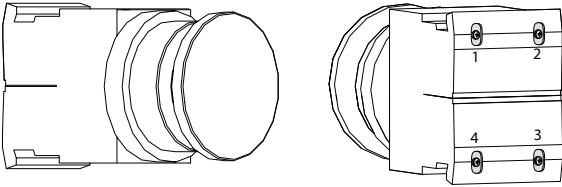
Ref	Component	Description
10	 <p style="text-align: center;">AR-PHD-005992</p>	<p>Y5 Drain pump</p> <p>Thermal protected 135° C / 275° F same part number as the grease pump</p>
11	 <p style="text-align: center;">AR-PHD-006001</p>	<p>Y8 Liquid cleaner pump</p>
12	 <p style="text-align: center;">AR-PHD-006004</p>	<p>Y3 Water solenoid</p> <p>Coil resistance 4K Ohms</p>
13	 <p style="text-align: center;">AR-PHD-006010</p>	<p>Cooling fan 2</p>
14	 <p style="text-align: center;">AR-PHD-006013</p> <p style="text-align: center;">AR-PHD-006016</p>	<p>Jog button 2</p> <p>Pushbutton, momentary contact</p>

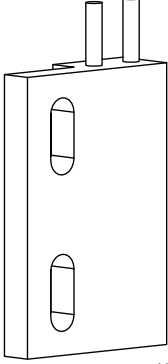
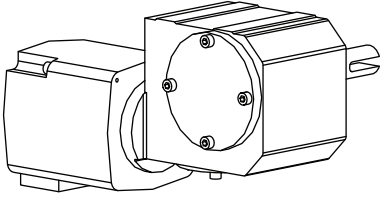
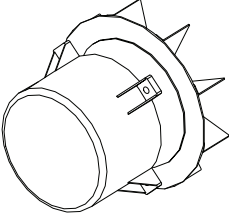
Ref	Component	Description
15	 <p data-bbox="565 653 686 674">AR-PHD-006019</p>	<p data-bbox="878 285 1027 310">Door switch</p> <p data-bbox="878 338 1227 363">SPST-NO, magnetic reed switch</p>
16	 <p data-bbox="618 932 740 953">AR-PHD-006022</p>	<p data-bbox="878 716 1057 741">M2 Spit motor</p> <p data-bbox="878 768 1143 793">Permanently lubricated</p>
17	 <p data-bbox="566 1247 646 1266">AR-PHD-006025</p>	<p data-bbox="878 999 1149 1024">M1 Convection motor</p>

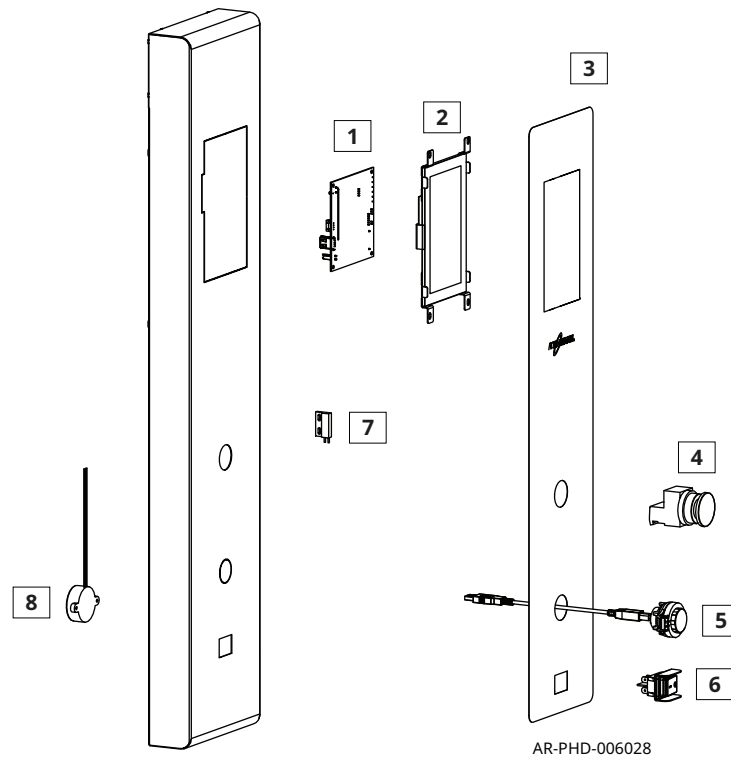

Control Panel



Ref.	Electrical Schematic Identifier	Description
1	Interface board	User interface board
2	-	Liquid Crystal Display (LCD)
3	-	Touch overlay
4	Jog button 1	Spit jog button, front door
5	-	USB port
6	On/Off switch	ON/OFF switch
7	Door SW 1	Door switch
8	Beeper assembly	Beeper

Control Panel Components

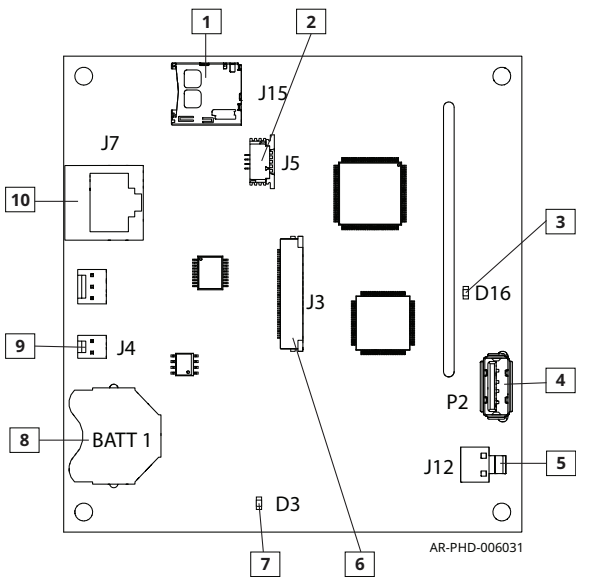
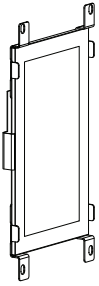
Refer to graphic: AR-PHD-006193

Ref	Component	Description
1		<p>User Interface Board</p> <ul style="list-style-type: none"> 1 J15 4 GB Micro SD card 2 J5 Ribbon cable - touch overlay 3 D16 Light emitting diode, flashing, software running ok 4 P2 USB connector 5 J12 DC Voltage supply 6 J3 Ribbon cable - LCD display 7 D3 Light emitting diode, solid - control board voltage ok 8 BATT 1 Real time clock battery 9 J4 Beeper 10 J7 RS-485 communication with the control board
2		<p>Liquid Crystal Display (LCD)</p>
3		<p>Touch overlay</p>

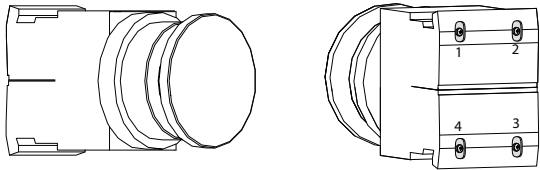
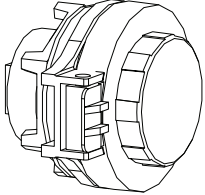
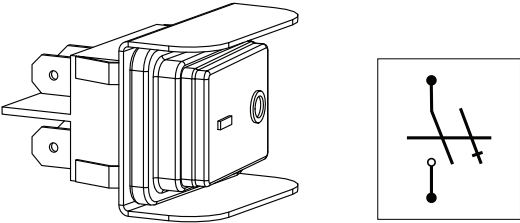
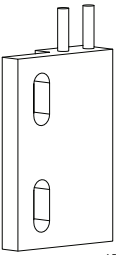
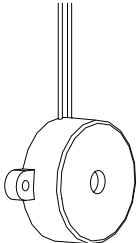
Ref	Component	Description
4	 <p>AR-PHD-006013 AR-PHD-006016</p>	<p>Jog button 1 Pushbutton, momentary contact</p>
5	 <p>AR-PHD-006040</p>	<p>USB Port</p>
6	 <p>AR-PHD-006043 AR-PHD-006046</p>	<p>ON/OFF Switch Rocker switch, double pole</p>
7	 <p>AR-PHD-006019</p>	<p>Door switch 1 SPST-NO, magnetic reed switch</p>
9	 <p>AR-PHD-006052</p>	<p>Beeper</p>

Right Service Panel

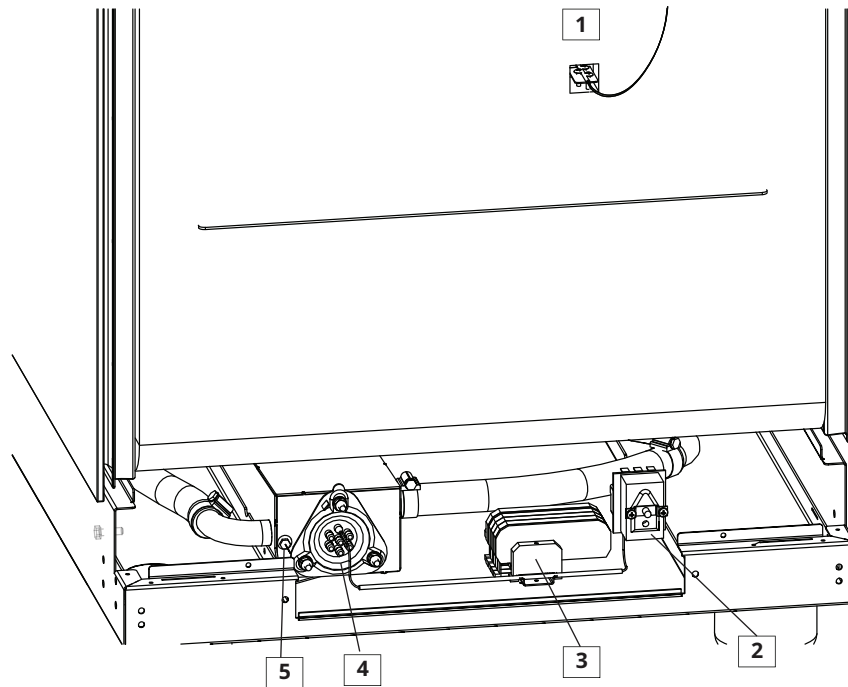

AR-PHD-006058

Ref.	Electrical Schematic Identifier	Description
1	N6	100 Ohm RTD cavity temperature sensor
2	N9	Water heater HI limit
3	-	Terminal blocks
4	R4	Water heater elements
5	N8	J-Type thermistor

Electrical Chassis — 208-240 volt, 1 phase

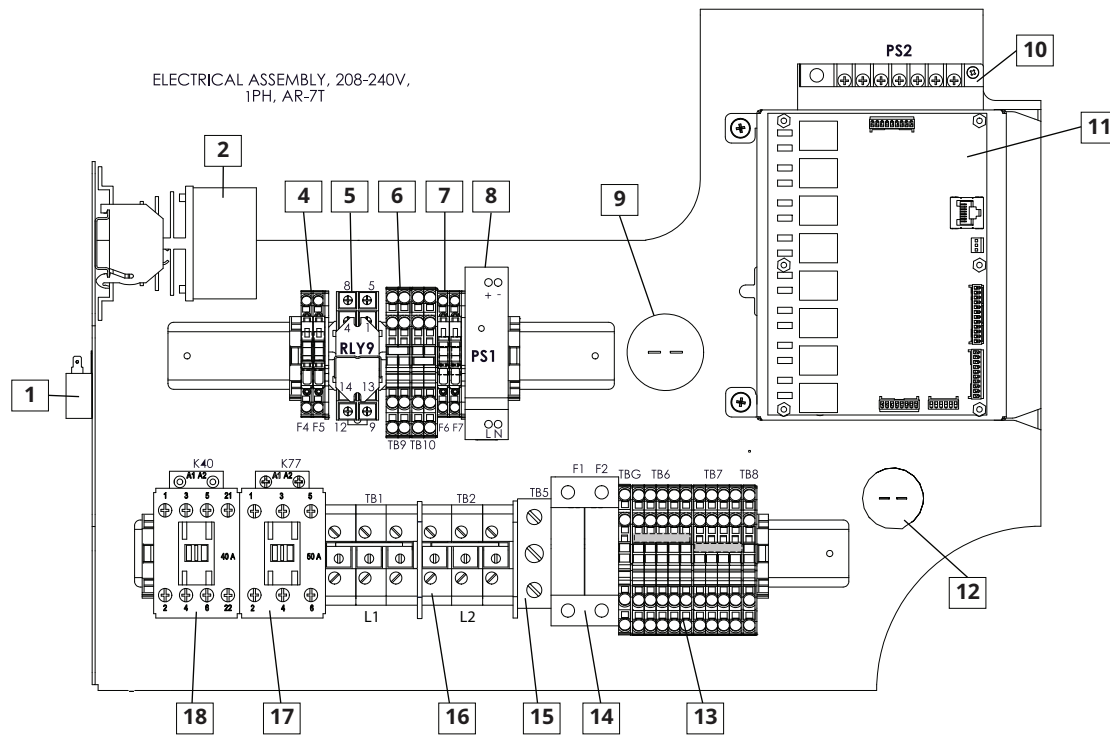

AR-PHD-005915

Ref.	Electrical Schematic Identifier	Description
1	C1	Capacitor, spit motor
2	SSR	Solid state relay
3	-	-
4	F4, F5	Fuses, lights
5	RLY 9	Relay, browning valve
6	TB 9, TB 10	Terminal blocks, DC voltage output from PS1
7	F6, F7	Fuses, DC voltage output from PS1
8	PS1	DC power supply 1
9	C2	Capacitor, convection motor
10	PS2	DC power supply 2
11	Control board	Control board (CB)
12	C3	Capacitor, wash pump
13	TBG, TB6, TB7, TB8	Terminal blocks
14	F1, F2	Fuses, line voltage
15	TB5	Terminal block, electrical supply ground connection
16	TB1, TB2	Terminal blocks, electrical supply line connections
17	K-77	Safety contactor
18	K-40	Heat contactor

Electrical Chassis — 208-240 volt, 3 phase

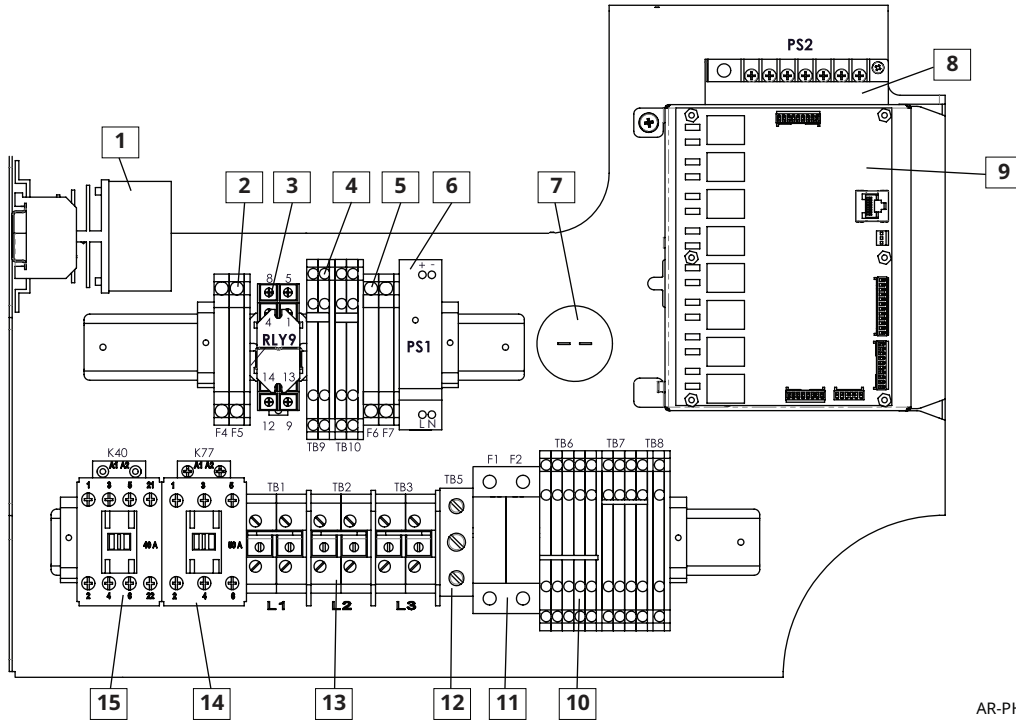

AR-PHD-005918

Ref.	Electrical Schematic Identifier	Description
1	SSR	Solid state relay
2	F4, F5	Fuses, lights
3	RLY 9	Relay, browning valve
4	TB 9, TB 10	Terminal blocks, DC voltage output from PS1
5	F6, F7	Fuses, DC voltage output from PS1
6	PS1	DC power supply 1
7	C2	Capacitor, convection motor
8	PS2	DC power supply 2
9	Control board	Control board (CB)
10	TB6, TB7, TB8	Terminal blocks
11	F1, F2	Fuses, line voltage
12	TB5	Terminal block, electrical supply ground connection
13	TB1, TB2, TB3	Terminal blocks, electrical supply line connections
14	K-77	Safety contactor
15	K-40	Heat contactor

Electrical Chassis — 380-415 volt, 3 phase

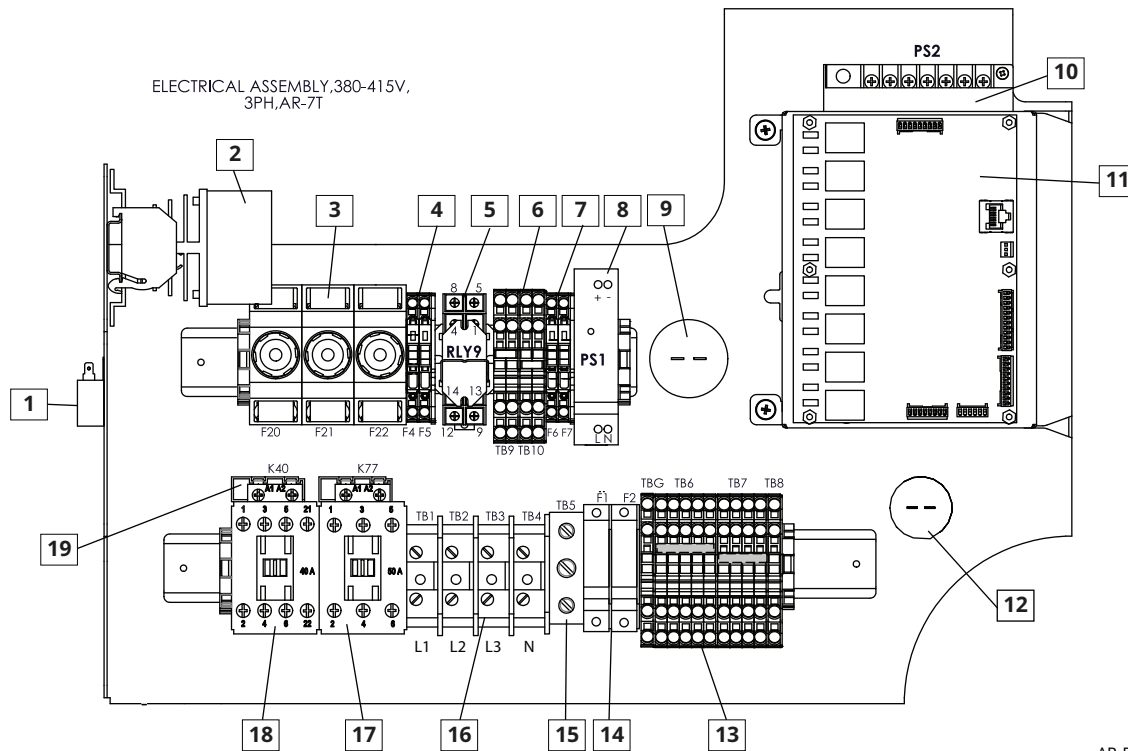

AR-PHD-005923

Ref.	Electrical Schematic Identifier	Description
1	C1	Capacitor, spit motor
2	SSR	Solid state relay
3	F20, F21, F22	Fuses, heating elements (CE only)
4	F4, F5	Fuses, lights
5	RLY 9	Relay, browning valve
6	TB 9, TB 10	Terminal blocks, DC voltage output from PS1
7	F6, F7	Fuses, DC voltage output from PS1
8	PS1	DC power supply 1
9	C2	Capacitor, convection motor
10	PS2	DC power supply 2
11	Control board	Control board (CB)
12	C3	Capacitor, wash pump
13	TBG, TB6, TB7, TB8	Terminal blocks
14	F1, F2	Fuses, line voltage
15	TB5	Terminal block, electrical supply ground connection
16	TB1, TB2, TB3, TB4	Terminal blocks, electrical supply line connections
17	K-77	Safety contactor
18	K-40	Heat contactor
19	FI-33990	Filters (CE only)

Electrical Chassis Components

Refer to graphic: AR-PHD-006211

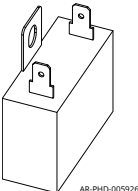
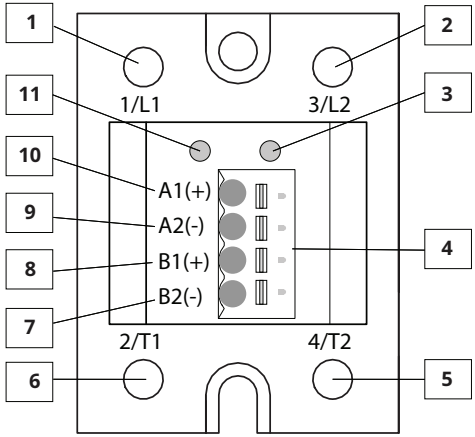
Ref	Component	Description																																	
1	 <p style="text-align: center; font-size: small;">AR-PHD-005926</p>	C1 Capacitor																																	
2	 <p style="text-align: center; font-size: small;">AR-PHD-005929</p>	<p>K41, K42, SSR Solid State Relay</p> <p>Dual circuit</p> <table border="0"> <tr> <td style="padding-right: 10px;">1</td> <td style="padding-right: 10px;">L1</td> <td>Terminal 1/L1 – circuit A</td> </tr> <tr> <td>2</td> <td>L2</td> <td>Terminal 3/L2 – circuit B</td> </tr> <tr> <td>3</td> <td>-</td> <td>Circuit B call for heat indicator</td> </tr> <tr> <td>4</td> <td>-</td> <td>Push to insert / release a wire</td> </tr> <tr> <td>5</td> <td>T2</td> <td>Terminal 4/T2 – circuit B</td> </tr> <tr> <td>6</td> <td>T1</td> <td>Terminal 2/T1 – circuit A</td> </tr> <tr> <td>7</td> <td>B2 (-)</td> <td>Circuit B DC – from control board</td> </tr> <tr> <td>8</td> <td>B1 (+)</td> <td>Circuit B DC + from control board</td> </tr> <tr> <td>9</td> <td>A2 (-)</td> <td>Circuit A DC – from control board</td> </tr> <tr> <td>10</td> <td>A1 (+)</td> <td>Circuit A DC + from controlboard</td> </tr> <tr> <td>11</td> <td>-</td> <td>Circuit A call for heat indicator</td> </tr> </table>	1	L1	Terminal 1/L1 – circuit A	2	L2	Terminal 3/L2 – circuit B	3	-	Circuit B call for heat indicator	4	-	Push to insert / release a wire	5	T2	Terminal 4/T2 – circuit B	6	T1	Terminal 2/T1 – circuit A	7	B2 (-)	Circuit B DC – from control board	8	B1 (+)	Circuit B DC + from control board	9	A2 (-)	Circuit A DC – from control board	10	A1 (+)	Circuit A DC + from controlboard	11	-	Circuit A call for heat indicator
1	L1	Terminal 1/L1 – circuit A																																	
2	L2	Terminal 3/L2 – circuit B																																	
3	-	Circuit B call for heat indicator																																	
4	-	Push to insert / release a wire																																	
5	T2	Terminal 4/T2 – circuit B																																	
6	T1	Terminal 2/T1 – circuit A																																	
7	B2 (-)	Circuit B DC – from control board																																	
8	B1 (+)	Circuit B DC + from control board																																	
9	A2 (-)	Circuit A DC – from control board																																	
10	A1 (+)	Circuit A DC + from controlboard																																	
11	-	Circuit A call for heat indicator																																	

Ref	Component	Description
	<p>208-240 V, 1 PH AR-PHD-005932</p> <p>208-240 V, 3 PH AR-PHD-006111</p> <p>380-415 V, 3 PH AR-PHD-006114</p>	<p>SSR Circuits, energized</p>
<p>3</p>	<p>AR-PHD-005935</p>	<p>F20, F21, F22 Fuses Heater elements (CE Only)</p>

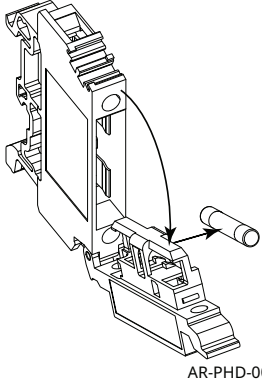
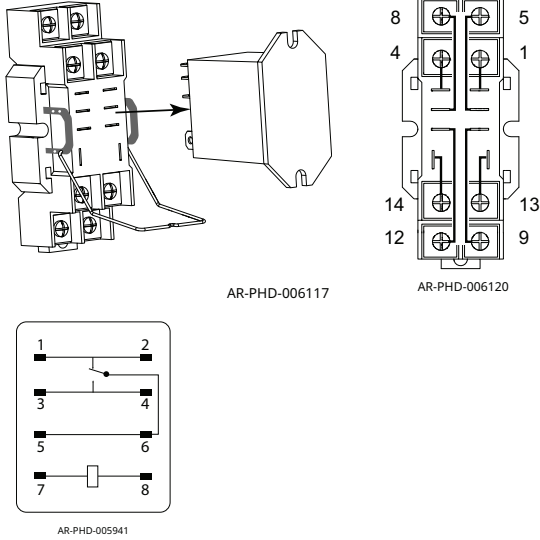
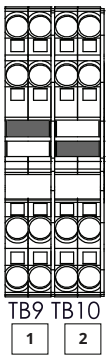
Ref	Component	Description
4	 <p style="text-align: center;">AR-PHD-005938</p>	<p>F4, F5 Fuses</p> <p>Lights</p>
5	 <p style="text-align: center;">AR-PHD-006117</p> <p style="text-align: center;">AR-PHD-006120</p> <p style="text-align: center;">AR-PHD-005941</p>	<p>RLY9 Relay</p> <p>Browning valve 12 VDC coil</p>
6	 <p style="text-align: center;">TB9 TB10</p> <p style="text-align: center;">1 2</p> <p style="text-align: center;">AR-PHD-005944</p>	<p>TB 9 TB 10 Terminal blocks</p> <p>1 12 VDC + voltage from PS 1</p> <p>2 12 VDC - voltage from PS 1</p>

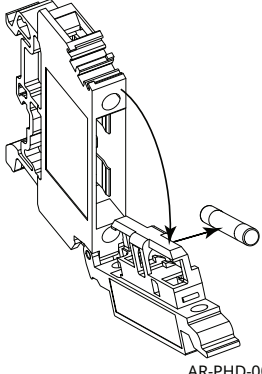
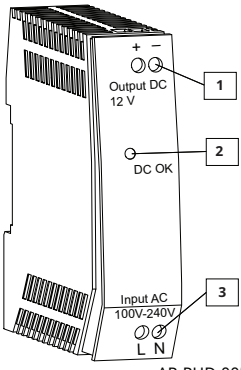
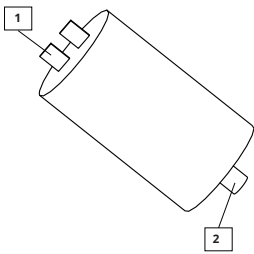
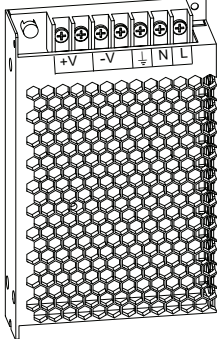
Ref	Component	Description
7	 <p style="text-align: center;">AR-PHD-005938</p>	<p>F6 F7 Fuses</p> <p>DC voltage from PS1</p>
8	 <p style="text-align: center;">AR-PHD-005947</p>	<p>PS1 12 VDC Power supply</p> <p>1 12 VDC output</p> <p>2 DC OK indicator light</p> <p>3 100–240 VAC Input</p>
9	 <p style="text-align: center;">AR-PHD-005950</p>	<p>C2, Capacitor, convection motor</p> <p>16μF</p> <p>1 0.250 inch spade terminals</p> <p>2 M8 mounting stud</p>
10	 <p style="text-align: center;">AR-PHD-005953</p>	<p>PS2, 12 VDC Power supply</p>

Ref	Component	Description
11	<p>AR-PHD-005956</p>	<p>CB, Control Board</p> <p>1 J2 12 VDC supply and personality jumper</p> <p>2 D12 Light emitting diode, solid - control board voltage ok</p> <p>3 D11 Light emitting diode, flashing - software running ok</p> <p>4 J12 RS-485 communication with the interface board</p> <p>5 J11 Outputs to the SSR</p> <p>6 J9 Inputs door switches, HI limits, and browning valve</p> <p>7 J10 Water heater J-type thermistor</p> <p>8 J4 100 ohm RTD temperature sensor</p> <p>9 D1-D8 Light emitting diodes — signal to energize the relay</p> <p>10 RY8 Y8 Liquid cleaner pump relay</p> <p>11 RY7 Y7 Grease pump relay</p> <p>12 RY6 Y5 Drain pump relay</p> <p>13 RY5 Y4 Wash pump relay</p> <p>14 RY4 Y3 Water solenoid Relay</p> <p>15 RY3 M2 M2 spit motor relay</p> <p>16 RY2 M1 M1 convection motor relay</p> <p>17 RY1 K40 K40 heat contactor relay</p>
12	<p>AR-PHD-005959</p>	<p>C3 Capacitor</p> <p>2μF</p>

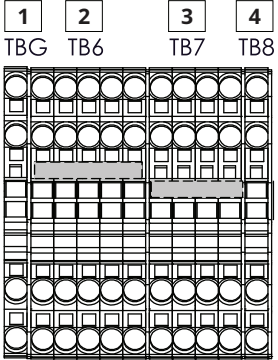
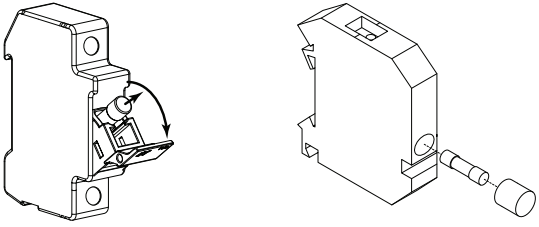
Ref	Component	Description
13	 <p style="text-align: center;">AR-PHD-005962</p>	<p>TBG TB6 TB7 TB8 Terminal Blocks</p> <p>1 TBG Ground</p> <p>2 D6 L1 voltage after the On/Off switch</p> <p>3 D7 L2/N after F2</p> <p>4 D8 Jog button, split motor</p>
14	 <p style="text-align: center;">AR-PHD-005965 AR-PHD-005968</p>	<p>F1, F2 Fuses</p>

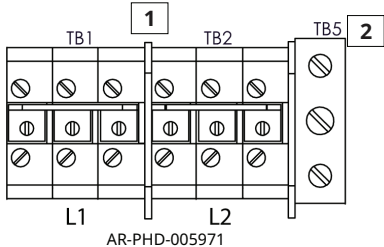
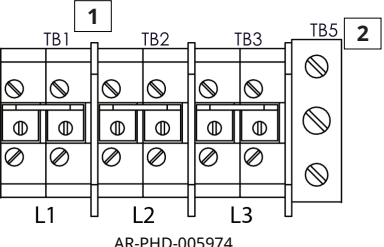
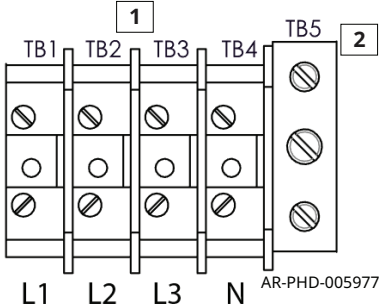
Ref	Component	Description
	<p>208-240 volt, 1 phase</p>  <p>AR-PHD-005971</p>	<p>TB1, TB2, TB3, TB4, TB5, Terminal blocks</p> <p>1 electrical supply line connections</p> <p>2 electrical supply ground connection</p>
15	<p>208-240 volt, 3 phase</p>  <p>AR-PHD-005974</p>	
	<p>380-415 volt, 3 phase</p>  <p>AR-PHD-005977</p>	

Ref	Component	Description
<p>16</p>		<p>K40, K77, EMI Filters</p> <ul style="list-style-type: none"> 1 FI-33990 Contactor 2 FI-33990 Safety contactor 3 FI-33990 Electromagnetic interference (EMI) Filter (CE only)

This page is intentionally left blank.

Maintenance Schedule

Requirements

- Make sure the oven is under 140°F (60°C) before cleaning.
- Do not use a hose or water jet on external and technical parts of the appliance.

Daily

For daily maintenance, do the following.

- **Clean** all grease and debris from the bottom of the oven. Do not wipe debris into the drain.
- **Clean** the drip tray.
- **Clean** the glass and outside of the oven.
- **Clean** the door gasket.
- **Remove** debris from the drain screen.
- **Run** automatic cleaning cycle.
- **Empty** the grease collection container, if needed.

Weekly

For weekly maintenance, do the following.

- **Inspect** the door gaskets for tears.
- **Clean** the outside of the oven with a stainless steel cleaner.
- **Inspect** grease collection hoses and containers for damage.
- **Make sure** all lights are working.
- **Inspect** the oven for grease or carbon buildup.
- **Inspect** the oven for scale buildup.
- **Inspect** the oven cavity exhaust port and vent pipe.
 - **Clean** out any grease or carbon buildup
 - **Inspect** the gasket around the vent pipe. Replace as needed

Monthly

For monthly maintenance, do the following.

- **Descale** the oven using Alto-Shaam's ScaleFree descaling powder.
- **Inspect** the drain piping for leaks.
- **Clean** the convection fan box.
- **Inspect** the touchscreen for damage.

Continued on next page

Continued from previous page

Yearly

For yearly maintenance, do the following.



NOTE: Must be performed by a qualified professional.

- **Inspect** the humidity valve hoses and tubes
 - **Clean** any grease or carbon buildup.
 - **Replace** hoses as needed.
- Clean the Vent Pipe from the top of the unit.

How to Clean the Oven Using Liquid Cleaner

Before you begin



WARNING: Burn hazard.

Wear protective gloves, protective clothing, eye protection, and face protection when handling oven cleaner. Do not open the oven door during the wash or rinse cycle.

NOTICE

Do not use steel pads, wire brushes, or scrapers when cleaning.

Make sure:

- The liquid cleaner is installed. See topic *How to Install the Liquid Cleaner*.
- You have set the cleaning method to liquid cleaning. See topic *How to Select the Cleaning Method*.
- You have enough liquid cleaner (CE-36457) to clean the oven.

Procedure

To clean the oven using liquid cleaner, do the following.

Step	Action
1.	Make sure the oven is cool—oven is less than 140°F (60°C).
2.	Remove food debris, solid wastes, poultry skin and bones from the drain screen.

Continued on next page

Continued from previous page

3. **Touch** the cleaning icon ①. The cleaning screen display.

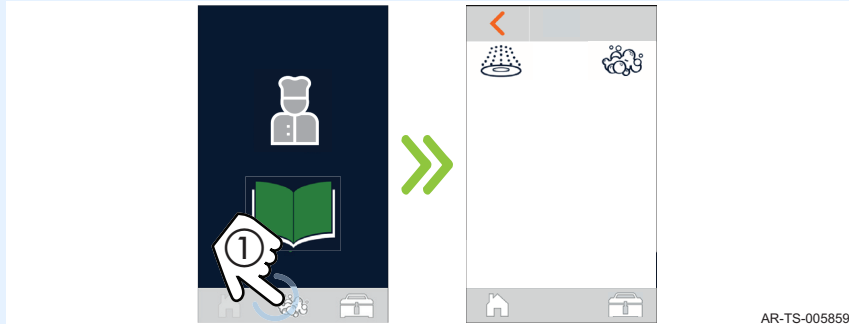

AR-TS-005859

4. **Touch** the wash icon ②. The wash screen displays.
Touch the green check mark icon ③ to begin the wash cycle.

NOTE: The wash cycle takes approximately 2-3 minutes to heat the water before the water begins to spray.

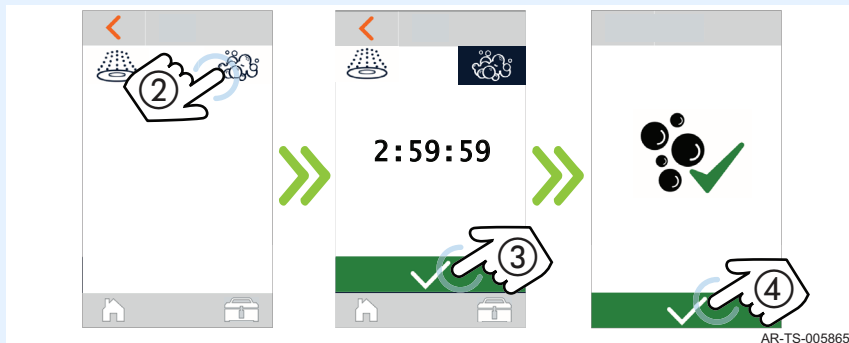

AR-TS-005865

The wash cycle takes 2:59:59 to complete. At the end of the wash cycle, the oven sounds an alert and the wash cycle complete screen displays.

5. **Touch** the green check mark icon ④ to return to the home screen when the wash cycle is complete.

Result

The oven has completed a wash cycle using liquid cleaner.

How to Clean the Oven Using Tablets

Before you begin



WARNING: Burn hazard.

Wear protective gloves, protective clothing, eye protection, and face protection when handling oven cleaner. Do not open the oven door during the wash or rinse cycle.

NOTICE

Do not use steel pads, wire brushes, or scrapers when cleaning.

Make sure:

- You have set the cleaning method to tablet cleaning. See topic *How to Select the Cleaning Method*.
- You have enough concentrated cleaning tablets (CE-46991) to clean the oven.

Procedure

To clean the oven using concentrated cleaning tablets, do the following.

Step	Action
1.	Make sure the oven is cool—oven is less than 140°F (60°C).
2.	Remove food debris, solid wastes, poultry skin and bones from the drain screen.

Continued on next page

Continued from previous page

3. **Insert** two (2) concentrated cleaning tablets into the cavity drain ①. **Make sure** the drain screen is closed before starting the wash cycle.

NOTICE Do not place the cleaning tablets on the top of the drain or the bottom of the oven. The tablets could damage the interior of the oven.

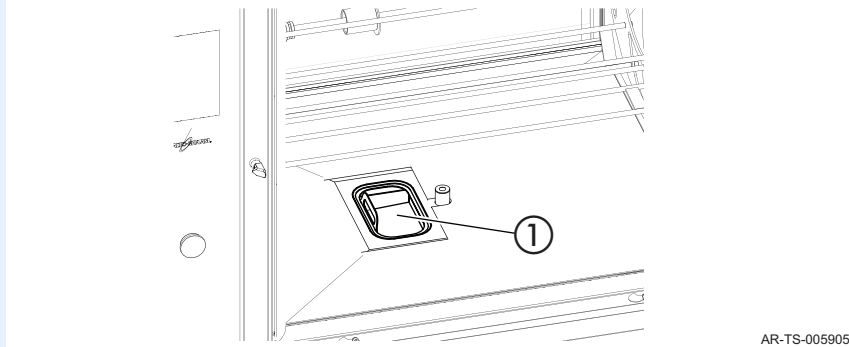

4. **Touch** the cleaning icon ②. The cleaning screen display.



Continued on next page

Continued from previous page

5. **Touch** the wash icon ③. The wash screen displays.
Touch the green check mark icon ④ to begin the wash cycle.

NOTE: The wash cycle takes approximately 2-3 minutes to heat the water before the water begins to spray.

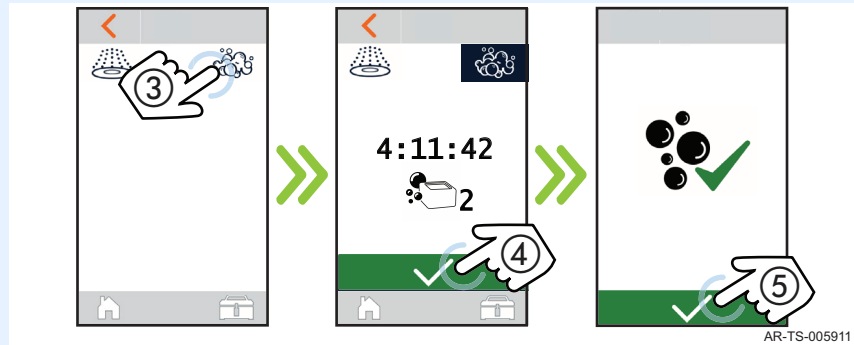

The wash cycle takes 4:11:42 to complete. At the end of the wash cycle, the oven sounds an alert and the wash cycle complete screen displays.

6. **Touch** the green check mark icon ⑤ to return to the home screen when the wash cycle is complete.

Result

The oven has completed a wash cycle using tablets.

How to Clean and Inspect the Humidity Valve

Before you begin



WARNING: Burn hazard.

Wear protective gloves, protective clothing, eye protection, and face protection when handling oven cleaner. Do not open the oven door during the wash or rinse cycle.

NOTICE

Do not use steel pads, wire brushes, or scrapers when cleaning.



NOTE: Use the same procedure on either individual or stacked AR-7T ovens.

Procedure

To clean the humidity valve, do the following.

Step	Action
1.	Make sure the oven is cool—oven is less than 140°F (60°C).
2.	Clean the oven with a full wash cycle. See topics <i>How to Clean the Oven Using Liquid Cleaner</i> or <i>How to Clean the Oven Using Tablets</i> .
3.	Set the ON/OFF power switch to the OFF position, or disconnect the oven from power.
4.	Remove the humidity valve panel located on the right side of the oven.
5.	Check the humidity valve for debris buildup. Wipe out debris in the humidity valve with a kitchen towel if necessary.

Continued on next page

Continued from previous page

How to Inspect the Humidity Panel

6. **Remove** the screws on the side panel of the oven.

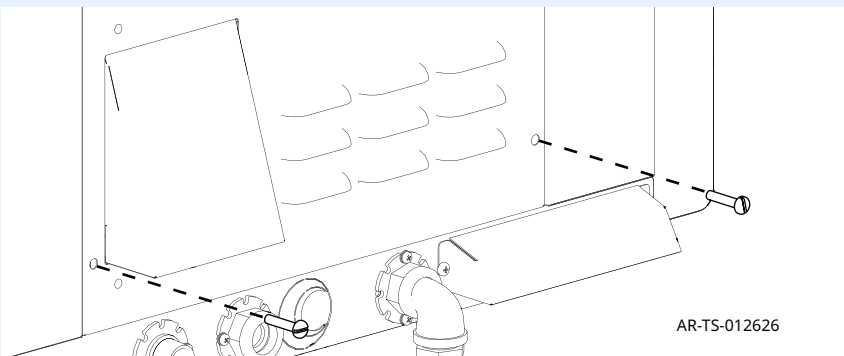

7. **Remove** the side panel.

8. **Check** parts around the humidity valve.
Ensure the humidity valve is not warped.
Inspect the clamps for proper tightness.
Examine the hoses for damage.

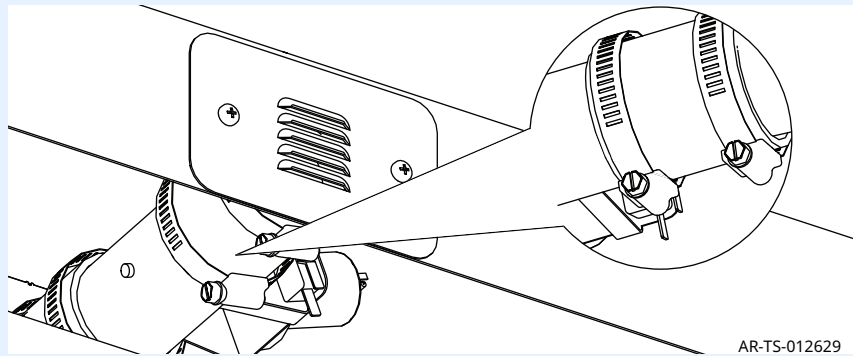

9. **Re-install** the side panel.

10. **Re-install** the humidity valve panel.

Result

The humidity valve is now clean.

This page is intentionally left blank.

AR-7T Error Codes

Code	Description	Possible Cause
PROG	Fatal error, call service.	Programmer error.
EADC	ADC is out of range.	Microprocessor on the control board (CB) may be failing. May have cold solder joint on the CB.
E-BC	Bootloader Chip is bad. Software updates cannot be performed.	Chip may have cold solder joint or other electrical distress.
E-CB	Control board and interface board software do not match. Update the software.	Control board or Interface board version is not current.
E-B0	PCB temperature sensor is short-circuited.	Board failure.
E-B1	PCB temperature sensor is open-circuit.	Board failure.
E-B2	PCB is over-temperature of 70°C.	Possible cooling fan failure in the control area. Possible runaway heater. Possible that we are too close to another piece of equipment or have inadequate ventilation.
E-I0	Short circuit in-line water heater sensor.	Sensor wires damaged.
E-I1	Open circuit in-line water heater sensor.	Sensor wires damaged.
E-I2	Water heater sensor over temperature	Sensor above 200°F (93.3°C).
E-SD	SD card is not detected.	SD card slot is bad. SD card is not present.
E-10	N6 cavity sensor is short-circuit.	Error at sensor input. Wrong RTD type (100Ω vs. 1000Ω). Check wiring. Board may be bad at sensor input.
E-11	N6 cavity sensor is open-circuit.	Error at sensor input. Wrong RTD type (100Ω vs. 1000Ω). Check wiring. Board may be bad at sensor input.
E-30	Temperature is 25°F below the target set point for more than 90 minutes.	Troubleshoot cavity heating element.
E-31	N6 cavity sensor over temperature, > 500°F for two consecutive minutes. If temperature exceeds 525°F, the program will stop.	If the oven has experienced an over temperature condition allow the oven to cool down for a minimum of 30 minutes. Press the high limit reset button. Resume cooking operation. If error reappears contact service provider.
E-41	Touch driver is detected, but not responding to queries.	Touch chip error on board.
E-43	Touch driver is missing.	Touch chip error on board.
E-44	Touch driver is detected, but not responding to queries.	Touch chip error on board.

Code	Description	Possible Cause
E-53	Motor high-limit is open.	Motor is too hot, and high-limit is legitimately open. Wiring to motor is incorrect. Board issues reading motor high-limit input switch.
E-55	Vent valve error, contact service.	Vent valve malfunction.
E-60	Real time clock checksum fail/invalid.	Date/Time reset to default value. Reset date/time to current.
E-61	Real time clock not responding/not detected/not present.	Control failure. Replace the control.
E-64	Real time clock not ticking.	Control failure. Replace the control.
E-66	Control board reset but interface board did not.	Electrical noise.
E-70	Personality wiring is incorrect, does not equate to a supported configuration.	Personality wiring is incorrect. Broken wire. Board issues reading personality jumpers. Old software with new configuration.
E-71	Control ID is not what is expected. The control board and interface board can talk, but are meant for different controls, a CB or IB update is required.	Control board is programmed for a different software than what is intended. Example: Rotisserie is plugged into a Cook and Hold or QuickChiller control board.
E-80	Control settings have been reset to factory defaults because EEPROM checksum was incorrect.	Software has new features installed (post updated, this may be expected after the first restart and is normal). Continuous E-80 may be failing EEPROM.
E-83	EEPROM is not responding.	Failing EEPROM.
E-84	User options have been reset to factory defaults because user options EEPROM checksum was incorrect.	Software has new features installed (post updated, this may be expected after the first restart and is normal). Continuous E-84 may be failing EEPROM.
E-94	Communications has not occurred for 4 attempts.	Electrical noise. Communication cable not properly seated, not plugged in.
E-109	N7 or N9 high-limit is open.	Unit is too hot, and N7 is legitimately open. Water heater is too hot, and N9 is legitimately open. Wiring to N7 or N9 is incorrect. Board issues reading N7 or N9 input switch. Lack of water in heater tank, check for debris on drain.

AR-7HT Error Codes

Error Display	Error Description	Error Definition Comments	Reset
E-10	Sensor 0 shorted	Sensor short determined	Auto-reset w hen sensor short resolved.
E-11	Sensor 0 open	Resistance >3000 ohm (sensor not connected)	Auto-reset w hen good probe is attached, i.e. valid reading
E-30	Under Temperature	25°F under Set Point Temperature for 90 minutes.	Auto-reset w hen temp rises above the Under Temp alarm condition
E-31	Over Temperature	OVEN: 145°F over max temp range for that model. No delay.	Auto-reset w hen temperature < 145°F over max temp range.
E-38	Internal software error	Internal Software error	Call Factory
E-39	Sensor Error	Board level RTD temp circuit hardware error	Call Factory
E-70	Configuration connector error (DIP-switch)	Dip-Switch error: not set to model or invalid model	Correct DIP-switch. Turn control OFF, then ON.
E-83	EEPROM error	Bad checksum.	Reset by performing CALIBRATION.
E-90	Key Shorted	Any key > 1 min shorted	Reset w hen key no longer shorted

The Oven will not Power Up

Before you start

Set the power switch to the ON position.



WARNING: Electric shock and arc flash hazard.
Use caution when measuring line voltage.
Wear Personal Protective Equipment (PPE).

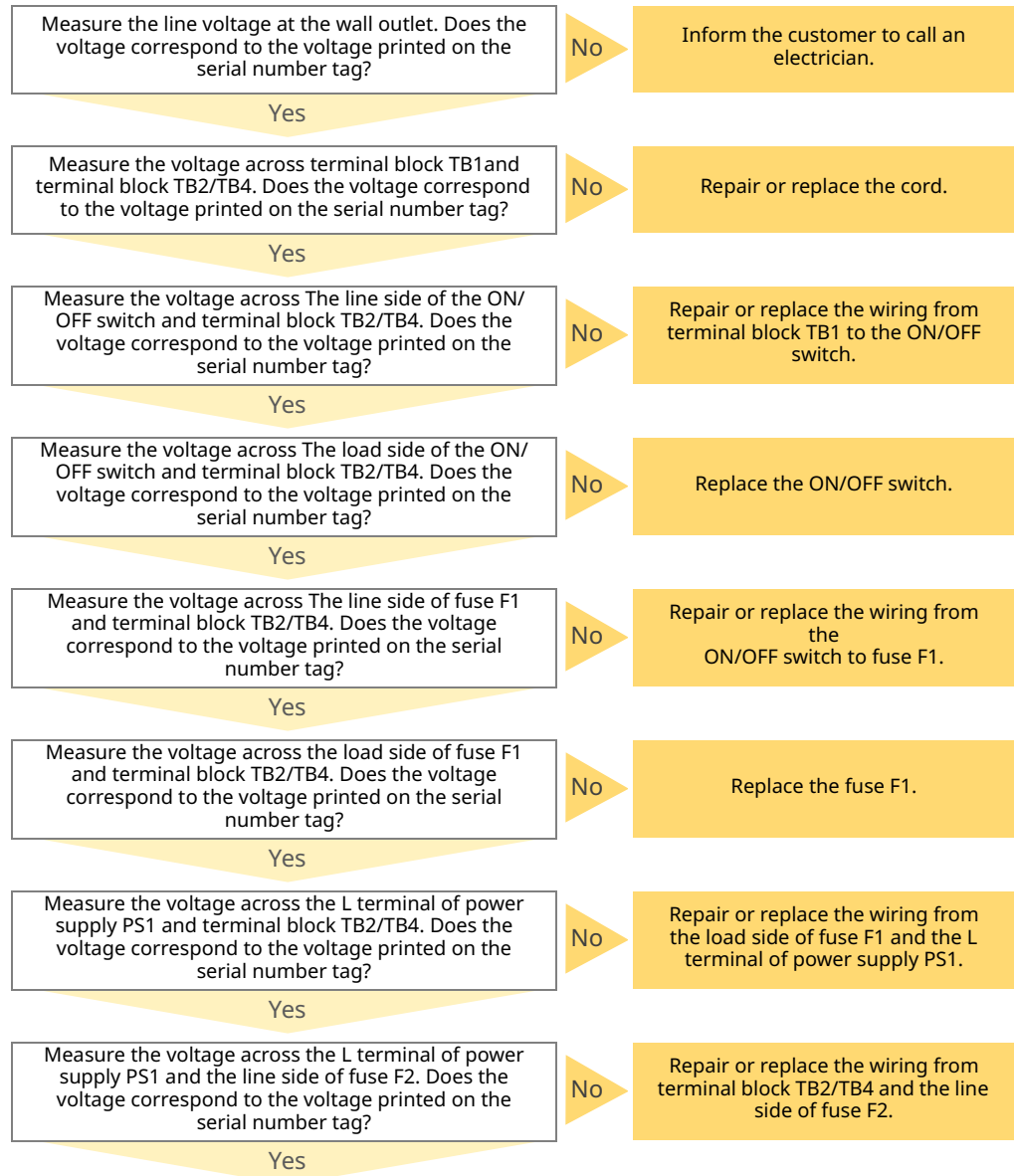

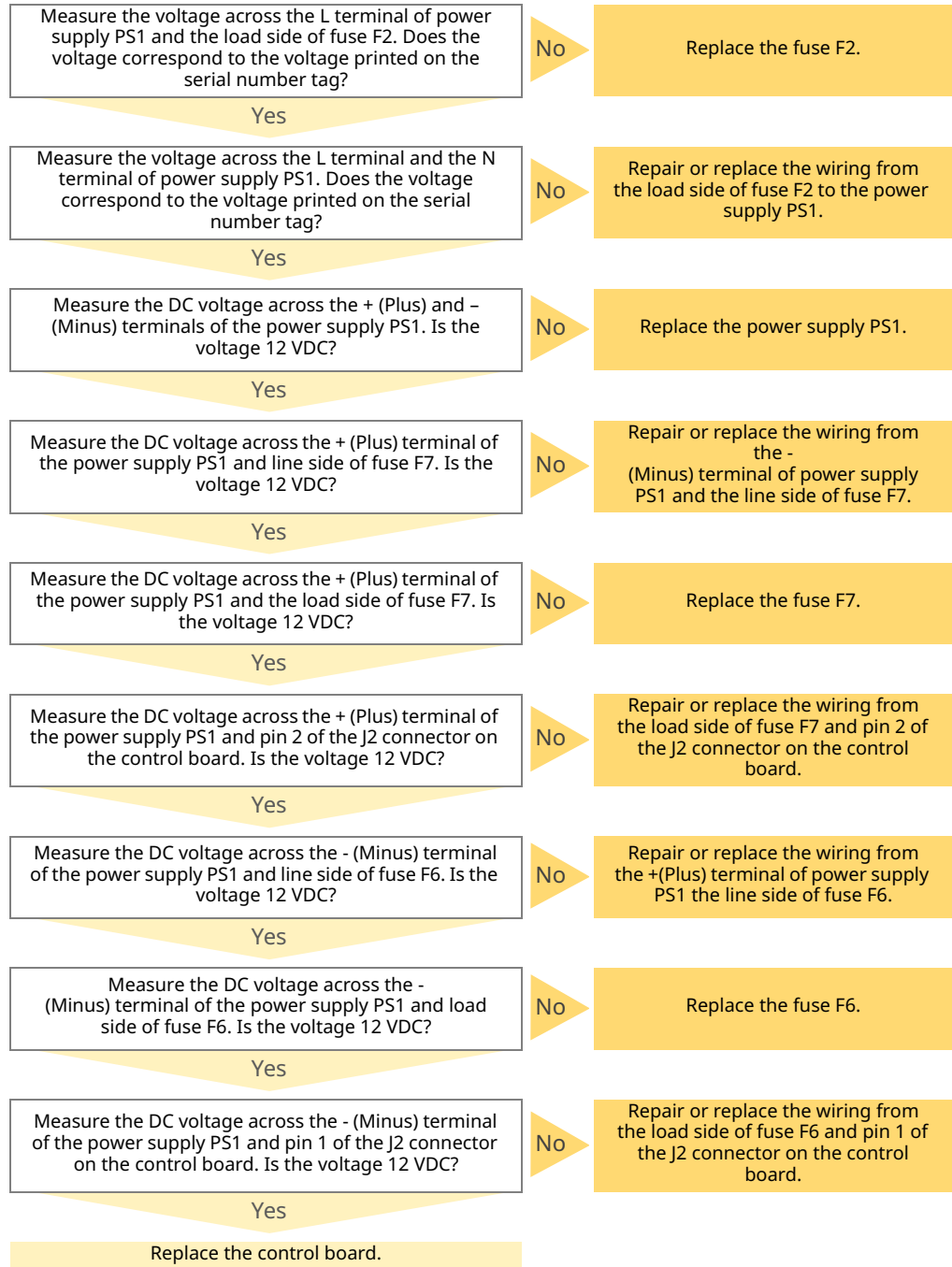

The Oven will not Heat

Before you start

- Locate the N7 HI-Limit and the N9 HI-Limit. Reset the high limits as required.
- Test the N6 100 Ohm RTD cavity sensor.
- Navigate to the Service screen. Touch the K40 icon.



WARNING: Electric shock and arc flash hazard.
Use caution when measuring line voltage.
Wear Personal Protective Equipment (PPE).

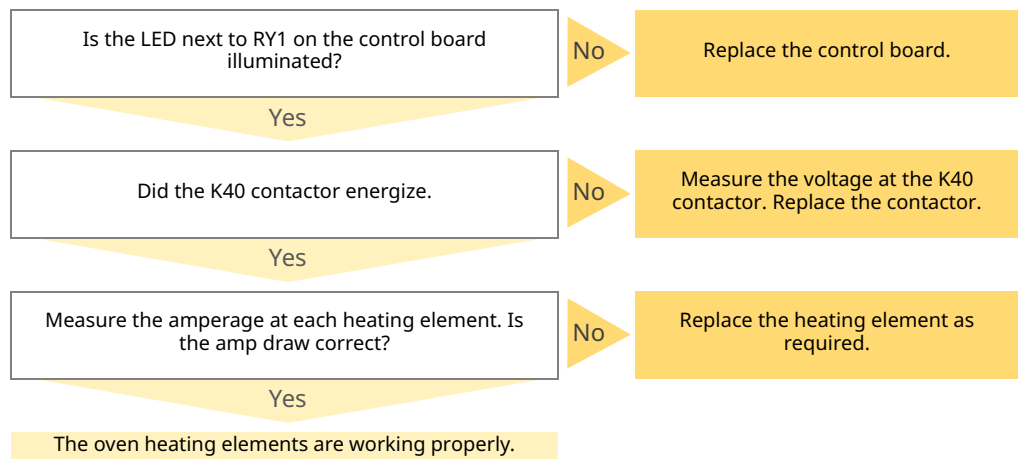

Spit Motor Inoperable

Before you start

Navigate to the Service screen. Touch the M2 icon.



WARNING: Electric shock and arc flash hazard.
Use caution when measuring line voltage.
Wear Personal Protective Equipment (PPE).

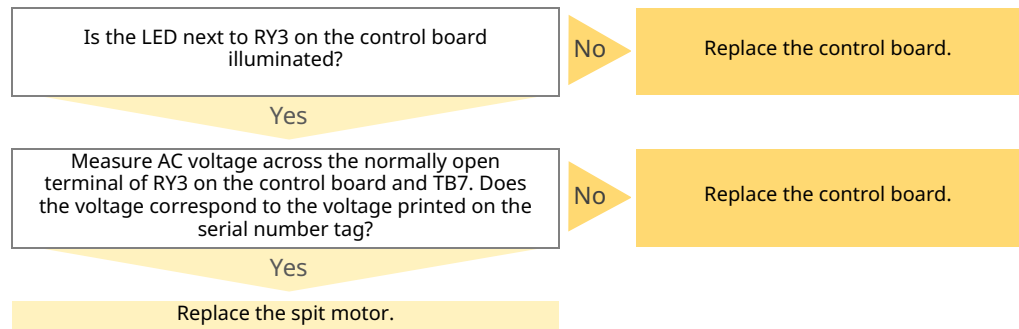

Convection Fan Motor Inoperable

Before you start

Navigate to the Service screen. Touch the M1 icon.



WARNING: Electric shock and arc flash hazard.
Use caution when measuring line voltage.
Wear Personal Protective Equipment (PPE).

Is the LED next to RY2 on the control board illuminated?

No

Replace the control board.

Yes

Measure AC voltage between the normally open terminal of RY2 on the control board and TB 7. Does the voltage correspond to the voltage printed on the serial number tag?

No

Replace the control board.

Yes

Replace the convection fan motor.

Wash Pump Inoperable

Before you start

- Navigate to the Service screen. Touch the Y4 icon.
- Locate the wash pump and make sure that the hoses are connected and secure.



WARNING: Electric shock and arc flash hazard.
Use caution when measuring line voltage.
Wear Personal Protective Equipment (PPE).

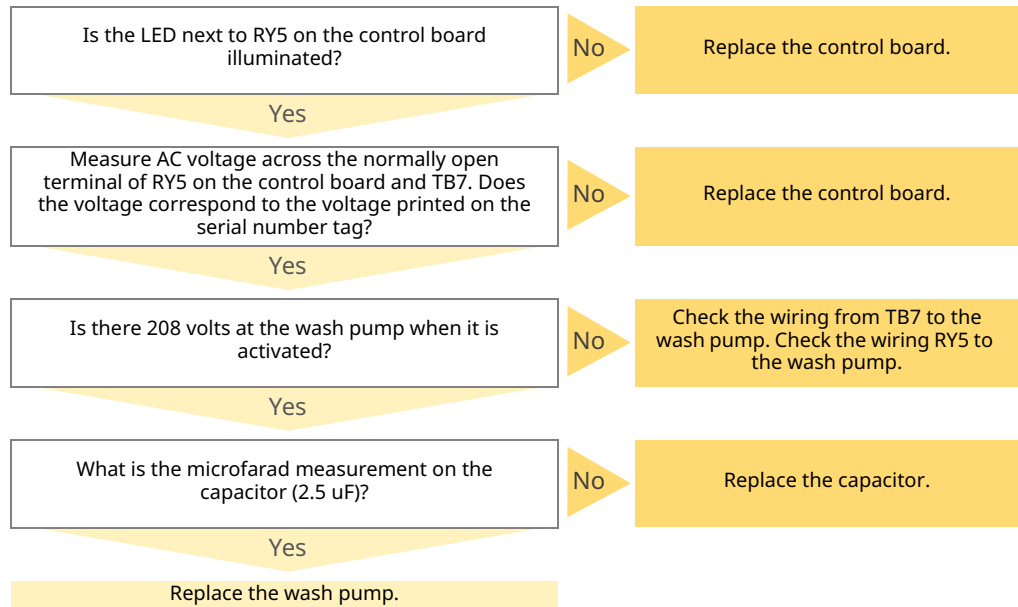

Drain Pump Inoperable

Before you start

Navigate to the Service screen. Touch the Y5 icon.



WARNING: Electric shock and arc flash hazard.
Use caution when measuring line voltage.
Wear Personal Protective Equipment (PPE).

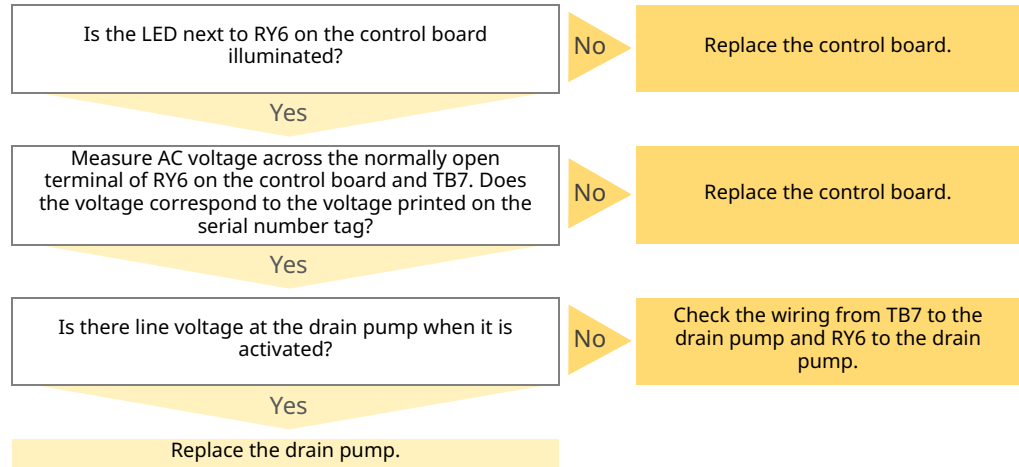

Grease Collection Pump Inoperable

Before you start

Navigate to the Service screen. Touch the Y7 icon.



WARNING: Electric shock and arc flash hazard.
Use caution when measuring line voltage.
Wear Personal Protective Equipment (PPE).

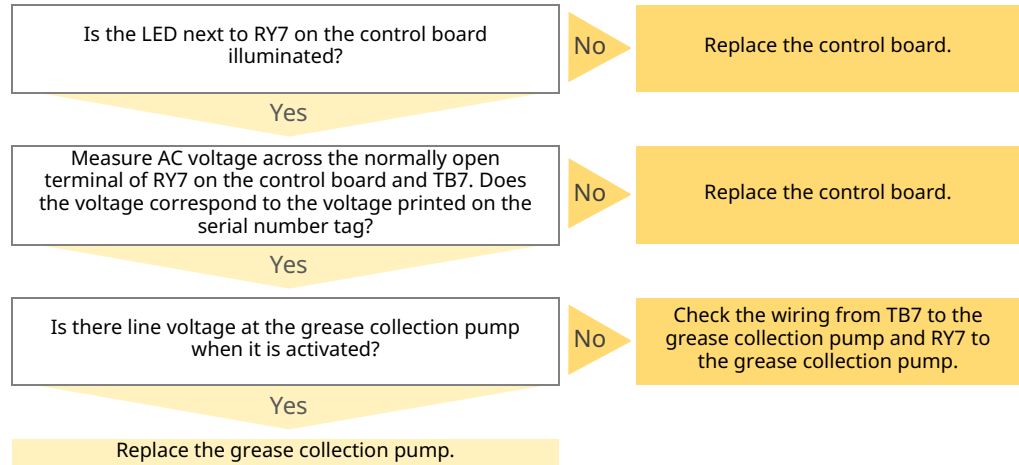

Liquid Cleaner Pump Inoperable

Before you start

Navigate to the Service screen. Touch the Y8 icon.



WARNING: Electric shock and arc flash hazard.
Use caution when measuring line voltage.
Wear Personal Protective Equipment (PPE).

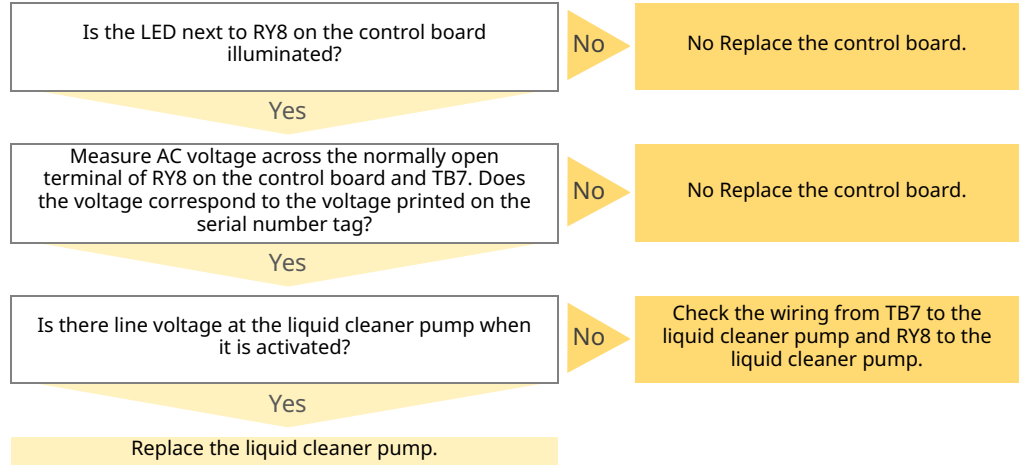

The Oven Water Heater will not Heat

Before you start

- Locate the N7 HI-Limit and the N9 HI-Limit. Reset the high limits as required.
- Test the N8 J type thermistor.
- Navigate to the Service screen. Touch the K42 icon.



WARNING: Electric shock and arc flash hazard.
Use caution when measuring line voltage.
Wear Personal Protective Equipment (PPE).

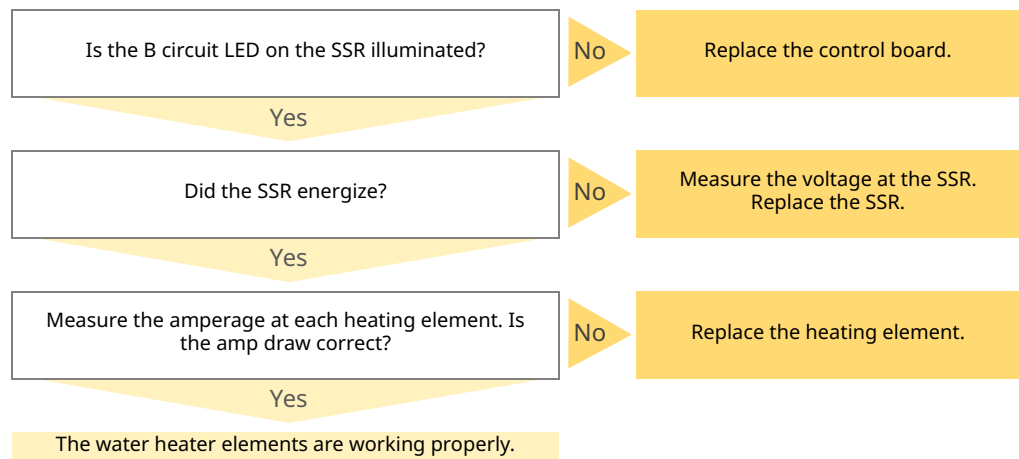

The Oven Overflows the Front Drip Tray



WARNING: Electric shock and arc flash hazard.
Use caution when measuring line voltage.
Wear Personal Protective Equipment (PPE).

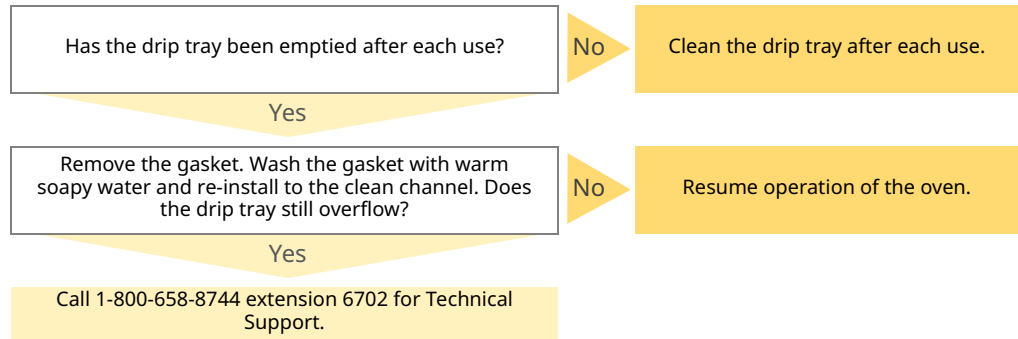

208-240V 1/3PH, 380-415V 3PH

77606

TABLE OF CONTENTS



REV.	DATE	NAME	CHANGES	REVISION
12	7/28/2022	montev	Add relay 62 and DC Liquid Cleaner Pump	12
11	3/8/2019	montev	update #404 TB4-A1	
10	4/13/2018	montev	Add cut off power to water heating element	
9	11/17/2017	montev	Add water heater and isolate convection	
8	10/18/2017	montev	Remove line on pg 3 between TB1 & TB6 per Corp Com Rrequest	
		NAME		
		77606	AR7-T	
				SCHEME 1/7

L1 TB1

12

11

10

9

8

7

6

5

4

3

2

1

L2/N* TB2/TB4*

*NOTE: 208-240 1PH AND 3PH UNITS USE L2/TB2 and 380-415V 3PH UNITS USE N/TB4

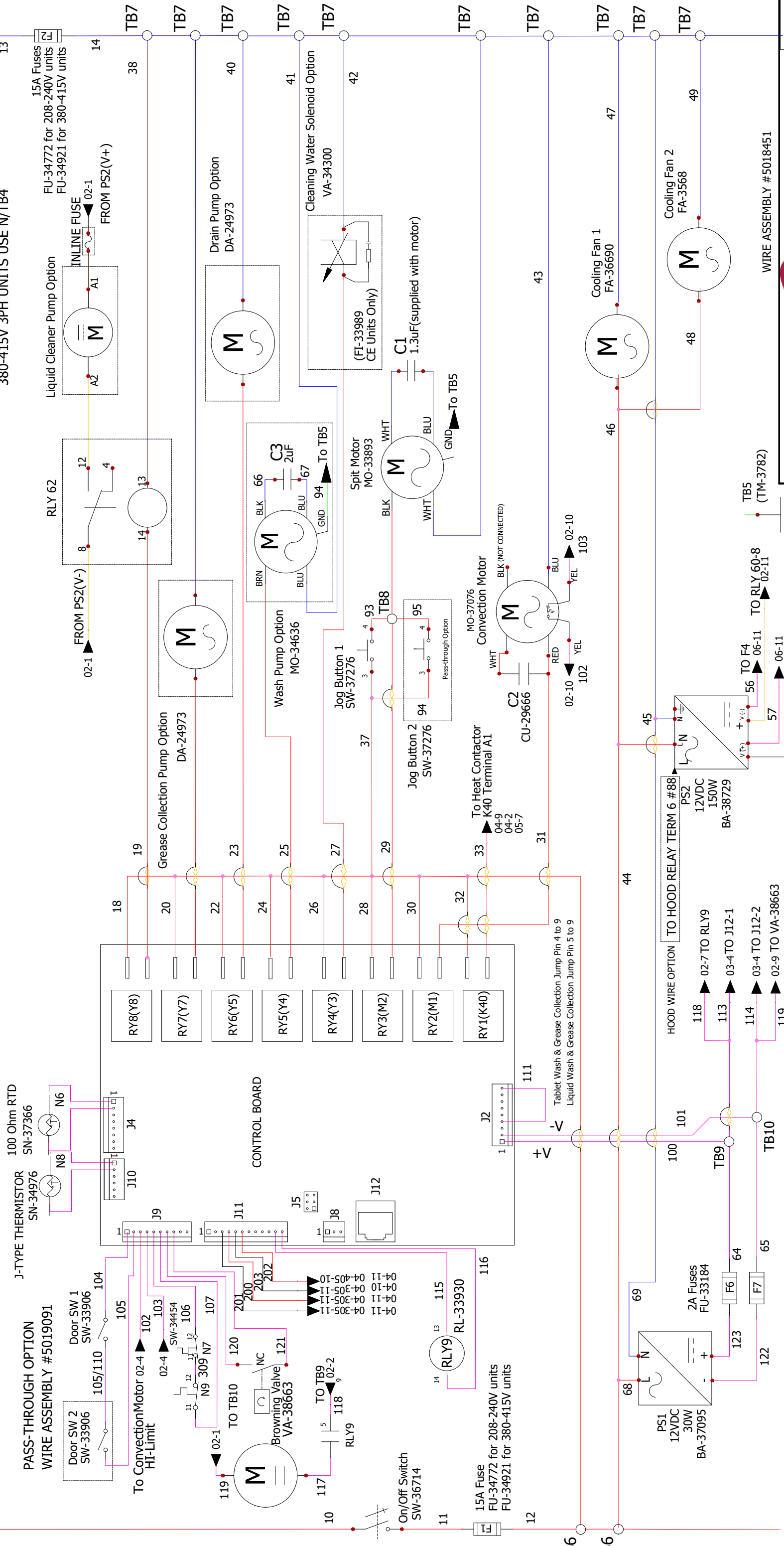

WIRE ASSEMBLY #5018451

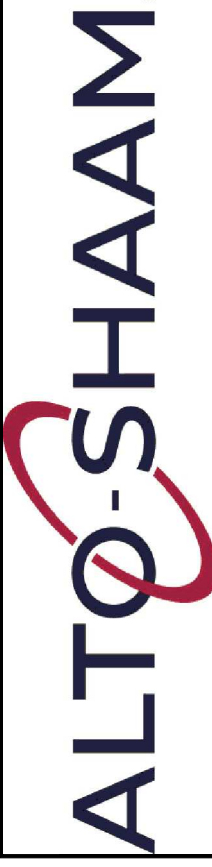

77606

AR-7T All Voltages

REVISION 12 SCHEME 2/7

WIRE ASSEMBLY #5018451

12
11
10
9
8
7
6
5
4
3
2
1

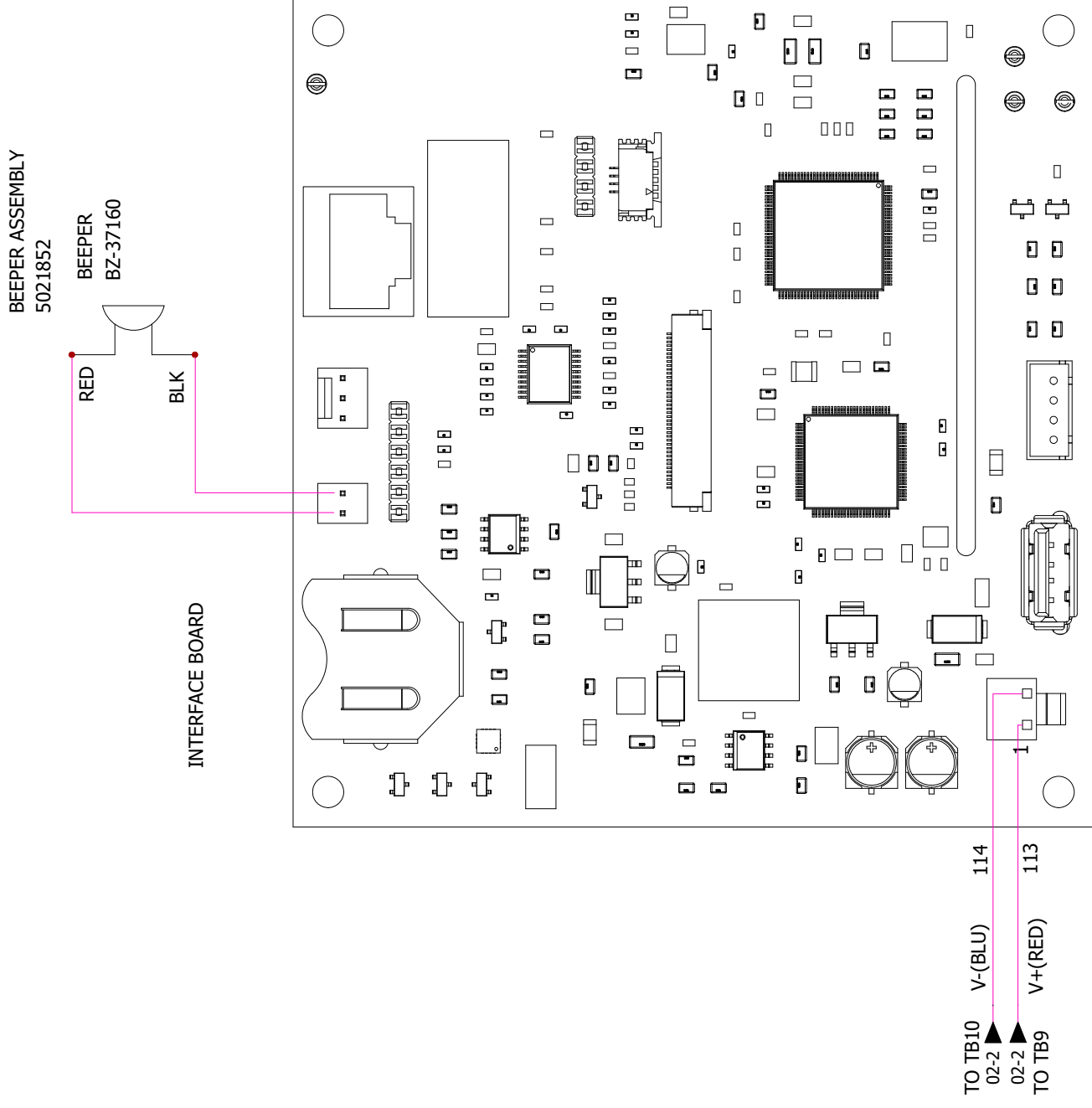

208-240V 1PH 60HZ

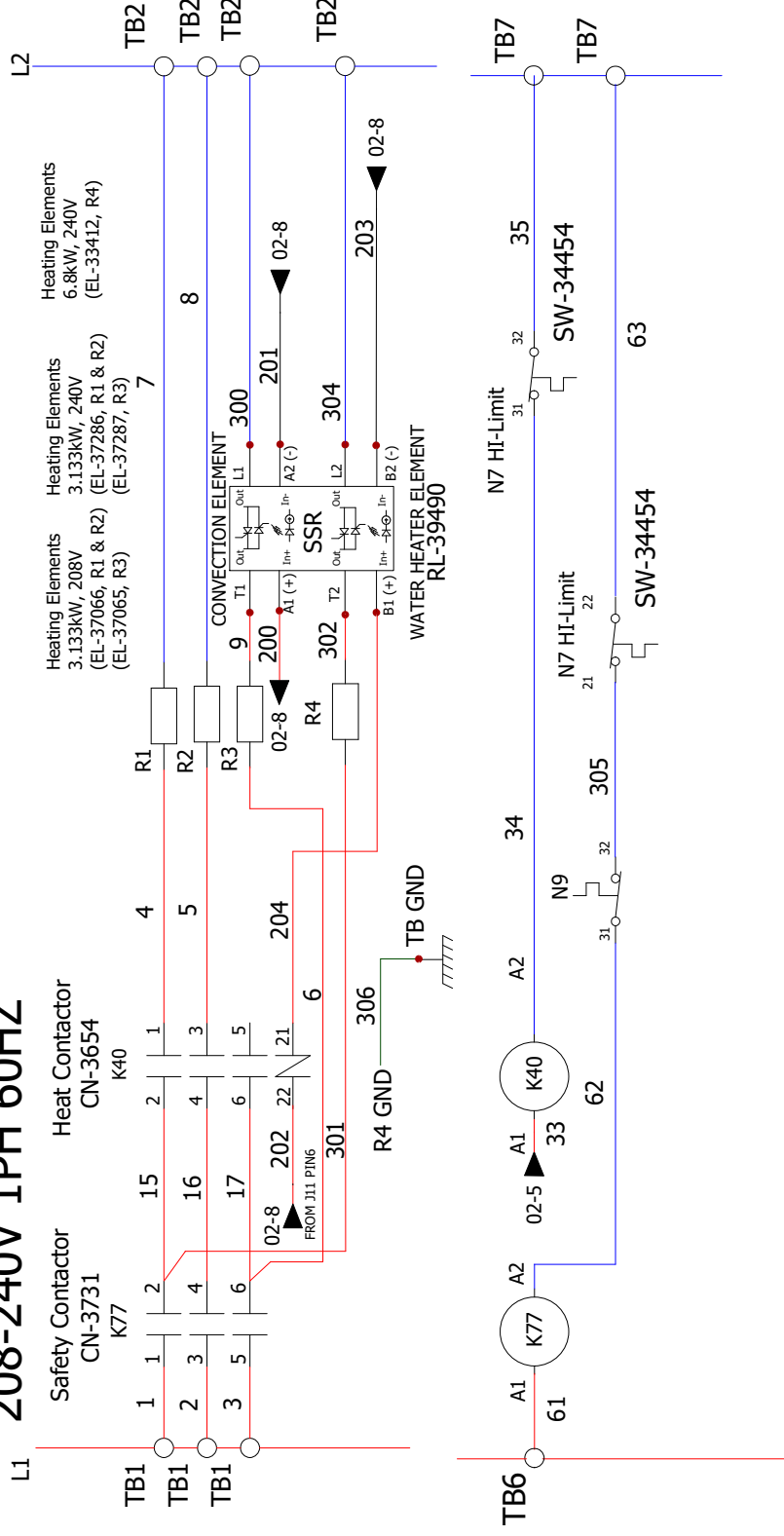

208-240V 3PH 60HZ

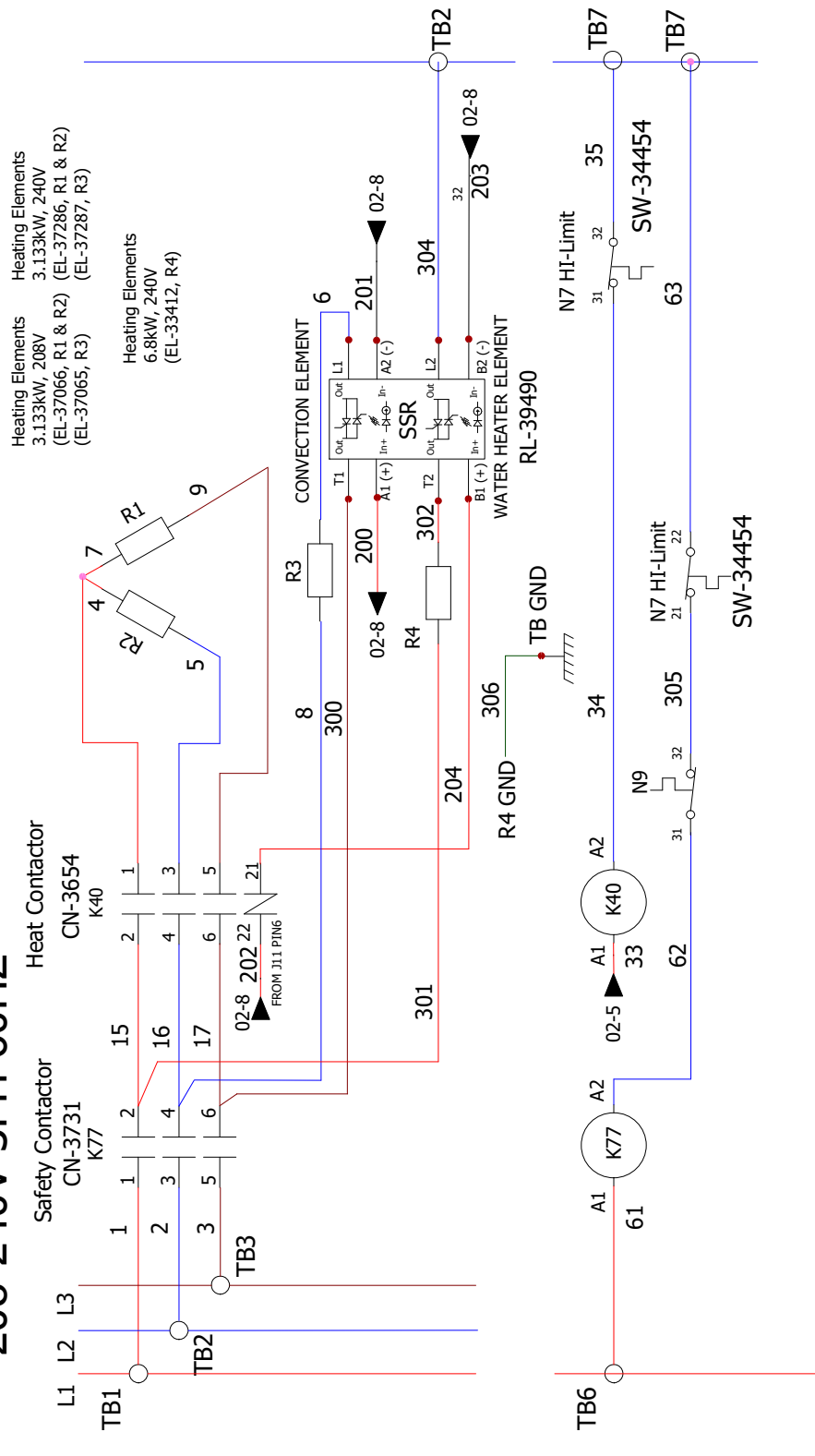

380-415V 3PH 50HZ

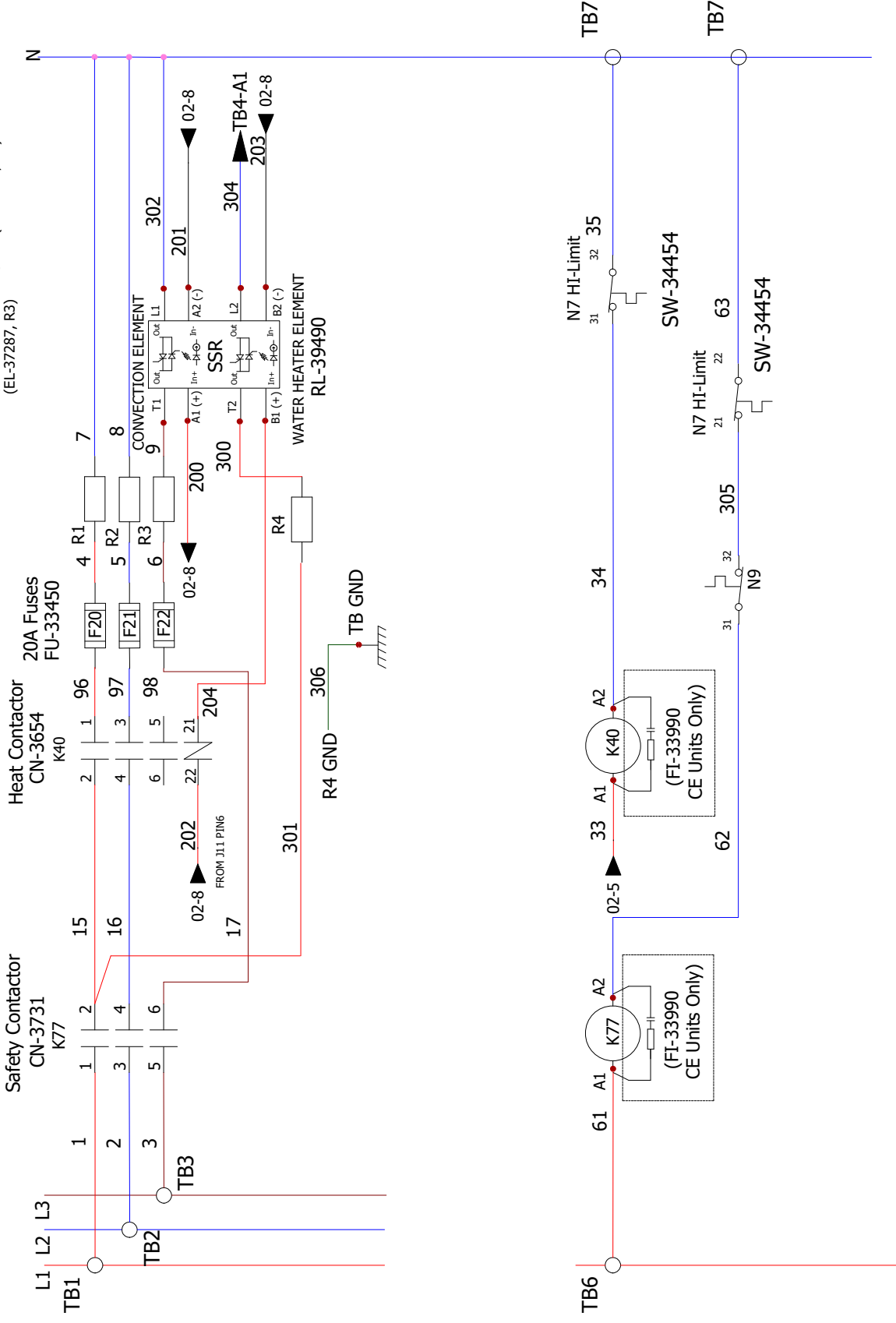

WIRE ASSEMBLY #5019089

Heating Elements
3.133KW, 240V
(EL-37286, R1 & R2)
(EL-37287, R3)

Heating Elements
6.8KW, 240V
(EL-33412, R4)

Heat Contactor
CN-3654
K40

20A Fuses
FU-33450

Safety Contactor
CN-3731
K77

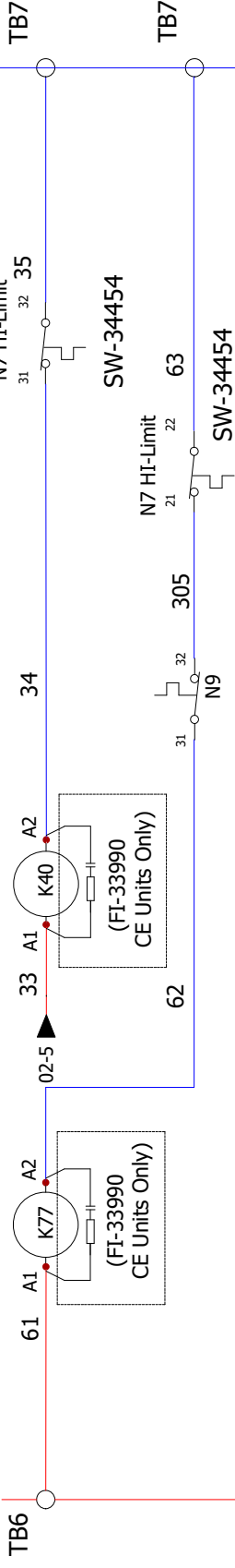

208-240V 1PH/3PH 60HZ, 380-415V 3PH 50HZ

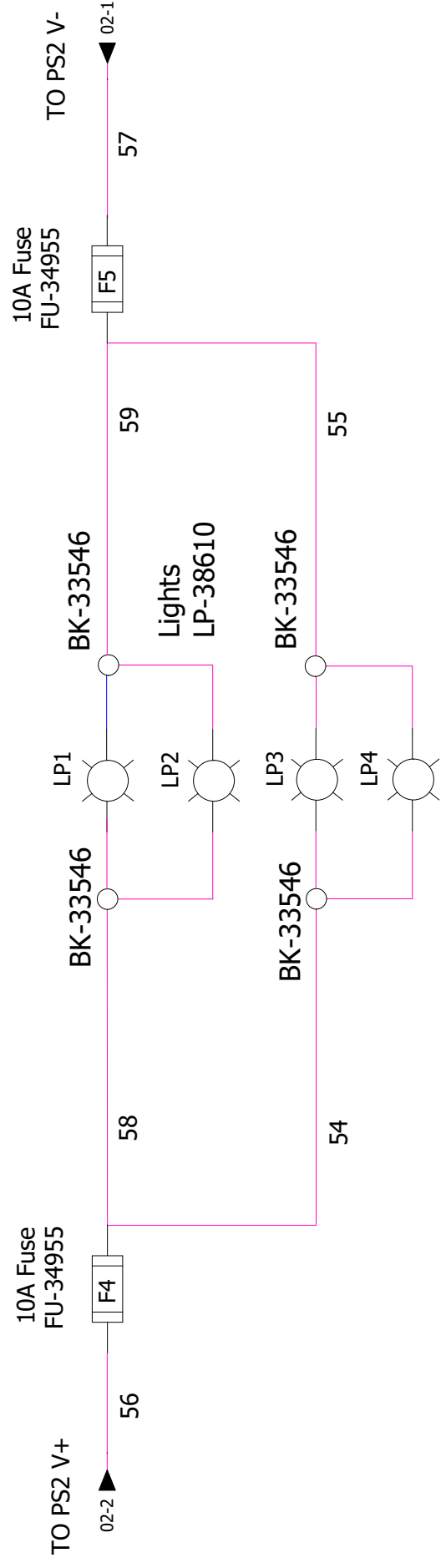

WIRE ASSEMBLY #5019083

THIS PAGE FOR ROTISSERIE HOOD OPTION ONLY

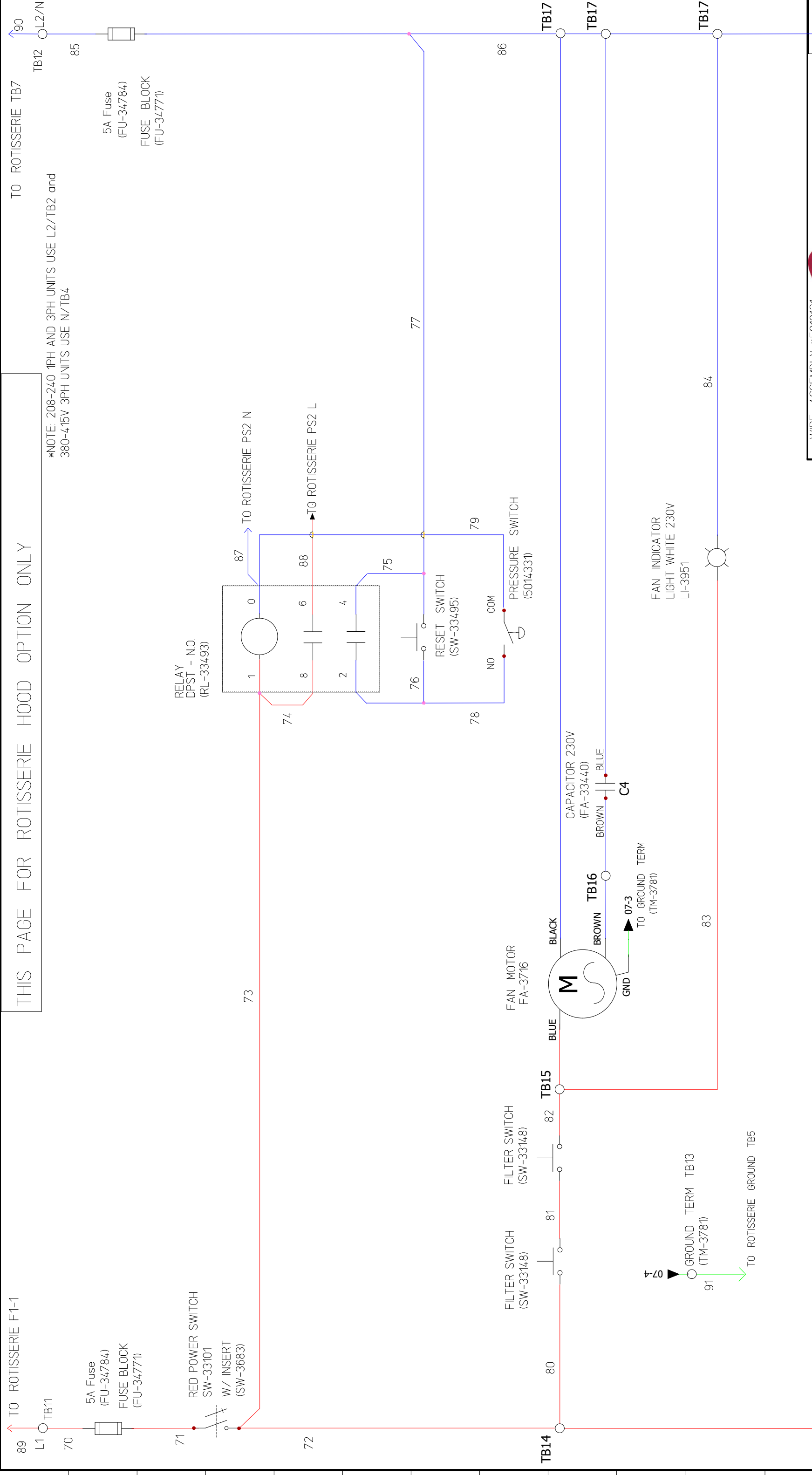

*NOTE: 208-240 1PH AND 3PH UNITS USE L2/TB2 and 380-415V 3PH UNITS USE N/TB4

WIRE ASSEMBLY #5019121

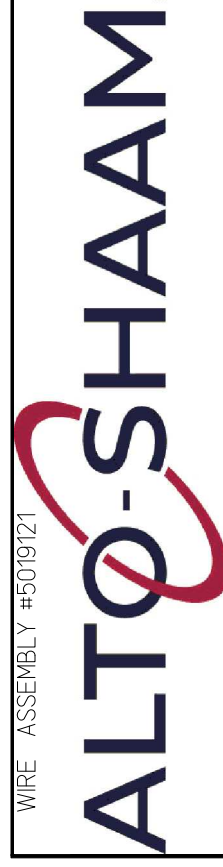

REVISION 12
SCHEME 7/7

77606 AR-7T All Voltages

12
11
10
9
8
7
6
5
4
3
2
1

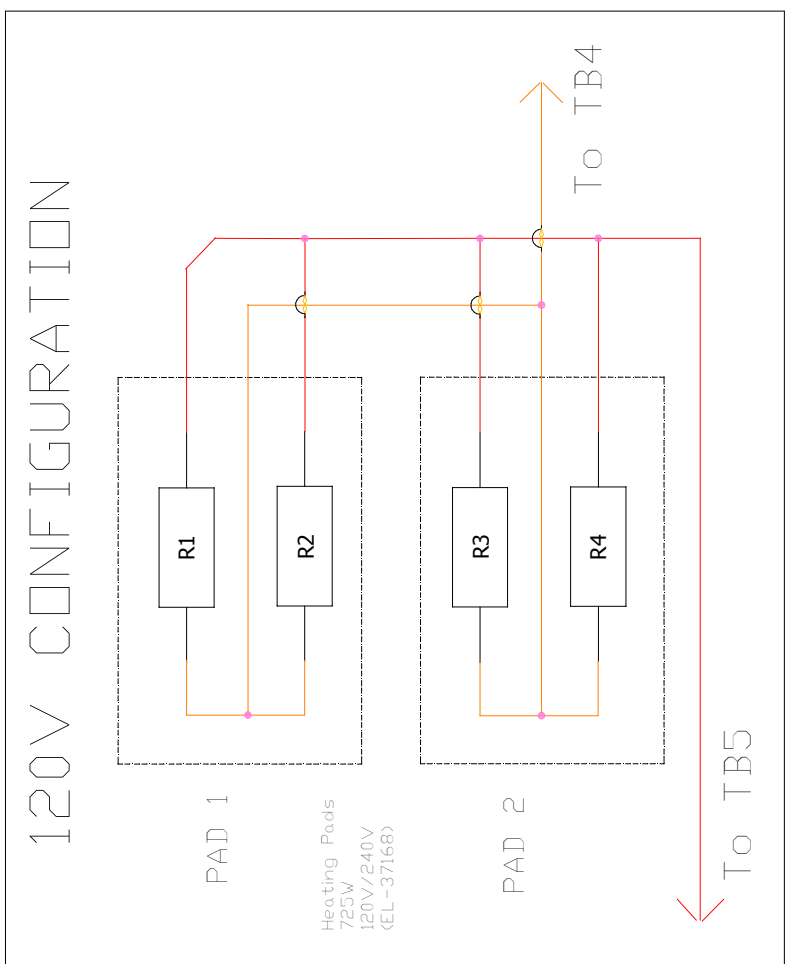
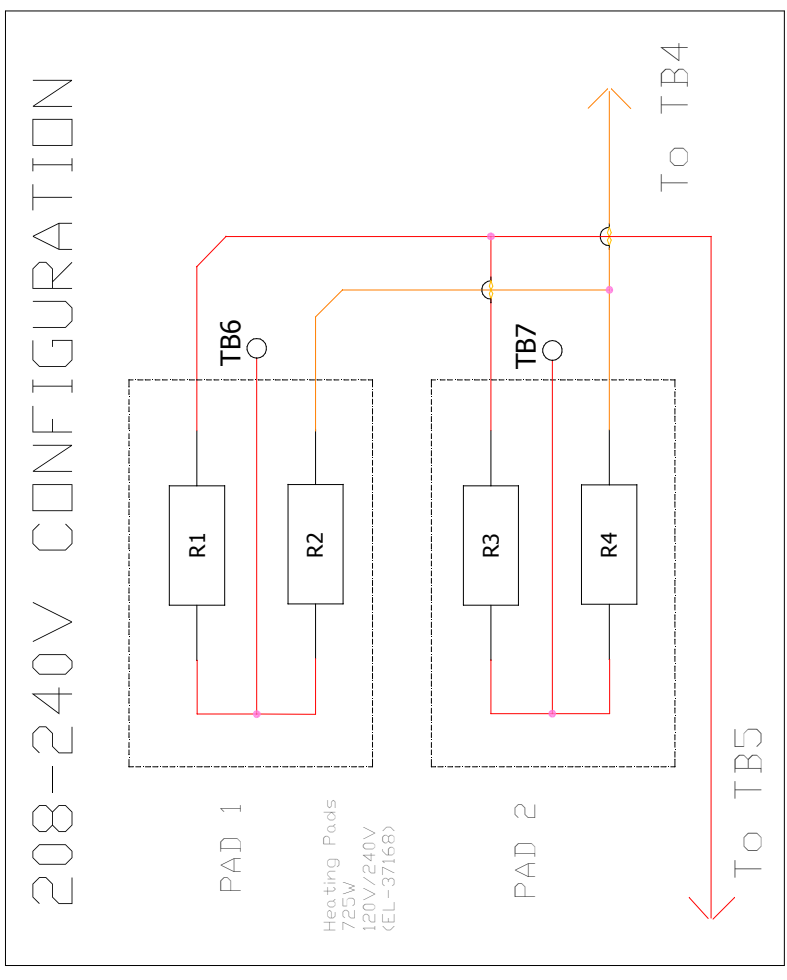
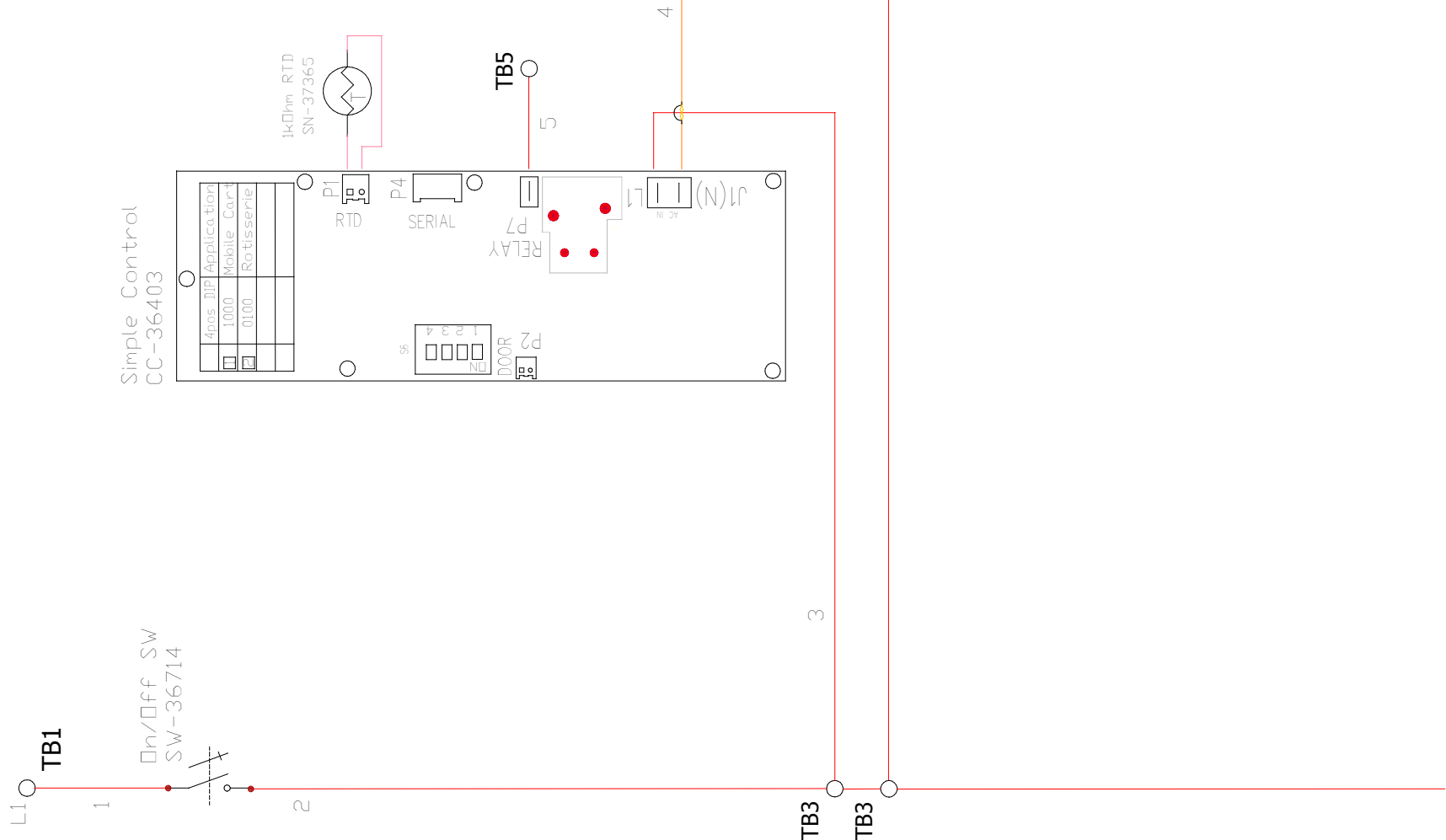

REV.	DATE	NAME	CHANGES
4	02/01/2019	montev	Eliminate lights wire extension
3	3/23/2017	nikitaa	New lights, power supply
2	11/22/2016	nikitaa	ECR 7897 Changes

WIRE ASSEMBLY #5019120
 (TM-3781)
 58

77621			AR-7H All Voltages
REVISION		4	
SCHEME		01	



ALTO-SHAAM.

Menomonee Falls, WI U.S.A.

Phone 800-558-8744 | +1-262-251-3800 | alto-shaam.com

ASIA

Shanghai, China
Phone +86-21-6173-0336

AUSTRALIA

Brisbane, Queensland
Phone 800-558-8744

CANADA

Concord, Ontario Canada
Toll Free Phone 866-577-4484
Phone +1-905-660-6781

FRANCE

Aix en Provence, France
Phone +33(0)4-88-78-21-73

GMBH

Bochum, Germany
Phone +49 (0)234 298798-0

ITALY

Padua, Italy
Phone +39 3476073504

INDIA

Pune, India
Phone +91 9657516999

MEXICO

Phone +52 1 477-717-3108

MIDDLE EAST & AFRICA

Dubai, UAE
Phone +971-4-321-9712

CENTRAL & SOUTH AMERICA

Miami, FL USA
Phone +1 954-655-5727

RUSSIA

Moscow, Russia
Phone +7 903 7932331