



OPERATOR'S MANUAL

SRTG Series Thermostat Griddle

SRTG-24 36 48 60



For Service on Your Gas Griddle:

Please call the SIERRA Service Department and ask for contact information for your local service company.

- IMPORTANT SAFETY NOTICE -

This manual contains important safety instructions which must be strictly followed when using this equipment. Please retain this manual for future reference.

Instructions must be posted in a prominent location. All safety precautions must be taken in the event the user smells gas. Safety information can be obtained from your local gas supplier.

FOR YOUR SAFETY

Do not store or use gasoline or other flammable vapors or liquids in the vicinity of this or any other appliance.

WARNING: Improper installation, adjustment, alteration, service or maintenance can cause property damage, injury or death. Read the installation, operating and maintenance instructions thoroughly before installing or servicing this equipment.



INSTALLATION, OPERATION AND CARE OF MEDIUM DUTY GAS GRIDDLES

GENERAL

Medium Duty Gas Griddles are produced with quality workmanship and materials. Proper installation, usage and maintenance of your griddle will result in many years of satisfactory performance.

Thoroughly read this entire manual and carefully follow all of the instructions provided.

Model	Number Of Burners	BTU/hr Input Rating
SRTG-24	2	60,000
SRTG-36	3	90,000
SRTG-48	4	120,000
SRTG-60	5	150,000

INSTALLATION

UNPACKING

This griddle was inspected before leaving the factory. The transportation company assumes full responsibility for safe delivery upon acceptance of shipment. Check for possible shipping damage immediately after unpacking. If the griddle is found to be damaged, save the packaging material and contact the carrier within 15 days of delivery.

Carefully unpack your griddle and make sure that no parts are discarded with packaging material. A pressure regulator designed to operate with the griddle has been supplied and must be installed before the griddle is placed into service (Refer to GAS PRESSURE REGULATOR INSTALLATION in this manual).

LOCATION

The installation location must be kept free and clear of combustibles. When installing, never enclose the bottom of the griddle with a raised curb or other constructions that would obstruct flow of air into or out of the griddle. Adequate clearance for air openings into the combustion chamber must be provided. Make sure there is an adequate supply of air in the room to replace air taken out by the ventilation system.

Do not permit air to blow directly at the griddle. Avoid open windows next to the griddle wherever possible. Avoid wall-type fans which create air cross-currents within the room.

This griddle is Design Certified for installation on a non-combustible counter with 4" legs, or combustible floor with 24" high stand.

INSTALLATION CLEARANCES

	COMBUSTIBLE CONSTRUCTION	NON-COMBUSTIBLE CONSTRUCTION
Back:	6"	0"
Sides:	6"	0"

INSTALLATION CODES AND STANDARDS

The griddle must be installed in accordance with:

In the United States of America:

- 1 State and local codes.
- 2 National Fuel Gas Code, ANSI-Z223.1/NFPA #54 (latest edition). This shall include but not be limited to: NFPA #54 Section 10.3.5.2 for Venting. Copies may be obtained from The American Gas Association Accredited Standards Committee Z223, @ 400

N. Capital St. NW, Washington, DC 20001 or the Secretary Standards Council, NFPA, 1 Batterymarch Park Quincy, MA 02169-7471

NOTE: In the Commonwealth of Massachusetts All gas appliances vented through a ventilation hood or exhaust system equipped with a damper or with a power means of exhaust shall comply with 248 CMR.

3. NFPA Standard # 96 *Vapor Removal from Cooking Equipment*, latest edition, available from the National Fire Protection Association, Batterymarch Park, Quincy, MA 02269.

In Canada:

- 1 Local codes.
- 2 CAN/CSA-B149.1 Natural Gas Installation (latest edition)
- 3 CAN/CSA-B149.2 Propane Installation Code (latest edition), available from the Canadian Gas Association, 178 Rexdale Blvd., Etobicoke, Ontario, Canada M9W 1R3

GRIDDLES MOUNTED ON STANDS WITH CASTERS

Griddles mounted on stands with casters must use a flexible connector (not supplied) that complies with the Standard for Connectors for Movable Gas Appliances ANSI Z21.69•CSA6.16, and a quick-disconnect device that complies with Gas Fuel, ANSI Z21.3•CSA6.9. In addition, adequate means must be provided to limit movement of the appliance without depending on the connector and the quick-disconnect device (or its associated piping) to limit appliance movement. Attach the restraining device at the rear of the griddle as shown in Fig. 1.

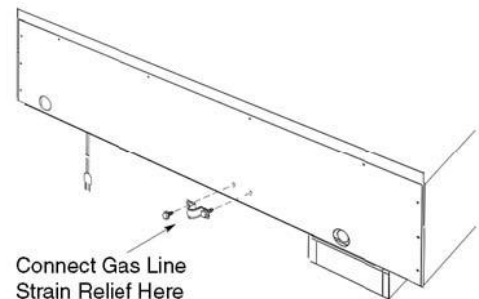

Fig. 1

If disconnection of the restraint is necessary, turn off the gas supply before disconnecting. Reconnect the restraint prior to turning the gas supply on and returning the griddle to its installation position.

Casters are only supplied on a griddle stand. If the griddle is moved for any reason the griddle should be re-leveled (see LEVELING in this manual).

FLUE CONNECTIONS

Do not obstruct the flow of flue gases from the flue, located at the rear of the griddle. It is recommended that flue gases be ventilated to the outside of the building through a ventilation system installed by qualified personnel.

From the termination of the flue to the filters of the hood venting system, a minimum clearance of 18" must be maintained.

Information on the construction and installation of ventilating hoods may be obtained from the standard for "Vapor Removal from Cooking Equipment", NFPA No. 96 (latest edition), available from the National Fire Protection Association, Battery march Park, Quincy, MA 02269.

GAS CONNECTIONS

NOTICE Gas supply connections and any pipe joint compound must be resistant to the action of propane gases.

Use a ¾" NPT gas supply line for the griddle inlet, located at the rear of the griddle. All of flexible and semi-rigid gas supply lines must comply with the applicable ANSI standard. To ensure maximum operating efficiency, this appliance must be connected with a gas supply line of solid pipe or a commercial type Flexible Connector with the net inside diameter (I.D.) as large as or larger than the gas pipe inlet on this appliance. Codes require that a gas shutoff valve must be installed in the gas line upstream of the griddle.

⚠ WARNING Prior to lighting, check all joints in the gas supply line for leaks. Use soap and water solution. Do not use an open flame.

After checking for leaks all lines receiving gas should be fully purged to remove air.

TESTING THE GAS SUPPLY SYSTEM

When the gas supply pressure exceeds ½ psig (3.45 kPa), the griddle and its individual shutoff valve must be disconnected from the gas supply piping system.

When the gas supply pressure is ½ psig (3.45 kPa) or less, the griddle should be isolated from the gas supply system by closing its individual manual shutoff valve.

GAS PRESSURE REGULATOR INSTALLATION

This griddle is supplied with a convertible gas pressure regulator preset at 4" Water Column (W.C.) for natural gas. No further adjustment should be required. Install the regulator as close to the griddle on the gas supply line as possible. Make sure that the arrow on the underside of the regulator is oriented in the direction of gas flow to the griddle (Fig. 2 on next page) and the regulator is positioned with the vent plug and conversion plug cover upright (Fig. 3 on next page).

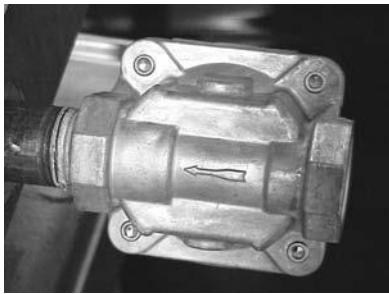

Fig. 2



Fig. 3

The supply pressure (upstream of the regulator) should be 7-9" W.C. for natural gas and 11-12" W.C. for propane gas. At no time should the griddle be connected to supply pressure greater than ½ psig (3.45 kPa) or 14" W.C.

PROPANE GAS CONVERSION

This griddle is shipped from the factory equipped with fixed burner and pilot orifices for natural gas operation. The burner and pilot orifices required to convert the griddle to propane gas are shipped with the griddle in the shipping packaging. It is recommended that a trained gas service technician with the necessary tools, instruments and skills perform the conversion.

WARNING To convert to propane, following steps must be completed:

Remove all natural gas burner orifices and install the provided propane burner orifices. See Fig. 4

1. Remove all pilot orifices and install the provided propane pilot orifices. See Fig 4.
2. Set the regulator to 10" W.C. by inverting the regulator spring plug. See Fig 5.

To convert to propane, following steps must be completed:

1. Remove all natural gas burner orifices and install the provided propane burner orifices. See Fig. 4
2. Remove all pilot orifices and install the provided propane pilot orifices. See Fig 4.
3. Set the regulator to 10" W.C. by inverting the regulator spring plug. See Fig 5.

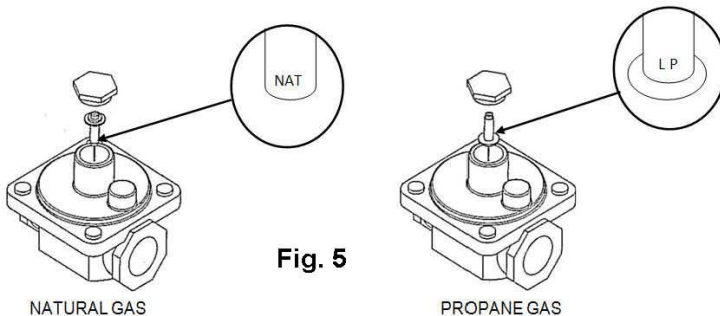
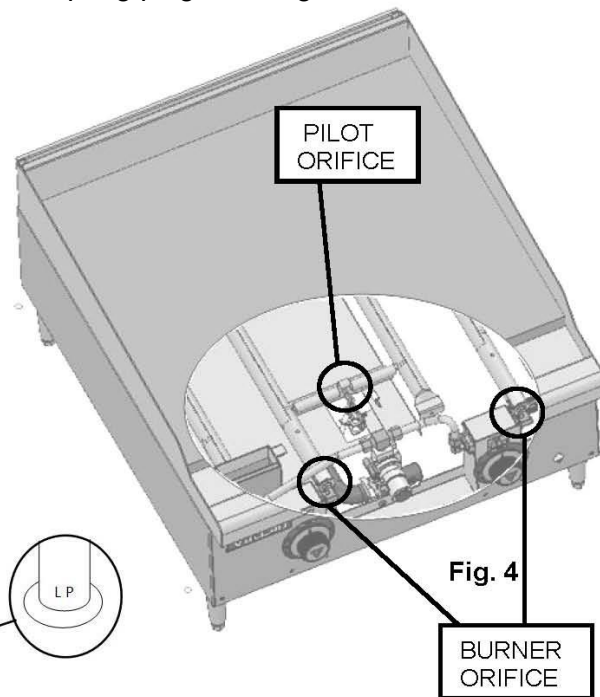

WARNING Prior to lighting, check all joints in the gas supply line for leaks. Use soap and water solution. Do not use an open flame.

OPERATION

⚠ WARNING The griddle and its parts are hot. Use care when operating, cleaning or servicing the griddle.

BEFORE FIRST USE

Remove all packing material and protective plastic from surfaces of the unit. Before leaving the factory, the griddle plate is coated with protective coating as a rust inhibitor. Remove this film when the griddle plate is being cleaned prior to its first cooking use. Heat the griddle to 200-300°F to loosen and melt the coating, then clean the surface with a non-corrosive, grease dissolving commercial cleaner, following the manufacturer's directions. Rinse thoroughly and wipe dry with a soft clean cloth. Clean all accessories.

SEASONING THE GRIDDLE

Season the griddle to avoid possible surface corrosion before first use, and after every cleaning. Heat griddle to a low temperature (300-350°F) and apply a small amount of cooking oil – about one ounce per square foot of surface. Use a soft lint-free cloth to spread the oil over the entire griddle surface to create a thin film. Wipe off any excess oil with a cloth. Repeat the procedure until the griddle has a slick, mirror-like finish. This will also help reduce the sticking of cooked food product.

CONTROLS

This model features a standing pilot that must be manually lit. The pilot is monitored by a thermocouple and pilot safety valve. If the pilot goes out, the safety valve will shut-off the gas supply to the pilot and main burners. There is one pilot and one safety valve for every two burners except on the 36" model. The 36" model has an odd number of main burners, therefore one of the sets of pilots and safety valves in these models will control only one main burner. The safety valve push buttons are aligned with pilot burners and the pilot sight holes are off centered 3/4" to the right. The pilot burners are inset approximately 7" from the front panel. See cutaway view on page 8.

Each 12" section of the griddle is independently controlled by a mechanical snap-action thermostatic valve. The thermostats have an operating range of 200 to 450 degrees. Once pilots are lit, turning the thermostats to the desired setting is all that is required to put the unit into service.

SRTG PILOT LIGHTING PROCEDURE

1. Turn the main gas shut-off valve and all thermostats to the OFF position. Wait 5 minutes to allow any gas that may have accumulated in the burner compartment to escape.
2. Turn the main gas shut-off valve ON.
3. Depress and hold the safety valve button while lighting the corresponding pilot. You will have to reach under the front of the unit to light with an outside ignition source(such as a lit taper, etc.) while viewing thru the pilot sight hole.
4. When the gas at the pilot has been burning for about 45 seconds, release the safety valve button. If the pilot does not remain lit, repeat the operation allowing more time before releasing the button. The amount of time necessary to hold the safety valve button will increase at the initial installation of the unit and if the main gas supply has been turned off for a long period of time. It may be necessary to adjust the pilot valve to increase gas to the pilot.
5. Repeat steps until all pilots are lit.
6. If after completing steps 1-5 pilot does not light, turn off the main gas shut-off valve and contact an authorized service agency.

USING THE GRIDDLE

To preheat, turn the burners on about 20-25 minutes before cooking.

A uniform and systematic approach to loading the griddle will produce the most consistent product results.

The griddle plate is steel, but the surface can be scored or dented by careless use of a spatula or scraper. Be careful not to dent, scratch, or gouge the plate surface. Do not try to knock off loose food that may be on the spatula by tapping the corner or the edge of the spatula on the griddle surface.

ZONE COOKING

This griddle features a tubular U-shaped burner in each 12” section, each controlled by independent thermostats. Each 12” section is a separate cooking zone, and allows cooking a wide variety of products over a single griddle plate.

When zone cooking, it is suggested that you start with your lowest temperature setting at either side of the griddle, increasing the zone temperature as you move up the zone line. These zone cooking guidelines will vary depending on product temperatures, size and shape. This guide should be adjusted to suit your product and operational cooking preference.

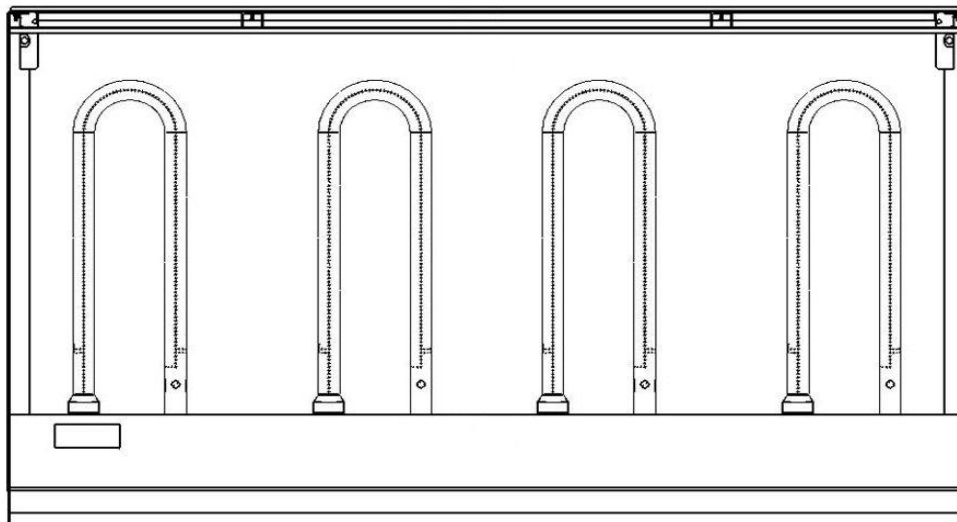

ZONE 1 (300°F)	ZONE 2 (350°F)	ZONE 3 (350°F)	ZONE 4 (400°F)
PRODUCT Sausage Eggs (Hard Fried) Eggs (Scrambled) Burger (Well Done) Steak (Well Done) Chicken Breast Frozen Foods Pork Chops	PRODUCT Pancakes French Toast Bacon Omelet Hash Browns Canadian Bacon Eggs (Sunny Side Up) Boiled Ham Steak (Medium Well) Fresh Burger (Medium Well) Small Frozen Burger (Medium Well)		PRODUCT Steak (Rare) Stir Fry Vegetables Salmon Fish Cakes Lobster Scampi

CLEANING THE GRIDDLE

Empty the grease drawer as needed throughout the day and regularly clean at least once daily.

Clean the griddle regularly. A clean griddle always looks better, lasts longer and performs better. To produce evenly cooked, perfectly browned griddle products keep the griddle plate clean and free of carbonized grease. Carbonized grease on the surface hinders the transfer of heat from the griddle surface to the food, resulting in spotty browning and loss of cooking efficiency. Carbonized grease tends to cling to griddle foods, giving them a highly unsatisfactory and unappetizing appearance.

To keep the griddle clean and operating at peak efficiency, follow these procedures:

AFTER EACH USE

Clean the griddle with a wire brush or flexible spatula.

ONCE PER DAY

Thoroughly clean the griddle back splash, sides and front. Remove, empty and wash the grease drawer in the same manner as an ordinary cooking utensil.

ONCE PER WEEK

Clean the griddle surface thoroughly. Use a griddle stone, screen, or Scotch Bright™ pad on the surface as necessary. Rub with the grain of the metal while the griddle is still warm (not hot). A detergent may be used on the plate surface to help clean it, but be sure the detergent is thoroughly removed by flushing with clear water.

After removal of detergent the surface of the plate the griddle should be seasoned according to the instructions in this manual.

Clean stainless steel surfaces with a damp cloth and polish with a soft dry cloth. To remove discoloration, use a griddle cleaner.

If the griddle usage is very high, consider conducting this weekly cleaning procedure more than once per week.

ADJUSTMENTS

CALIBRATION

1. Each thermostat controls a 12" zone of the griddle. Using a Surface Probe temperature measurement device, observe the temperatures at the center points of the cooking zones. These points are located by starting 6" from the side splash (left or right) and every 12" across the width of the griddle, with all points located 12" back from the front edge of the griddle plate. NOTE: Use of infrared thermometers is not recommended. These devices are highly sensitive to surface color (clean or dirty), angle of reading and distance from the unit.

2. Set thermostats to 350°F and allow to stabilize, allowing the burner to cycle ON and OFF at least two times.

3. Watch for burner to cycle OFF, then measure the temperature for that zone. The temperature should be 350°F ±15°F. If not, continue to Step 4.

4. a. Carefully loosen the knob set screw. DO NOT allow the knob to turn. Carefully remove the knob from the thermostat shaft, exposing the temperature dial.

b. Loosen screws on the temperature dial and adjust to that the temperature indicated by the knob arrow matches the griddle plate temperature reading. Knob will have to be placed back on the shaft to verify adjustment.

IMPORTANT: NEVER ADJUST THE SCREW IN THE CENTER OF THE THERMOSTAT SHAFT. This will ruin the factory calibration; the thermostat will no longer operate properly and may need to be replaced.

5. Once calibration is achieved, tighten the temperature dial screws and knob set screws.

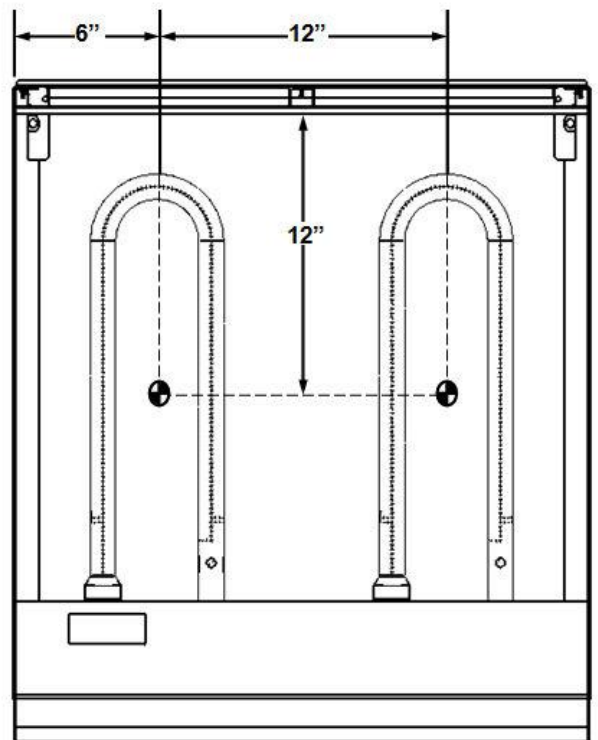

LEVELING griddle must be level (side-to-side and front-to-back) during operation to ensure proper performance. Improper leveling can result in uneven temperature distribution, cold spots, and possibly damaged components.

- 1 Place a level on the griddle.
- 2 Adjust legs by turning the bullet feet at the bottom of each leg. Using pliers or a crescent wrench, turn the feet counter-clockwise to increase height, and clockwise to decrease height until leveling is achieved. Do not extend the legs more than 1- $\frac{3}{4}$ ".

PILOT ADJUSTMENT

Using a flathead screwdriver, turn the slotted hex-head pilot adjustment screw clockwise to decrease the flame, and counterclockwise to increase the flame.

SHUTDOWN OF GRIDDLE

1. Turn thermostats to the OFF position to cut off burners.
2. The pilots will remain lit and monitored by the safety valve as long as the main gas supply is on.

EXTENDED SHUTDOWN

1. Shut off the main gas supply valve.
2. Apply a heavy coat of vegetable oil over the griddle plate to inhibit rust.

MAINTENANCE

⚠ WARNING The griddle and its parts are hot. Use care when operating, cleaning or servicing the griddle.

LUBRICATION

There are no parts on this griddle that require lubrication.

VENT

Daily, when the griddle is cool, check the flue and clear any obstructions.

SERVICE AND PARTS INFORMATION

Contact the Service Agency in your area to obtain service and parts information. For a complete listing of Service and Parts depots refer to or <http://mvpgroupcorp.com>

When calling for service, the following information should be available from the appliance identification plate: Model Number, Serial Number and Gas Type.