



SRCO-E

Installation and Operation Manual

208/240V/60Hz 3 phase



Please read this manual completely before attempting
to install, operate or service this equipment



5659 ROYALMOUNT AVE.
MONTREAL, QC H4P2P9
TEL (514) 737-9701; 1-888-275-4538

12000 BISCAYNE BLVD. STE108
MIAMI, FL 33181
TEL (786)-600-4687; 1-844-218-8477

sales@mvpgroupcorp.com www.mvpgroupcorp.com

IMPORTANT WARNING AND SAFETY INFORMATION

FOR YOUR SAFETY:

Do not store or use gasoline or other flammable vapors or liquids in the vicinity of this or any other appliance.

⚠ WARNING: Improper installation, adjustment, alteration, service or maintenance can cause property damage, injury or death. Read the installation, operating and maintenance instructions thoroughly before installing or servicing this equipment.

THIS MANUAL MUST BE RETAINED FOR FUTURE REFERENCE.

SPECIFICATIONS

208/240V/60HZ 3 PHASE

TOTAL KW	VOLTAGE	AMPS 3 PHASE
10KW	240	31
10KW	208	27

INSTALLATION INSTRUCTIONS

A. QUALIFIED PERSONNEL

These installation instructions are for the use of qualified installation and service personnel only. Installation or service by other than qualified personnel may result in damage to the oven and/or injury to the operator.

Qualified installation personnel are those individuals, firms, companies or corporations which either in person or through an agent is engaged in and responsible for:

- The installation of electrical wiring from the electric meter, main control box or service outlet to the electrical appliance. Qualified installation personnel must be familiar with all precautions required and have complied with all requirements of state and local authorities having jurisdiction. See: National Electrical Code, ANSI/NFPA 70.

B. DELIVERY AND INSPECTION

SIERRA does everything within its power to insure you received your oven in good condition. They are strapped down on heavy wooden skids and surrounded by heavy "tri-wall" carton stop to prevent shipping damage. They have all been carefully inspected before they were packaged and consigned to the carrier.

Upon delivery of your SIERRA oven:

- Look over the shipping container, carefully noting any exterior damage on the delivery receipt, which must also be signed by the driver/ delivery person.
- Uncrate and check for any damage, which was not evident on the outside of the shipping container. This is called concealed damage. The carrier must be notified within five (5) days of the delivery of the oven and the carton, skid and all packaging materials must be retained for inspection.

SIERRA cannot assume liability for loss or damage suffered in transit. The carrier assumes full responsibility for delivery in good order when the shipment was accepted. However, we are prepared to assist you in filing your claim.

C. LOCATION OF THE OVEN

Proper planning and placement of the oven will give you the best results in terms of long-term user convenience and satisfactory performance. We urge you to give adequate thought in the placement of your oven prior to its arrival.

- The oven should be placed in an area that is free from drafts and accessible for proper operation and servicing.
- Refer to the Oven Placement Clearances Chart before installing the oven.

OVEN PLACEMENT CLEARANCES CHART

	COMBUSTIBLE	NON-COMBUSTIBLE
Right Side	1"	0"
Left Side	1"	0"
Rear	3"	3"
Floor	8"	8"

It is also important not to obstruct the natural flow of ventilation air if the oven is to operate properly. This oven should not be installed on a curb base or sealed to the wall. Either condition can restrict the flow of air to or prevent proper ventilation of the blower motor. The blower motor has a thermal protection device, which will trip, because of excessive ambient temperatures at the back of the oven. This condition should be corrected immediately to avoid damaging the oven permanently.

Before making any connections to the oven, check the specification plate to be sure the oven specifications concur with the voltage and phase to be supplied to the oven.

The specification plate is located behind the lower front panel. To access the specification plate, loosen the four screws below the doors, and pull the panel outward.

The specification plate bearing the oven's serial number is attached to the underside of the upper ledge above the control panel.

D. ELECTRICAL CONNECTIONS

The oven is supplied for connection to a 208 or 240 volt three phase grounded circuit. The electric motor, oven lights, indicator lights and control circuits are connected internally and require no secondary power supply. Before making any connections to these units, check the specification plate to assure that the voltage and phase of the oven is compatible with the electrical supply. When installing, all ovens must be electrically grounded in accordance with local codes or in the absence of local codes, with the National Electrical Code, ANSI/NFPA 70 (in Canada – CSA Std. C22.1). Wiring diagrams are located in the control compartment

area. Standard wiring schematics are also included at the back of this manual.

Note to Electrical Inspector: Inspection of electrical connection should be accomplished by the removal of the lower finishing piece. This is done by loosening the four screws located in the door opening under the doors.

E. OVEN ASSEMBLY

Before assembling and installing the oven, please check to make sure that all necessary parts are present. In addition to the oven itself, there will also be four legs, four feet or four casters, the vent guard, (for double sections: retaining clips & vent riser) and miscellaneous hardware. Please check the interior of all oven sections for the parts needed to assemble and install the oven(s).

Leg Attachment

- Once the oven has been removed from the carton, lay it on its left side (the side without the controls).
- hold the leg and align with the threaded hole in the front corner of the bottom of the oven. Carefully start the bolt in the corner (avoid cross threading).
- Align the other two leg plate holes in the leg with those in the oven bottom and secure each leg using the remaining two leg bolts. Repeat this process for all legs.
- Raise the oven up on the legs.
- Level the oven by turning the adjustable feet in or out as needed.

Caster Installation

- Casters are available as an option for both the single and double oven sections.
- The installation of casters requires the removal of the adjustable feet from the legs. This is done by placing the bit of a large screwdriver against the lip of the foot and rapping the screwdriver to drive the foot out of the leg. The caster is then inserted fully into the opening where the foot came out and the locking nut tightened to expand the compression sleeve of the caster.

NOTE: The casters with locking brakes are best mounted on the front side of the oven for easier access.

NOTE: If you plan to use casters, a fixed restraint of the Proper length must be incorporated to secure the oven to a non-movable surface to eliminate strain on the power cord. If the oven is removed from its normal position, the restraint must then be reattached when returned.

Double Sections

- Secure the short legs to the bottom of the lower section as described in previous section.
- Casters are installed by the method described for single section ovens in the previous section.
- Place upper section on top of lower section and align all edges of the ovens.
- Locate securing clips and align with holes on rear frames of oven section, install three screws each as provided and tighten.
- At the rear of the oven, install the flue connector by sliding it up through the flue vent opening in the top of the oven and over the upper flue vent. Push it flush with the back of the oven then slide it down over the lower flue vent. Attach with screws provided.
- Install flue guard or draft hood adapter and draft hood and draft hood collar to upper section.

F. ADJUSTMENTS ASSOCIATED WITH INSTALLATION

Each oven section and all its component parts have been tested thoroughly and inspected before the oven was shipped from the factory. However, it is sometimes necessary to further test or adjust the oven once it has been installed. Such adjustments are the responsibility of the Dealer or Installer. These types of adjustments are not considered defects, rather a normal and routine part of the proper installation of the equipment.

These adjustments include but are not limited to:

- Adjustments and recalibration of the thermostat
- Adjustment to the doors.
- Leveling.
- Tightening of fasteners.

▲ WARNING No installation should be considered complete without proper inspection and, if necessary, any adjustments by qualified service or installation personnel.

OPERATING INSTRUCTIONS

The information in this section is intended for the use of qualified operating personnel. Qualified Operating Personnel are those individuals who have carefully read the information contained in this manual, are familiar with the function of the oven and/or have had experience with operating the equipment described. We recommend following these instructions to insure optimum performance, long life and trouble-free service from your oven.

THE SRCO-E SERIES OF CONVECTION OVENS

▲ WARNING

Do not attempt to operate oven during a power failure.

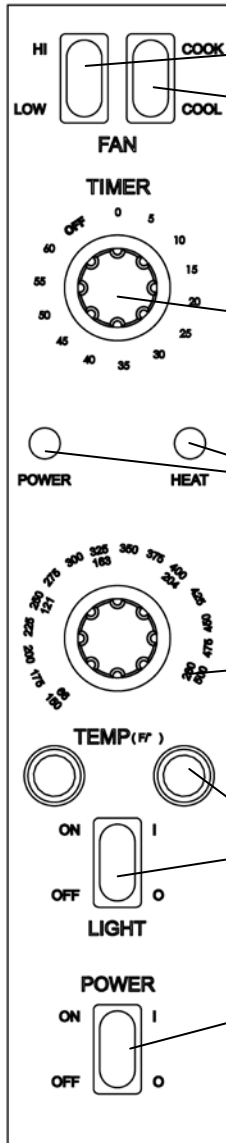

- 1. Fan speed**
Use to select fan speed, HI or LOW, The appropriate speed is determined by the type of food being cooked.
- 2. Fan Mode**
In COOK mode, the fan runs continuously except when the doors are open. The fan does NOT cycle with operation of burners. In COOL mode, the fan runs continuously even if the doors are open. Since the burners will not operate if the oven doors are open, to rapidly cool the oven after cooking is completed, open the doors and switch the fan mode to COOL.
- 3. Cook Timer**
Turn knob to set a time duration. An alarm will sound when the timer runs out. The timer is a reminder to the user; **the timer does not control the oven.**
- 4. Power on Light**
- 5. Heat-On indicator**
- 6. Cook Temperature Control**
Turn knob to select desired cooking temperature. The heat on indicator will go out when the oven reaches the set temperature, and will cycle on and off as the burners operate to maintain the set cooking temperature.
- 7. Oven Interior Light Switch**
On ovens equipped with an oven interior light, press to turn on the light. The light remains on for as long as the switch is held.
- 8. Power Switch**
Switch ON to use the oven, switch OFF when done using the oven.
- 9. Fuse**

The fan speed can be set to high or low speed by placing the FAN HI/LOW button to the desired setting.

Cooking

A cooking cycle can be initiated as follows:

- Turn the Power Switch.
- Set the Cooking Temperature by turning the TEMPERATURE dial to the desired temperature. The OVEN READY indicator light will turn on.
- When the OVEN READY indicator light turns off, place the product to be cooked in the oven.
- Set the cooking Time by turning the COOK TIMER dial to the desired time.

NOTE: To set times of less than 25 minutes, turn timer Knob past 25 minutes and then back to the desired time.

During the Cook Cycle, the OVEN READY Indicator light will cycle on and off with the heating elements.

- When the COOKTIMER reaches “zero”, the alarm will sound.
- To cancel the alarm, turn the COOK TIMER dial to the OFF position.

B. GENERAL GUIDELINES FOR OPERATION

These guidelines are to assist you in obtaining the best performance from your oven:

- Always pre-heat your oven before cooking by placing the temperature setting at the desired temperature. The oven is pre-heated when the Indicator Light goes out.
- Always use a lower temperature setting than that recommended for a standard convection range oven. The general rule of thumb is to subtract 50 - 100°F from the standard oven recipe. Some experimentation on your part may be necessary to achieve the optimum results with your food products.

Cooking at higher temperatures will not reduce your cooking time! It will produce unsatisfactory baking and roasting results.

- You should begin checking the doneness of your food product in about half the time recommended for the same recipe cooked in a standard oven. There is a Suggested Time and Temperature Chart on the next page, which can serve as a guide. Keep in mind that your times may vary depending on the amount of product being cooked in your oven. The best results are always achieved when a systematic record of times and temperatures is kept for reference.

Do not place an empty sheet pan or aluminum foil on the bottom of the oven. This will disrupt the airflow and cause uneven cooking results.

- To minimize the shrinkage of roasted meats, place the meat directly on the racks and place a sheet pan half full of water in the bottom rack position. The water will keep the oven compartment more humid and less meat juices will evaporate.
- Maintain equal loads when cooking more than one pan of product at a time. You may wish to weigh the product to assure that the pan loads are equal. Smaller loads in one pan will cook at a different rate than larger ones in another.

- You may wish to experiment with leaving the oven OFF after pre-heating the oven and loading when baking light products such as light cake batter or custard so the product will have time to set. Normally, 7-10 minutes with the oven OFF, then finishing with the oven ON, will keep the product from rippling or being pushed by the fan.
- When starting off with frozen product, you may wish to pre-heat your oven up to 100° F above the temperature you are going to cook. Load the product and reset the temperature for the normal time.
- For longer bulb life, do not leave the oven lights on when not viewing the product.

OPERATION INSTRUCTIONS

The information in this section is intended for the use of qualified operating personnel. Qualified Operating Personnel are those individuals who have carefully read the information contained in this manual, are familiar with the function of the oven and/or have had experience with operating the equipment described. We recommend following these instructions to insure optimum performance, long life and trouble-free service from your oven.

6/13 Electric Convection Ovens

Convection cooking has been around from the 1960s. Its advantages are well known. It differs from conventional cooking by the movement of heated air within the cooking cavity by means of a fan. This moving, heated air helps to strip the cool air from around the product being cooked, allowing the heat to penetrate more rapidly. The results are that your product is cooked quicker and at a lower temperature with the comparable product quality found in conventional ovens.

Please take the time to carefully read the operating instructions. They are important in the successful use of your oven.

▲ WARNING The SRCO-E Convection Ovens rely on electricity for powering the ignition system and the fan. Do not attempt to operate during a power failure.

C. SUGGESTED TIMES & TEMPERATURES

	PRODUCT	° F	° C	COOK TIME	RACKS	TEMP	TIME	
BEEF	HAMBURGER PATTIES (3.3 OZ)	400	205	8 - 10 MIN	13			
	MEAT LOAF	325	165	40 -45 MINE	4			
	STEAMSHIP ROUND (80 LBS QUART)	275	135	2 ¼ HOURS	2			
	ROLLED BEEF ROAST (12 - 15 LBS)	275	135	2 ½ HOURS	4			
	STANDING RIB ROAST (20 LBS RARE)	235	115	2 ¾ HOURS	2			
	SHELL STEAKS (10 OZ)	450	230	7 - 8 MIN.	6			
	POT PIES	400	205	30 - 35 MIN.	6			
	STUFFED PEPPERS	350	175	15 - 20 MIN.	4			
	LASAGNA	260	175	90 MIN	4			
	HOT DOGS	325	165	10 - 15 MIN	6			
PORK	BAKED STUFFED PORK CHOPS	375	190	25 - 30 MIN	6			
	BACON	400	205	5 - 7 MIN	13			
VEAL	BONED VEAL ROAST (15 LBS)	300	150	3 HRS 10 MIN	3			
LAMB	LAMB CHOPS	400	205	7 - 8 MIN	6			
POULTRY	CHICKEN BREASTS AND THIGHS	350	175	40 MIN	6			
	CHICKEN BACKS AND WINGS	350	175	35 MIN	6			
	CHICKEN QUARTERED	350	175	30 MIN	6			
	TURKEY ROLL (18 LBS)	310	155	30 - 35 MIN	6			
FISH	FISH STICKS	335	170	16 - 18 MIN	13			
SEAFOOD	COD, HALIBUT (FROZEN)	350	175	20 MIN	6			
	SHRIMP, BAKED STUFFED	400	205	6 - 7 MIN	6			
	LOBSTER, BAKED STUFFED	400	205	10 MIN	4			
	LOBSTER TAILS (FROZEN)	425	220	9 MIN	6			
CHEESE	MACARONI & CHEESE CASSEROLE	350	175	30 MIN	6			
	GRILLED CHEESE SANDWICHES	400	205	8 MIN	13			
POTATOES	BAKED POTATOES	400	205	50 MIN	6			
	SLICED OR DICED POTATOES	325	165	10 MIN	6			
	FRENCH FRIES (FROZEN)	TIMES AND TEMPS WILL VARY AS TO CUT.						
PIES	FROZEN BERRY PIES (22 TO 36 OZ EA)	325	165	35 MIN	6			
	FROZEN FRUIT PIES (24 TO 46 OZ EA)	325	165	45 - 50 MIN	6			
	FRESH APPLE PIE (20 TO 36 OZ EA)	350	175	25 - 30 MIN	6			
	PUMPKIN PIE	300	150	30 - 50 MIN	6			
	FRUIT CRISP	300	150	25 MIN	6			
	FRUIT COBBLER	300	150	30 MIN	6			
	APPLE TURNOVERS	350	175	15 MIN	6			
	BREADS	BREAD (32 - 1 LB LOAVES)	325	165	30 MIN	4		
NORTHERN CORN BREAD		325	165	25 MIN	6			
SOUTHERN CORN BREAD		375	190	15 - 20 MIN	6			
HAMBURGER ROLLS		275	125	15 MIN	6			
	YEAST ROLLS	300	150	25 MIN	6			
	BISCUITS	400	205	6 MIN	6			
	ROLLS, BROWN & SERVE	350	175	15 MIN	6			
CAKES	SHEET CAKE (5 LBS BATTER PER PAN)	325	165	16 - 18 MIN	6			
COOKIES	CHOCOLATE CAKE	325	165	29 MIN	6			
	BROWNIES	325	165	15 MIN	6			
	DANISH PASTRY	325	165	12 MIN	6			
	CINNAMON BUNS	325	165	20 MIN	6			
	SUGAR COOKIES	275	125	15 MIN	13			
	CREAM PUFFS	325	165	20 - 25 MIN	6			
	CHOCOLATE CHIP COOKIES	325	165	10 MIN	13			
		PEANUT BUTTER COOKIES	300	150	10 MIN	13		

NOTE: Your times and temperatures may vary from those shown on this chart. Your results depend on weight per pan, temperature of the product before loading, the recipe, type of pan, and calibration of the thermostat. If your recipes vary from these, write in your proven times and temperatures for your future use.

D. COOK & HOLD/ROAST & HOLD RECOMMENDED TIME & TEMPERATURE

PRODUCT	QTY	COOK TEMP	HOLD TEMP	COOK TIME	HOLD TIME MINIMUM	TOTAL TIME
PRIME RIB BONE IN CAP OFF 14 - 18 LBS (6.4 - 8.1 KG)	1 3 6	200° F 93° C	140° F 60° C	3 HRS 3-1/4 HRS 3-1/2 HRS	1 HR 1-1/2 HRS 2 HRS	4 HR 4-3/4 HRS 5-1/2 HRS
PRIME RIB BONE IN CAP ON 18 - 22 LBS (8.1 - 10 KG)	1 3 6	200° F 93° C	140° F 60° C	3-1/2 HRS 4 HRS 4-1/2 HRS	1 HR 1-1/2 HRS 2 HRS	4-1/2 HRS 5-1/2 HRS 6-1/2 HRS
TOP OR BOTTOM ROUNDS 10 - 12 LBS (4.5 - 5.4 KG)	1 3 6	200° F 93° C	140° F 60° C	3-1/2 HRS 4 HRS 4-1/2 HRS	1 HR 1-1/2 HRS 2 HRS	4-1/2 HRS 5-1/2 HRS 6-1/2 HRS
PORK ROAST OR HAM CAP OFF 10 - 12 LBS (4.5 - 5.4 KG)	1 3 6	250° F 121° C	170° F 76° C	4 HRS 4-1/4 HRS 4-1/2 HRS	1 HR 1-1/2 HRS 2 HRS	5 HR 5-3/4 HRS 6-1/2 HRS
TURKEY 20 - 22 LBS (6.4 - 8.1 KG)	1 2	250° F 121° C	170° F 76° C	3-3/4 HRS 4 HRS	1 HR 1-1/2 HRS	4-3/4 HR 5-1/2 HRS
LEG OF LAMB BONE IN 8 - 10 LBS	2 4 6	225° F 107° C	160° F 71° C	2-1/2 HRS 2-3/4 HRS 3 HRS	1 HR 1-1/2 HRS 2 HRS	3-1/2 HR 4-1/4 HRS 5 HRS

MAINTENANCE INSTRUCTIONS

These maintenance instructions are for the use of qualified service personnel only. Service by other than qualified personnel may result in damage to the oven and/or injury to the operator.

Qualified service personnel are those individuals, firms, Companies or corporations which are engaged in and responsible for repair or servicing of commercial food preparation equipment, who are experienced in such work, familiar with all precautions required, and have complied with all requirements of state and local authorities having jurisdiction.

If you should require assistance in the selection of a qualified service agency, please contact SIERRA Manufacturing Co.'s Service Department at 888-275-4538

A. ADJUSTMENTS

Some functions, which are attributed to defects, may be repaired by adjusting certain parts rather than replacing them.

D. THERMOSTAT CALIBRATION

Electro-Mechanical Controls Only

In many convection ovens thermostats have been the cause of more operating problems than any other component part. Thermostats, being mechanical devices, do sometimes fail, in which case only replacing the part will correct the problem. However, the great majority of

Installation and Operation of Electric Convection Oven

thermostat related problems could be attributed to their being out of adjustment (calibration). A thermostat that is out of calibration may cause unsatisfactory cooking results such as uneven baking, prolonged cooking times, etc. If you are experiencing uneven cooking, it may be a result of excessive cooking temperatures. Refer to the cooking chart provided in Operating Instructions Section C.

To Check Calibration:

- Turn the oven on by turning the Power Switch to the ON position.
- Open the doors and place a thermocouple in the center of the middle oven rack. A reliable mercury-type thermometer can be substituted if a pyrometer is not available.
- Turn the thermostat dial to 350°F (177°C). Allow the oven to preheat 1/2 hour.
- When the indicator light goes out, the thermostat has been satisfied. Check the pyrometer or thermometer to determine the internal oven temperature.
- If the reading on the pyrometer (or thermometer) is less than 10°F different from the setting of the thermostat, no adjustment is needed. If this reading is more than 10°F, proceed with calibration procedure.

To Calibrate the Ovens

- Remove the thermostat knob by loosening the setscrew and pull the knob forward. Take care not to rotate the thermostat stem, which will change the setting.
- With a very small screwdriver, turn the screw located in the bottom of the hollow of the stem clockwise to lower the temperature or counterclockwise to raise the temperature. DO NOT allow the stem of the thermostat to rotate as you turn the screw.
- Open the door and turn the POWER SWITCH to the COOL DOWN position. This will allow the oven fan to come on without the burners and cool off the oven. Allow the oven to cool to about 250°F (120°C).
- Return the POWER SWITCH to the ON position and Repeat the previous steps until the oven thermostat and the pyrometer (thermometer) reading agree.
- Replace the knob and tighten the setscrews.

NOTICE: Maximum turn of screw "A" is 1-1/2 turns—clockwise or counter-clockwise.

This thermostat is a direct-acting (opens on temperature rise) device.

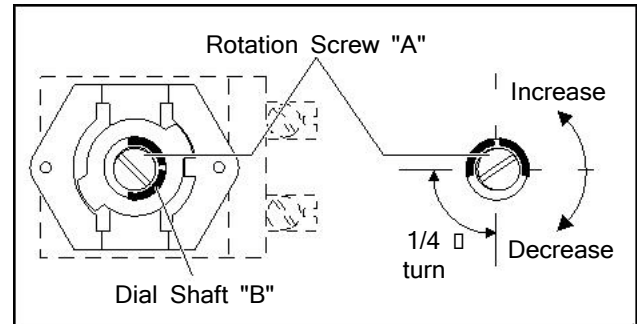

E. CLEANING OF THE OVENS

The stainless steel on your oven can be kept clean with a good stainless steel cleaner, many of which are on the market. The painted surfaces should be wiped clean regularly with a MILD detergent. Moisten a cloth and wipe down the oven while it is COLD. Wiping down an oven while it is hot will cause streaking and otherwise unsatisfactory results. Once the oven is clean it can be wiped down with light oil.

Porcelain oven interiors should be cleaned regularly using a degreasing agent. For heavier deposits a commercial oven cleaner such as Dow Oven Cleaner, Easy-Off, or Mr. Muscle can be used. Care must be taken to prevent these alkaline-type cleaners from coming in contact with any aluminized steel surfaces in the oven, including the blower wheel.

The blower wheel, racks and rack supports can be removed and soaked in a solution of ammonia and water.

Make certain that all parts are thoroughly rinsed before returning to use.

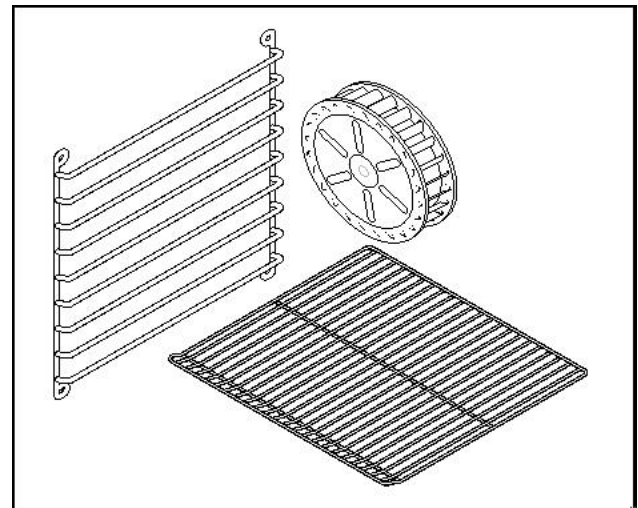

CONTACTOR IDENTIFICATION

