

# Holding Cabinet

Companion to AR-7T Rotisserie Oven

AR-7HT



**MN-48134-EN**

REV 1  
1/23  
**EN**

For the most current manual, visit [alto-shaam.com](http://alto-shaam.com)  
Die neueste Fassung des Handbuchs finden Sie auf [alto-shaam.com](http://alto-shaam.com)  
Pour la dernière version du manuel, visitez [alto-shaam.com](http://alto-shaam.com)  
Para obtener el manual más actual, visite [alto-shaam.com](http://alto-shaam.com)  
Ga voor de meest recente handleiding naar [alto-shaam.com](http://alto-shaam.com)  
За самой последней версией руководства обращайтесь на сайт [alto-shaam.com](http://alto-shaam.com)  
要查看当前最新手册，请访问 [alto-shaam.com](http://alto-shaam.com)



# Manufacturer's Information

---

**Copyright**

© Copyright 1/23 by Alto-Shaam, Inc.

All rights reserved.

This manual or any portion thereof may not be reproduced or used in any manner whatsoever without the express written permission of Alto-Shaam, Inc.

---

**Trademarks**

All trademarks referenced in this documentation are the property of their respective owners.

---

**Manufacturer**

Alto-Shaam, Inc.

P.O. Box 450

W164 N9221 Water Street

Menomonee Falls, WI 53052

---

**Original instructions**

The content in this manual is written in American English.

## Enjoy your Alto-Shaam Holding Cabinet!

---

### Halo Heat

Halo Heat® technology provides a controlled, uniform heat source within the food holding cabinet that maintains precise temperatures throughout the holding process.

The AR-7HT is easy to operate with adjustable, electronic temperature controls. It includes adjustable thermostat and holding temperature gauge to monitor inside air temperature and clear, easy-to-read LED display.

Pass-through option available to allows access to the holding cabinet chamber from both sides for easy restocking and grab-and-go convenience.

Visually appealing with the attractive, front-of-house design to entice customers. Choose from a flat or curved glass door and three different color choices.

## Extend Your Manufacturer's Warranty

---

### Register

Register your Alto-Shaam appliance online. Registering your appliance ensures prompt service in the event of a warranty claim.

Your personal information will not be shared with any other company.

[alto-shaam.com/warranty](http://alto-shaam.com/warranty)

## Alto-Shaam 24/7 Emergency Repair Service

---

### Call

Call 800-558-8744 to reach our 24-hour emergency service call center for immediate access to local authorized service agencies outside standard business hours. The emergency service access is provided exclusively for Alto-Shaam equipment and is available throughout the United States through Alto-Shaam's toll free number.

### Availability

Emergency service access is available seven days a week, including holidays.

This page is intentionally left blank.

This page is intentionally left blank.

Manufacturer’s Information . . . . . 2

**Foreword** . . . . . 3

    Enjoy your Alto-Shaam Holding Cabinet! . . . . . 3

    Extend Your Manufacturer’s Warranty . . . . . 3

    Alto-Shaam 24/7 Emergency Repair Service . . . . . 3

**Table of Contents** . . . . . 5

**Safety** . . . . . 7

    The Meaning of Signal Words . . . . . 7

    Appliance Description and Intended Use. . . . . 8

    Safety Precautions. . . . . 9

**Labels** . . . . . 13

    Label Locations . . . . . 13

**Installation** . . . . . 17

    Dimension Drawing . . . . . 17

    Specifications . . . . . 18

    How to Receive the Appliance . . . . . 19

    How to Unpack the Appliance . . . . . 20

    How to Connect the Appliance to the Floor . . . . . 21

**Operation** . . . . . 23

    How to Turn On and Turn Off the Holding Cabinet . . . . . 23

    How to Operate the Holding Cabinet . . . . . 24

    How to Change the Temperature Scale. . . . . 25

**Maintenance** . . . . . 27

    Maintenance Schedule . . . . . 27

    How to Clean the Door Gasket and Glass . . . . . 28

**Troubleshooting** . . . . . 29

    Error Codes. . . . . 29

**Warranty** . . . . . 31

    Warranty . . . . . 31

# TABLE OF CONTENTS

This page is intentionally left blank.

# The Meaning of Signal Words

This manual contains signal words where needed. These signal words must be obeyed to reduce the risk of death, personal injury, or equipment damage. The meaning of these signal words is explained below.

**DANGER**

Danger indicates a hazardous situation which, if not avoided, will result in serious injury or death.

**WARNING**

Warning indicates a hazardous situation which, if not avoided, could result in serious injury or death.

**CAUTION**

Caution indicates a hazardous situation which, if not avoided, could result in minor or moderate injury.

**NOTICE**

Notice indicates a situation which, if not avoided, could result in property damage.



**NOTE:** Note indicates additional information that is important to a concept or procedure.

# Appliance Description and Intended Use

---

**Appliance Description**

This Alto-Shaam holding cabinet is an electric-powered appliance with electronic control which may be purchased with one or two doors in flat glass or curved glass configurations. It is available with adjustable legs, flanged legs, rubber feet, or casters.

---

**Intended use**

This appliance is intended to hold hot food items for the purpose of human consumption. No other use for this appliance is authorized. This appliance is intended to be used for commercial applications, for example in kitchens of restaurants, canteens, hospitals and in commercial enterprises such as bakeries, butcheries, etc., but not for continuous mass production of food.

---

**Residual risks**

This appliance is manufactured using ISO-certified processes. The appliance is designed with maximum safety in mind; however, there are residual risks to operators of this appliance. Residual risks include exposure to heat and exposure to hot food products.

---

**Possible misuse**

Misuse of this appliance includes holding food containing flammable materials (such as food with alcohol). Substances with a low flash point can ignite spontaneously and cause a fire.



# Safety Precautions

---

## Before you begin

Read and understand all instructions in this manual.

---

## Electrical precautions

Obey these electrical precautions when using the appliance:

- Various electrical configurations of the appliance are available. Always match the power source with the power rating on the appliance's data tag.
  - Use one (1) dedicated circuit per appliance.
  - The main disconnection device of this appliance is the cord with plug.
  - Keep the cord away from hot surfaces.
  - Electrical connections and circuit breakers must meet all applicable federal, state and local codes.
  - Do not let the cord hang over the edge of a table or counter.
- 

## Usage precautions

Obey these usage precautions when using the appliance:

- Only use this appliance for its intended use of holding hot food.
  - Do not load liquids, or foods that can become liquid when heated, into the appliance.
  - Use utensils and protective clothing when loading and unloading the appliance.
  - Use caution when using the appliance. Floors adjacent to the appliance may become slippery.
  - Use caution when opening the appliance door. Escaping hot vapors or steam can cause serious injury.
  - Do not cover or block any of the openings of this appliance.
  - Do not use this appliance near water such as a sink, in a wet location, near a swimming pool, or similar locations.
- 

## Maintenance precautions

Obey these maintenance precautions when maintaining the appliance:

- Obey precautions in the manual, on tags, and on labels attached to or shipped with the appliance.
- The appliance must be cleaned thoroughly to prevent deposits of grease and food residue inside the appliance that may catch fire.
- Do not place combustible materials in the appliance.
- Do not store the appliance outdoors.
- Do not clean the appliance with metal scouring pads.
- Do not use a water jet or steam cleaner to clean the appliance.
- Do not store or use any flammable substances near the appliance.
- For users only: Do not remove the top cover or side panels. There are no user-serviceable components inside.

**Caster precautions**

Obey these precautions if the appliance is installed on casters.

- Restrict movement of the appliance with a tether so that utility connections (water and electricity) are not damaged.
  - Disconnect all utility connections when moving the appliance.
  - Only use this appliance when it is stationary.
  - Use caution when using the appliance on uneven floors. Mobile appliances and accessories can roll or tip over and cause serious injury or property damage.
  - Lock the caster brakes on mobile appliances or accessories when they are not being moved.
- 

**Operator training**

All personnel using the appliance must have proper operator training. Before using the appliance:

- Read and understand the operating instructions contained in all the documentation delivered with the appliance.
  - Know the location and proper use of all controls.
  - Keep this manual and all supplied instructions, diagrams, schematics, parts lists, notices, and labels with the appliance if the appliance is sold or moved to another location.
  - Contact Alto-Shaam for additional training if needed.
- 

**Operator qualifications**

Only trained personnel with the following operator qualifications are permitted to use the appliance:

- Have received proper instruction on how to use the appliance.
- Have demonstrated their ability with commercial kitchens and commercial appliances.

The appliance must not be used by:

- Persons (including children) with reduced physical, sensory or mental capabilities, or lack of experience and knowledge, unless they have been given supervision concerning use of the appliance by person responsible for their safety.
  - People impaired by drugs or alcohol.
- 

- Children should be supervised to ensure that they do not play with the appliance.
  - Children shall neither clean nor maintain the appliance.
- 

**Condition of appliance**

Only use the appliance when:

- All controls operate correctly.
- The appliance is installed correctly.
- The appliance is clean.
- The appliance labels are legible.

### **Servicing the appliance**

- Only trained personnel are permitted to service or repair the appliance. Repairs performed by unauthorized service partners or untrained technicians, or the use of parts that do not meet factory specifications, will void the warranty and relieve Alto-Shaam of all liability.
  - To prevent serious injury, death or property damage, have the appliance inspected and serviced at least every twelve (12) months by an authorized service partner or trained technician.
  - If a power cord must be replaced, an oil resistant cord like H05RN or H07RN or equivalent must be used.
  - Contact Alto-Shaam for the authorized service partner in your area.
- 

### **Personal Protective Equipment (PPE)**

Wear the following Personal Protective Equipment (PPE) while cleaning the appliance:





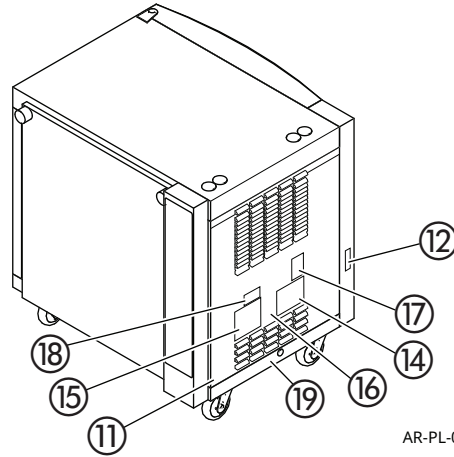
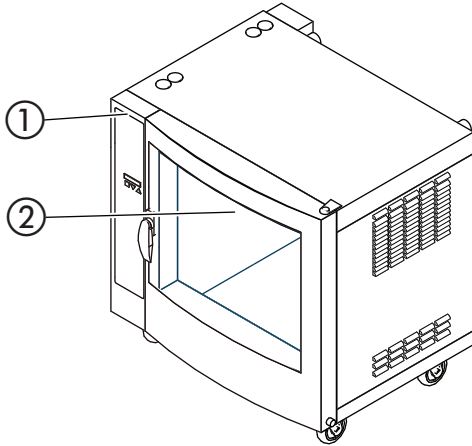

- Protective gloves
- Protective clothing
- Eye protection
- Face protection



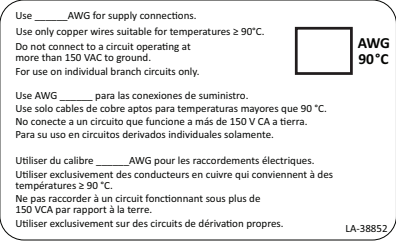

This page is intentionally left blank.

# Label Locations

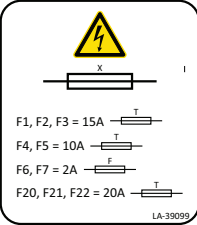

AR-PL-015450

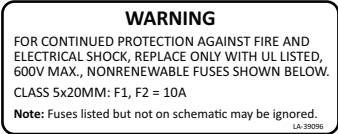
|     |   |   |
|-----|---|---|
| 1   |    | Made in U.S.A.  |
| 2   |    | <p>WARNING</p> <p>Hot surface</p>   |
| --- | ---   | ---   |
| 11  |    | <p>Every Alto-Shaam product is precision calibrated prior to release from the factory to ensure accurate temperature control.</p>   |
| 12  |   | Security seal   |
| 13  |  | <p><b>Note:</b> <i>This label is only used on UL-certified appliances that have 120V to ground wiring.</i></p> <p>Use _____ AWG for supply connections.</p> <p>Use only copper wires suitable for temperature less than or equal to 90°C.</p> <p>Do not connect to a circuit operating at more than 150 VAC to ground.</p> <p>For use on individual branch circuits only.</p> |
| 14  |  | <p>WARNING</p> <p>Electric Shock Hazard</p> <p>To reduce the risk of electric shock, do not remove or open cover. No user-serviceable parts inside. Refer servicing to qualified personnel.</p> <p>Qualified personnel: Disconnect power before servicing.</p>  |

|    |   |   |
|----|---|---|
| 15 | ---   | ---   |
| 16 |    | <p><b>WARNING</b><br/>Electric Shock Hazard</p> <p>Use the correct fuse of the specified type, current, and voltage rating.</p>   |
| 17 |    | <p>Oven light: 12V, 20W max.</p>  |
| 18 |    | <p><b>WARNING.</b> For continued protection against fire and electrical shock, replace only with UL listed 600V max., nonrenewable fuses shown below.</p> <p>Class 5x20mm: F1, F2 =10A</p> <p>Note: Fuses listed but not on schematic may be ignored.</p> |
| 19 |  | <p>Equipotential stud</p>   |
|    |  | <p>Consult instructions for operation and use.</p>  |

This page is intentionally left blank.



# Dimension Drawing

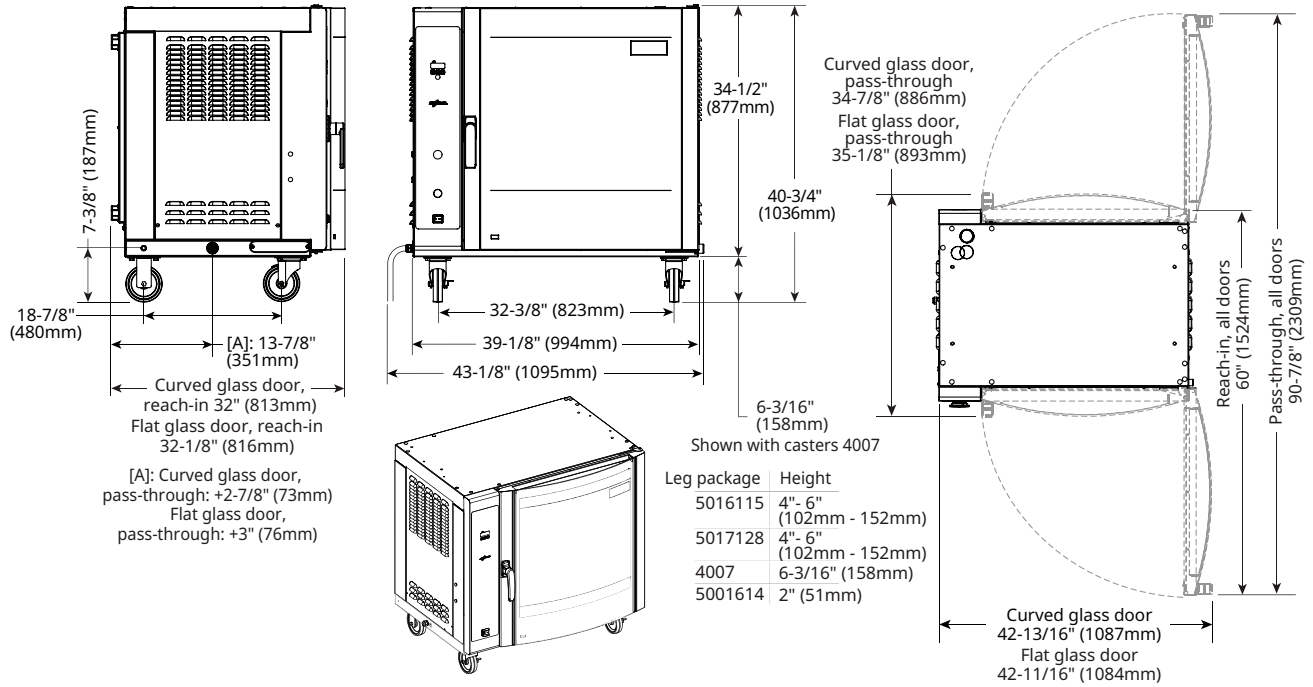

AR-DIM-015453

INSTALLATION

# Specifications

## Capacity



PANS

**8** Eight (8) full-size sheets 18" x 26" x 1" [457mm x 660mm x 25mm]\*

**16** Sixteen half-size sheets 18" x 13" x 1" [457mm x 330mm x 25mm]\*

\* With additional wire shelves



BOATS

**24** Chicken boats; six (6) per shelf



FOOD

**98** 98 lb [44 kg] of cooked food



CHECK FIRST

- The holding companion must be installed level.
- The holding companion must not be installed in any area where it may be affected by steam, grease, dripping water, high temperatures, or any other severely adverse conditions.
- In order to maintain NSF standards, the unit must be sealed at bottom by NSF approved sealant, or equipped with legs/casters.



CLEARANCE

**Left** 6" [152mm]  
**Right** 6" [152mm]  
**Back** 6" [152mm]  
**Top** 0" [0mm]



DIMENSIONS

### Model

AR-7HT, Curved glass, solid back [reach-in]  
 AR-7HT, Curved glass, pass-through  
 AR-7HT, Flat glass, solid back [reach-in]  
 AR-7HT, Flat glass, pass-through

### Exterior (H x W x D)

40-3/4" x 43-1/8" x 32" [1035mm x 1095mm x 813mm]  
 40-3/4" x 43-1/8" x 34-7/8" [1035mm x 1095mm x 886mm]  
 40-3/4" x 43-1/8" x 32-1/8" [1035mm x 1095mm x 816mm]  
 40-3/4" x 43-1/8" x 35-1/8" [1035mm x 1095mm x 892mm]

### Net Weight

321 lb [146kg]  
 321 lb [146kg]  
 321 lb [146kg]  
 321 lb [146kg]

### Ship Dimensions (L x W x H)\*

AR-7HT 56" x 45" x 51" [1422mm x 1143mm x 1295mm]

### Ship Weight\*

400 lb [181 kg]

\*Domestic ground shipping information. Contact factory for export weight and dimensions.



ELECTRIC

| V       | Ph | Hz    | A       | Breaker | kW      | Plug Configuration          | Cord Length   |
|---------|----|-------|---------|---------|---------|-----------------------------|---------------|
| 120     | 1  | 60    | 12.9    | 15      | 1.5     | NEMA 5-20P 20A, 125V        | 72" [1829mm]  |
| 208-240 | 1  | 60    | 5.5-6.4 | 15      | 1.1-1.5 | NEMA 6-15P 15A, 250V        | 108" [2743mm] |
| 230     | 1  | 50/60 | 6.1     | 15      | 1.4     | CEE 7/7 250V   CH2-16P 250V | 108" [2743mm] |

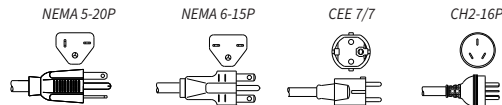

# How to Receive the Appliance

## Responsible parties

When an Alto-Shaam® preferred carrier is used, shipping damage is a matter between Alto-Shaam and the carrier. In such cases, contact Alto-Shaam customer service.

When an Alto-Shaam non-preferred carrier is used, shipping damage is a matter between the carrier and the consignee. In such cases, the carrier is assumed to be responsible for the safe delivery of the merchandise, unless negligence can be established on part of the shipper.

## Receive the appliance

When receiving the appliance, do the following.

| Step | Action  |
|------|---|
| 1.   | <b>Inspect</b> the equipment while it is still in the truck or immediately after it is moved to the receiving area. Do not wait until after the equipment is moved to a storage area. |
| 2.   | <b>Inspect and count</b> all merchandise received. Do not sign a delivery receipt or a freight bill until you have done so.   |
| 3.   | <b>Note</b> all damage to packaging and to the equipment on the carrier's receipt.  |
| 4.   | <b>Request</b> the driver sign the delivery receipt. If the driver refuses to sign, make a note of this refusal on the delivery receipt.  |
| 5.   | <b>Write</b> the following on the delivery receipt if the driver refuses to allow an inspection: Driver refuses to allow inspection of containers for visible damage.                 |
| 6.   | <b>Contact</b> the carrier immediately upon finding damage, and request an inspection. <b>Follow</b> the carrier's policies and procedures.   |

## Alto-Shaam policy

It is the policy of Alto-Shaam to assist customers in collecting claims that have been properly filed and actively pursued. Alto-Shaam cannot, however, file damage claims, assume the responsibilities for damage claims, or accept deductions in payment for damage claims.

# How to Unpack the Appliance

## Before you begin

### Make sure you have:

- An appropriate lifting device and enough personnel to safely move and position the weight of the oven.
  - AR-7HT shipping weight: 400 lb (181kg)
  - AR-7HT net weight: 321 lb (146kg)
- Cutting tools to remove the packaging.

## Unpack the appliance

To unpack the appliance, do the following.

| Step  | Action   |
|---|--|
| 1.  | <b>Remove</b> banding before lifting the appliance. Only lift the appliance from the front.  |
| 2.  | <b>Remove</b> the appliance from the carton or crate. <b>Save</b> all packing materials for inspection by the carrier.   |
| <div style="border: 1px solid gray; padding: 10px;"> <p> <b>NOTE:</b> Examine the appliance for damage. If the appliance has been damaged, do not use the appliance until it has been inspected by an authorized service provider. Contact your carrier or Alto-Shaam customer service.</p> </div> |  |
| 3.  | <b>Remove</b> all protective film, packaging materials, and items from inside the appliance.   |
| 4.  | <b>Clean</b> the interior and exterior of the appliance with a mild soap and water solution. Remove any detergent residue with a clean, damp cloth. Dry with a clean, lint-free cloth. |
| 5.  | <b>Clean</b> the appliance glass with glass cleaner or distilled vinegar.  |

## Clean the appliance

## Result

The appliance is now unpacked.

# How to Connect the Appliance to the Floor

## Before you begin

- Make sure the appliance has the appropriate flanged feet which allow connecting to the floor.
- Make sure you have an appropriate lifting device to lift the weight of the appliance
- Make sure you have the appropriate tools and fasteners to connect the appliance to the floor.

## Procedure

To connect the appliance to the floor, do the following.

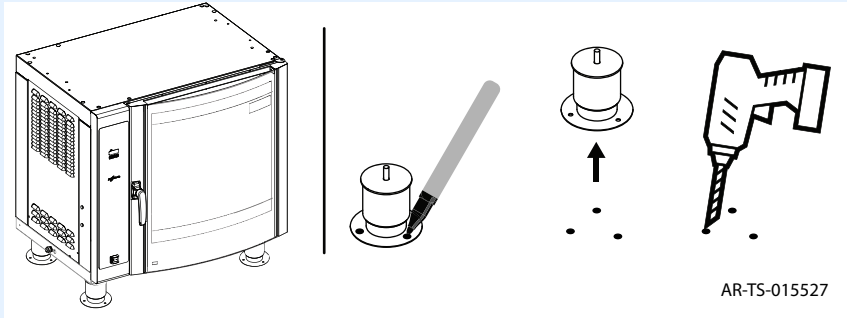
| Step | Action   |
|------|--|
| 1.   | <b>Make sure</b> the power cord is not connected to the power source.  |
| 2.   | <b>Set</b> the appliance in its operating position.  |
| 3.   | <b>Make sure</b> the appliance is level.   |
| 4.   | <p><b>Make</b> marks on the floor to identify the holes of each foot flange.</p>  <p style="text-align: right;">AR-TS-015527</p> <p><b>Move</b> the appliance to allow room to drill.<br/><b>Drill</b> holes to fit your fasteners.</p> |
| 5.   | <b>Align</b> the appliance over the holes.   |
| 6.   | <b>Connect</b> the appliance to the floor with the fasteners.  |

## Result

The appliance is now connected to the floor.

This page is intentionally left blank.

# How to Turn On and Turn Off the Holding Cabinet

## Before you begin

The holding cabinet must be connected to electric power.

## Turning on the holding cabinet

To turn on the holding cabinet, do the following.

| Step | Action |
|------|--------|
|------|--------|

1. **Set** the power switch to the ON (I) position ①.

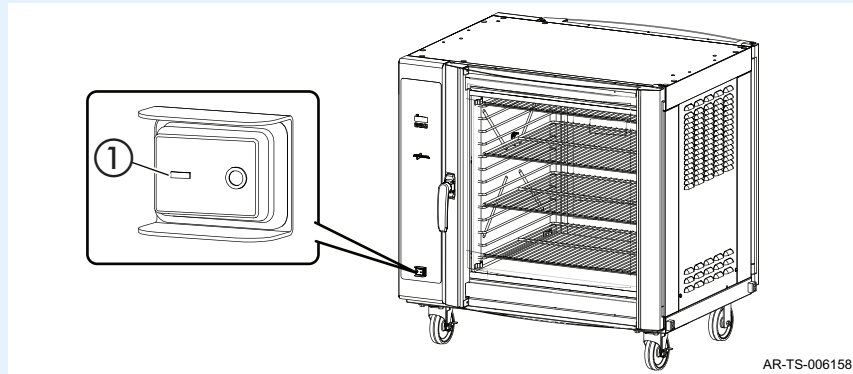

The holding cabinet is now on.

## Turning off the holding cabinet

To turn off the holding cabinet, do the following.

| Step | Action |
|------|--------|
|------|--------|

1. **Set** the power switch to the OFF (0) position.

The holding cabinet is now off.

# How to Operate the Holding Cabinet

## Before you begin

The holding cabinet must be connected to electric power and turned on.

## Procedure

To operate the holding cabinet, do the following.

| Step  | Action   |
|---|--|
| 1.  | <b>Set</b> the temperature using the arrow buttons ①.                                    |
| <p><b>NOTE:</b> The temperature set-point range is 60°F – 200°F (16°C – 93°C)</p>  <p><b>Press and hold</b> the arrow button to change degree intervals by ten (10) degrees.</p> |  |
| 2.  | <b>Press and hold</b> the temperature recall button ② to display the actual temperature. |

1. **Set** the temperature using the arrow buttons ①.

**NOTE:** The temperature set-point range is 60°F – 200°F (16°C – 93°C)

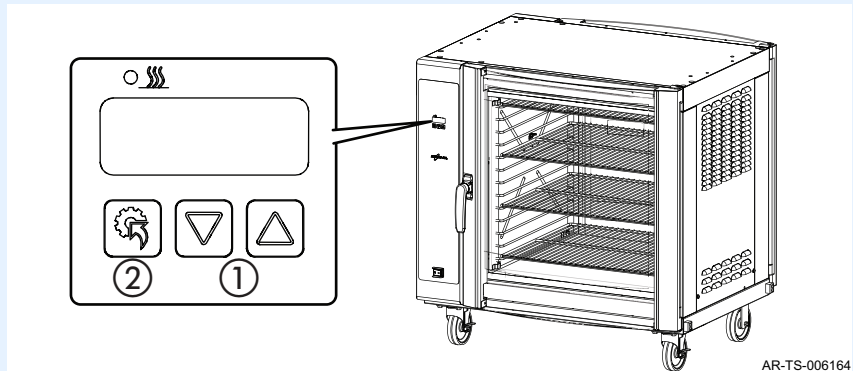

AR-TS-006164

**Press and hold** the arrow button to change degree intervals by ten (10) degrees.

## Displaying the temperature

2. **Press and hold** the temperature recall button ② to display the actual temperature.

## Result

The holding cabinet is now ready for holding food.



# How to Change the Temperature Scale

## Procedure

To change the temperature scale from °F to °C and vice versa, do the following.

| Step | Action   |
|------|--|
| 1.   | <b>Press and hold</b> the temperature recall button ① and down arrow button ② at the same time for five (5) seconds. |



**NOTE:** The factory default temperature scale is set to °F.

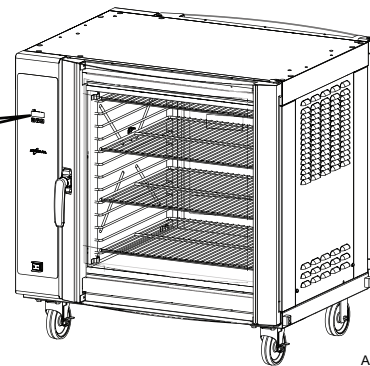
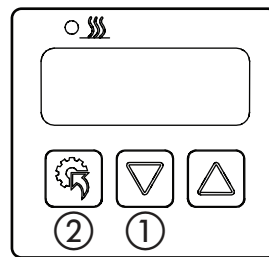

AR-TS-006173

2. **Repeat** the process to change the temperature scale.

## Result

The temperature scale has now been changed.

This page is intentionally left blank.

# Maintenance Schedule

---

## Requirements

- Make sure the oven is under 140°F (60°C) before cleaning.
  - Do not use a hose or water jet on external and technical parts of the appliance.
- 

## Daily

For daily maintenance, do the following.

- **Clean** all grease and debris from the bottom of the appliance.
  - **Clean** the glass and outside of the oven.
  - **Clean** the door gasket.
- 

## Weekly

For weekly maintenance, do the following.

- **Inspect** the door gaskets for tears.
  - **Clean** the outside of the oven with a stainless steel cleaner.
- 

## Monthly

For monthly maintenance, do the following.

- **Inspect** the casters if equipped.
- **Inspect** the controller for damage.

# How to Clean the Door Gasket and Glass

## Before you begin



**WARNING:** Burn hazard.

Wear protective gloves, protective clothing, eye protection, and face protection when handling oven cleaner.

**NOTICE**

Do not use steel pads, wire brushes, or scrapers when cleaning.

**Make sure** you have glass cleaner or distilled vinegar.

## Procedure

To clean the door gasket and glass, do the following.

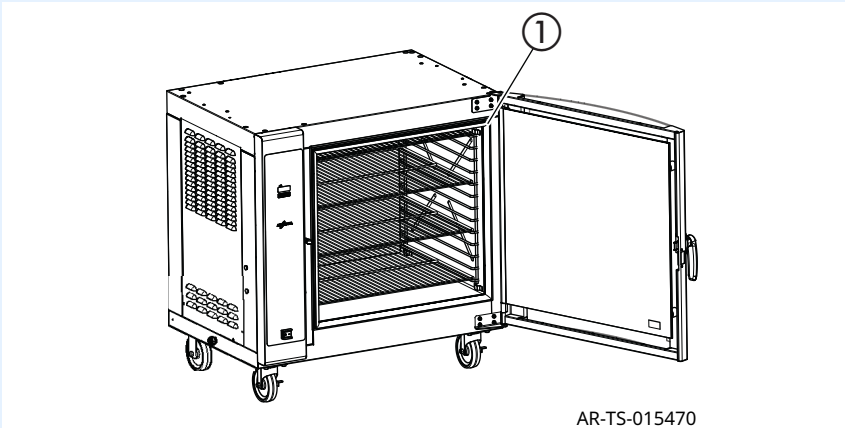
| Step  | Action   |
|---|--|
| 1.  | <b>Make sure</b> the oven is cool—oven is less than 140°F (60°C).                  |
| 2.  | <b>Clean</b> the door gasket ① with soap and water.                                |
|  <p>AR-TS-015470</p> |  |
| 3.  | <b>Clean</b> each side of the window pane with glass cleaner or distilled vinegar. |
| 4.  | <b>Leave</b> the door open until the door gasket completely dries.                 |

## Result

The oven door is now clean.

## Error Codes

| Error Display | Error Description                           | Error Definition Comments                                 | Reset  |
|---------------|---|---|--|
| E-10          | Sensor 0 shorted                            | Sensor short determined                                   | Auto-reset w hen sensor short resolved.                          |
| E-11          | Sensor 0 open                               | Resistance >3000 ohm (sensor not connected)               | Auto-reset w hen good probe is attached, i.e. valid reading      |
| E-30          | Under Temperature                           | 25°F under Set Point Temperature for 90 minutes.          | Auto-reset w hen temp rises above the Under Temp alarm condition |
| E-31          | Over Temperature                            | OVEN: 145°F over max temp range for that model. No delay. | Auto-reset w hen temperature < F over max temp range. 145°       |
| E-38          | Internal software error                     | Internal Software error                                   | Call Factory   |
| E-39          | Sensor Error                                | Board level RTD temp circuit hardware error               | Call Factory   |
| E-70          | Configuration connector error (DIP-sw itch) | Dip-Sw itch error: not set to model or invalid model      | Correct DIP-sw itch. Turn control OFF, then ON.                  |
| E-83          | EEPROM error                                | Bad checksum.   | Reset by performing CALIBRATION.                                 |
| E-90          | Key Shorted                                 | Any key > 1 min shorted                                   | Reset w hen key no longer shorted                                |

This page is intentionally left blank.

# Warranty

## Introduction

Alto-Shaam, Inc. warrants to the original purchaser only, that any original part found to be defective in material or workmanship will be replaced with a new or rebuilt part at Alto-Shaam's option, subject to provisions hereinafter stated.

## Warranty Period

The original parts warranty period is as follows:

- For all other original parts, one (1) year from the date of installation of appliance or fifteen (15) months from the shipping date, whichever occurs first.
- The labor warranty period is one (1) year from the date of installation or fifteen (15) months from the shipping date, whichever occurs first.
- Alto-Shaam will bear normal labor charges performed during standard business hours, excluding overtime, holiday rates or any additional fees.
- For the refrigeration compressor, if installed, the warranty period is five (5) years from the date of original installation of the appliance.
- For heating elements on Halo Heat® Cook and Hold ovens, the warranty period is for as long as the original owner owns the oven. This warranty period applies to units sold after 2/1/2009 and excludes holding-only ovens.
- To be valid, a warranty claim must be asserted during the applicable warranty period. This warranty is not transferable.

## Exclusions

This warranty does not apply to:

- Calibration.
- Replacement of light bulbs, rubber gaskets, grease filters, air filters, racks, jet plates, and/or the replacement of glass due to damage of any kind.
- Equipment damage caused by accident, shipping, improper installation or alteration.
- Equipment used under conditions of abuse, misuse, carelessness or abnormal conditions, including but not limited to, equipment subjected to harsh or inappropriate chemicals, including but not limited to, compounds containing chloride or quaternary salts, poor water quality, or equipment with missing or altered serial numbers.
- Equipment damage caused by use of any cleaning agents other than those recommended by Alto-Shaam, including but not limited to damage due to chlorine or other harmful chemicals.
- Any losses or damage resulting from malfunction, including loss of food product, revenue, or consequential or incidental damages of any kind.
- Equipment modified in any manner from original model, substitution of parts other than factory authorized parts, unauthorized removal of any parts including legs, or unauthorized addition of any parts.

*Continued on next page*

WARRANTY

*Continued from previous page*

- Equipment damage incurred as a direct result of poor water quality\*, inadequate maintenance of steam generators and/or surfaces affected by water. Water quality and required maintenance of steam generating equipment is the responsibility of the owner/operator.
  - Equipment damage incurred as a result of not following the required maintenance schedule published in the manuals for the equipment.
- 

## **Conclusion**

This warranty is exclusive and is in lieu of all other warranties, express or implied, including the implied warranties of merchantability and fitness for a particular purpose. No person except an officer of Alto-Shaam, Inc. is authorized to modify this warranty or to incur on behalf of Alto-Shaam any other obligation or liability in connection with Alto-Shaam equipment.

*\*Refer to the product spec sheet for water quality standards.*







# ALTO-SHAAM.

Menomonee Falls, WI U.S.A.

Phone 800-558-8744 | +1-262-251-3800 | alto-shaam.com

## ASIA

Shanghai, China  
Phone +86-21-6173-0336

## AUSTRALIA

Brisbane, Queensland  
Phone 800-558-8744

## CANADA

Concord, Ontario Canada  
Toll Free Phone 866-577-4484  
Phone +1-905-660-6781

## FRANCE

Aix en Provence, France  
Phone +33(0)4-88-78-21-73

## GMBH

Bochum, Germany  
Phone +49 (0)234 298798-0

## ITALY

Padua, Italy  
Phone +39 3476073504

## INDIA

Pune, India  
Phone +91 9657516999

## MEXICO

Phone +52 1 477-717-3108

## MIDDLE EAST & AFRICA

Dubai, UAE  
Phone +971-4-321-9712

## CENTRAL & SOUTH AMERICA

Miami, FL USA  
Phone +1 954-655-5727

## RUSSIA

Moscow, Russia  
Phone +7 903 7932331