

## Heated Shelf Merchandiser

HSM-24/3S/T

HSM-24/5S/T

HSM-36/2S/T

HSM-36/3S/T

HSM-36/5S/T

HSM-48/5S/T



**MN-47789-EN**

REV.02  
12/22

**EN**

For the most current manual, visit [alto-shaam.com](http://alto-shaam.com)

Die neueste Fassung des Handbuchs finden Sie auf [alto-shaam.com](http://alto-shaam.com)

Pour la dernière version du manuel, visitez [alto-shaam.com](http://alto-shaam.com)

Para obtener el manual más actual, visite [alto-shaam.com](http://alto-shaam.com)

Ga voor de meest recente handleiding naar [alto-shaam.com](http://alto-shaam.com)

За самой последней версией руководства обращайтесь на сайт [alto-shaam.com](http://alto-shaam.com)

要查看当前最新手册，请访问 [alto-shaam.com](http://alto-shaam.com)



# Manufacturer's Information

---

**Copyright**

© Copyright 12/22 by Alto-Shaam, Inc.

All rights reserved.

This manual or any portion thereof may not be reproduced or used in any manner whatsoever without the express written permission of Alto-Shaam, Inc.

---

**Trademarks**

All trademarks referenced in this documentation are the property of their respective owners.

---

**Manufacturer**

Alto-Shaam, Inc.

P.O. Box 450

W164 N9221 Water Street

Menomonee Falls, WI 53052

---

**Original instructions**

The content in this manual is written in American English.

# Enjoy your Alto-Shaam® Heated Shelf Merchandiser!

## Halo Heat® Technology

Alto-Shaam heated shelf merchandisers utilize precise and one-of-a-kind Halo Heat® technology to keep food at the highest quality, heating it from both the top and bottom.

Keep hot-and-ready meals in a display attractive to customers with this customizable merchandiser. Make the appliance your own with LED-lighted shelves, customized branding, backlit interchangeable graphics, pricing rails, and window sides. Display a variety of grab and go products such as rotisserie chickens, sandwiches, and pizza on the merchandiser's evenly-heated shelves.

## Extend Your Manufacturer's Warranty

### Register

Register your Alto-Shaam appliance online. Registering your appliance ensures prompt service in the event of a warranty claim.

Your personal information will not be shared with any other company.

[alto-shaam.com/warranty](http://alto-shaam.com/warranty)

## Alto-Shaam 24/7 Emergency Repair Service

### Call

Call 800-558-8744 to reach our 24-hour emergency service call center for immediate access to local authorized service agencies outside standard business hours. The emergency service access is provided exclusively for Alto-Shaam equipment and is available throughout the United States through Alto-Shaam's toll free number.

### Availability

Emergency service access is available seven days a week, including holidays.

This page is intentionally left blank.

Manufacturer’s Information . . . . . 2

**Foreword** . . . . . 3

    Enjoy your Alto-Shaam® Heated Shelf Merchandiser! . . . . . 3

    Extend Your Manufacturer’s Warranty . . . . . 3

    Alto-Shaam 24/7 Emergency Repair Service . . . . . 3

**Table of Contents** . . . . . 5

**Safety** . . . . . 7

    The Meaning of Signal Words . . . . . 7

    Appliance Description and Intended Use. . . . . 8

    Safety Precautions. . . . . 9

**Labels** . . . . . 13

    Label Locations . . . . . 13

**Installation** . . . . . 17

    Dimension Drawings . . . . . 17

    How to Receive the Appliance . . . . . 23

    How to Unpack the Merchandiser. . . . . 24

    How to Install the Merchandiser . . . . . 26

    How to Install the Merchandiser (Without Cord or Plug). . . . . 31

    How to Install the Skirt on a Floor Model Merchandiser . . . . . 37

    How to Add a Display Base to an Existing Countertop Merchandiser. 38

    How to Install the Optional Shelf Insert for Magnetic Signage Panels 42

**Operation** . . . . . 43

    Shelf Capacities . . . . . 43

    How to Turn On and Turn Off the Merchandiser . . . . . 44

    How to Prepare the Merchandiser for First Use . . . . . 45

    How to Operate the Merchandiser . . . . . 46

**Maintenance** . . . . . 49

    How to Clean the Merchandiser . . . . . 49

**Warranty** . . . . . 51

    Warranty . . . . . 51

**Declaration of Conformity** . . . . . 53

# TABLE OF CONTENTS

This page is intentionally left blank.

# The Meaning of Signal Words

This manual contains signal words where needed. These signal words must be obeyed to reduce the risk of death, personal injury, or equipment damage. The meaning of these signal words is explained below.

**DANGER**

Danger indicates a hazardous situation which, if not avoided, will result in serious injury or death.

**WARNING**

Warning indicates a hazardous situation which, if not avoided, could result in serious injury or death.

**CAUTION**

Caution indicates a hazardous situation which, if not avoided, could result in minor or moderate injury.

**NOTICE**

Notice indicates a situation which, if not avoided, could result in property damage.



**NOTE:** Note indicates additional information that is important to a concept or procedure.

# Appliance Description and Intended Use

---

**Halo Heat Technology®**

Alto-Shaam Halo Heat® provides precise all-around warming, allowing for food to be kept for longer hold times at the highest quality. This gentle heat surrounds the food evenly in the merchandiser via a low-density thermal cable—eliminating the need for fans, added humidity, or hot components.

---

**Nomenclature**

HSM-24/3S/T means Heated Shelf Merchandiser, 24-inch width, three-shelf, and top heat.

---

**Configurations**

Heated Shelf Merchandisers are available in configurations based on the width of the appliance and the number of shelves.

The 24-inch units are available in 3- and 5-shelf configurations.

The 36-inch units are available in 2-, 3-, and 5-shelf configurations.

The 48-inch units are available in a 5-shelf configuration.

---

**Intended use**

Heated Shelf Merchandisers are intended to hold food only. Any other use is prohibited. This appliance is intended to be used for commercial applications, for example in kitchens of restaurants, canteens, hospitals and in commercial enterprises such as bakeries, butcheries, etc., but not for continuous mass production of food.

---

**Residual risks**

This merchandiser is manufactured using ISO-certified processes. The merchandiser is designed with maximum safety in mind; however, there are residual risks to operators of this merchandiser. Residual risks include exposure to heat and exposure to hot food products.

---

**Possible misuse**

Misuse of this merchandiser includes loading the merchandiser with anything other than a food product. Misuse also includes holding any food product that contains alcohol or other flammable substance.

---

**Environmental conditions**

Before use the appliance must acclimate to room temperature in the environment it is installed: 24 hours is recommended.

Ambient temperature range: 60°F to 110°F (16°C to 43°C).

Relative humidity range: less than 95% non-condensation.

Atmospheric pressure range: 15 to 31 in. mercury (50kPa to 106kPa).

---



# Safety Precautions

---

## Before you begin

Read and understand all instructions in this manual.

---

## Electrical precautions

Obey these electrical precautions when using the appliance:

- Connect the appliance to a properly grounded outlet. Do not use the appliance if it is not properly grounded. Consult an electrician if there is any doubt that the outlet used is properly grounded.
  - Keep the cord away from hot surfaces.
  - Do not attempt to service the appliance or its cord and plug.
  - Do not operate the appliance if it has a damaged cord or plug.
  - Do not immerse the cord or plug in water.
  - Do not let the cord hang over the edge of a table or counter.
  - Do not use an extension cord.
- 

## Usage precautions

Obey these usage precautions when using the appliance:

- Only use this appliance for its intended use of holding hot food.
  - Do not cover or block any of the openings of this appliance.
  - Do not cover shelves or any other part of this appliance with metal foil.
  - Do not use this appliance near water such as a sink, in a wet location, near a swimming pool, or similar locations.
  - For units with casters: Unplug unit and allow to cool before moving to a new location.
- 

## Maintenance precautions

Obey these maintenance precautions when maintaining the appliance:

- Obey precautions in the manual, on tags, and on labels attached to or shipped with the appliance.
- Only clean the appliance when it is disconnected from the power source.
- Do not store the appliance outdoors.
- Do not clean the appliance with metal scouring pads.
- Do not use corrosive chemicals when cleaning the appliance.
- Do not use a hose, water jet, or steam cleaner to clean the appliance.
- Do not use the appliance for storage.

*Continued on next page*

*Continued from previous page*

### Operator training

All personnel using the appliance must have proper operator training. Before using the appliance:

- Read and understand the operating instructions contained in all the documentation delivered with the appliance.
- Know the location and proper use of all controls.
- Keep this manual and all supplied instructions, diagrams, schematics, parts lists, notices, and labels with the appliance if the appliance is sold or moved to another location.
- Contact Alto-Shaam for additional training if needed.

### Operator qualifications

Only trained personnel with the following operator qualifications are permitted to use the appliance:

- Have received proper instruction on how to use the appliance.
- Have demonstrated their ability with commercial kitchens and commercial appliances.

The appliance must not be used by:

- Persons (including children) with reduced physical, sensory or mental capabilities, or lack of experience and knowledge, unless they have been given supervision concerning use of the appliance by person responsible for their safety.
- People impaired by drugs or alcohol.

- Children should be supervised to ensure that they do not play with the appliance.
- Children shall neither clean nor maintain the appliance.

### Condition of appliance

Only use the appliance when:

- All controls operate correctly.
- The appliance is installed correctly.
- The appliance is clean.
- The appliance labels are legible.

### Servicing the appliance

- Only trained personnel are permitted to service or repair the appliance. Repairs that are not performed by an authorized service partner or trained technician will void the warranty and relieve Alto-Shaam of all liability.
- To prevent serious injury, death or property damage, have the appliance inspected and serviced at least every twelve (12) months by an authorized service partner or trained technician.
- Contact Alto-Shaam for the authorized service partner in your area.

*Continued on next page*

*Continued from previous page*

### **Personal Protective Equipment (PPE)**

Wear the following Personal Protective Equipment (PPE) while cleaning the appliance:

- Protective gloves
- Protective clothing
- Eye protection
- Face protection

---

### **Use of restraining devices**

A restraining device (tether) must be installed to any appliance that is hard-wired and mounted on casters. The tether must:

- Be secured to the building's structure.
- Limit the movement of the appliance so that no stress is transmitted to the electrical conduit.

A connection point for the tether is located on the back of the appliance.

A tether is not supplied by nor available from the manufacturer.



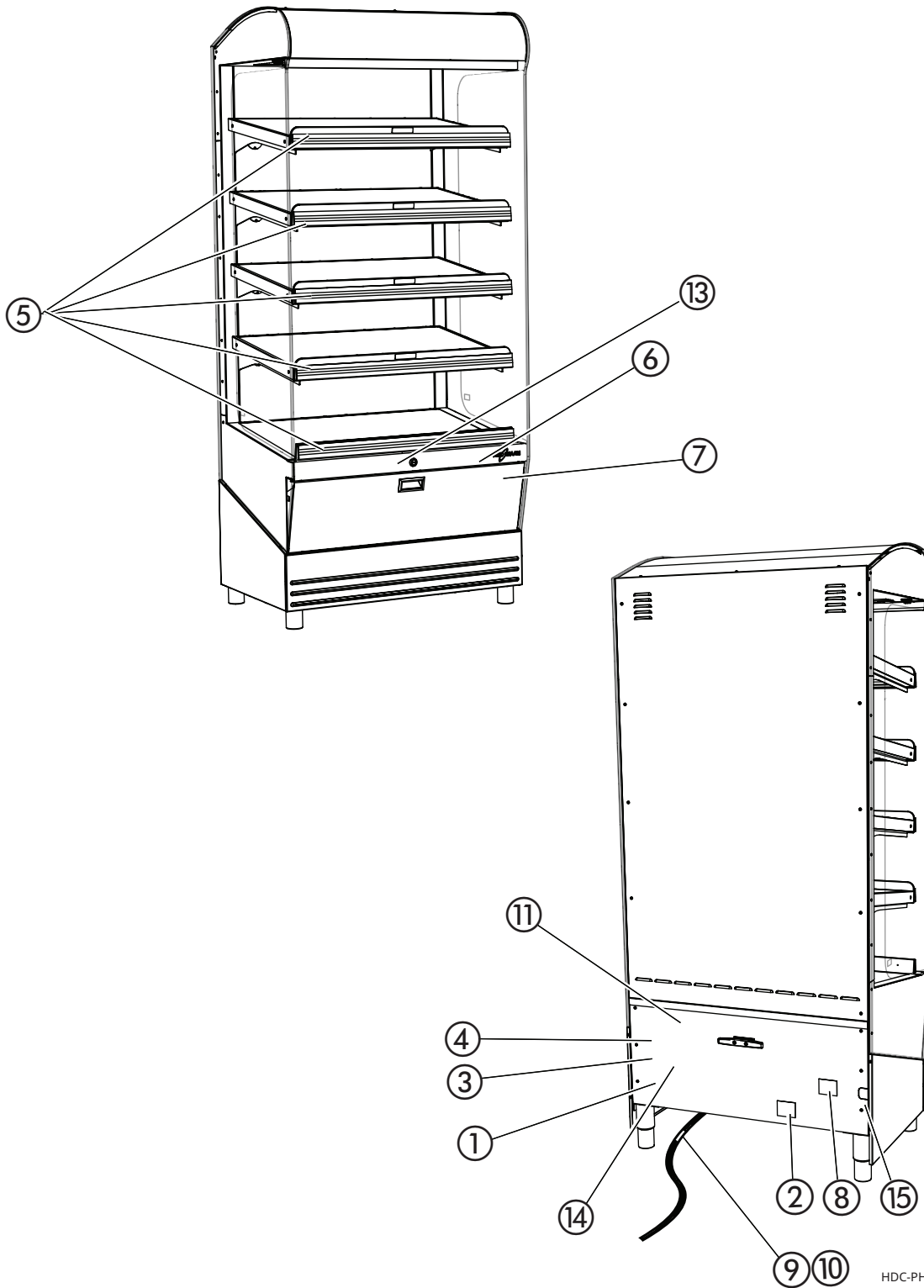

This page is intentionally left blank.







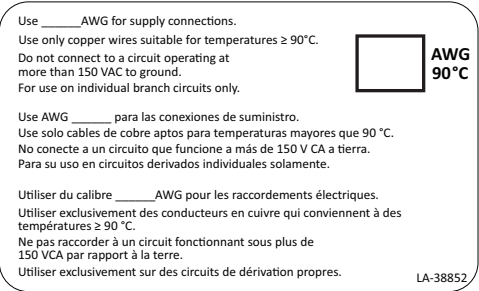
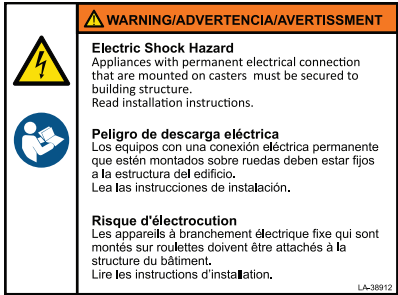
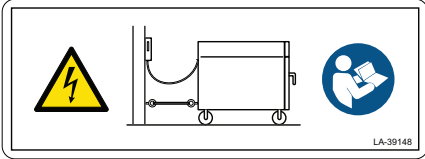

# Label Locations



HDC-PHD-015312

LABELS

<p>1</p>	 	<p>WARNING</p> <p>Electric shock hazard</p> <p>To reduce the risk of electric shock, do not remove or open the cover. No user-serviceable parts inside. Refer servicing to qualified personnel. Qualified personnel: Disconnect power before servicing.</p>
<p>2</p>		<p><b>Note:</b> This label is only used on UL-certified appliances that have 150V to ground wiring.</p> <p>Use _____ AWG for supply connections.</p> <p>Use only copper wires suitable for temperature less than or equal to 90°C.</p> <p>Do not connect to a circuit operating at more than 150 VAC to ground.</p> <p>For use on individual branch circuits only.</p>
<p>3</p>	 	<p>WARNING</p> <p>Electric shock hazard</p> <p>Appliances with permanent electrical connection that are mounted on casters must be secured to building structure. Read installation instructions.</p>
<p>4</p>		<p>Every Alto-Shaam product is precision calibrated prior to release from the factory to ensure accurate temperature control.</p>

5		<p>WARNING Hot surface</p>				
6		<p>Made in U.S.A.</p>				
7		<p>Security seal</p>				
8	<p>For use on individual branch circuit only.</p> <p>Utiliser exclusivement sur un propre circuit de dérivation séparé.</p> <p>Nur zum Anschluss an einen Einzelstromkreis geeignet.</p> <p>Para su uso en circuitos derivados individuales solamente.</p> <p>禁止和其他任何电器设备共用供电回路。必须独立分配一路给该设备</p> <p>LA-3088</p>	<p>For use on individual branch circuit only.</p>				
9	<table border="1" data-bbox="261 1066 837 1203"> <tr> <td data-bbox="261 1066 315 1203">  </td> <td data-bbox="315 1066 521 1203"> <p><b>WARNING</b></p> <p><b>Fire Hazard</b> Use a UL Listed grounding type plug rated 120 Volts, 30 Amperes, 1 Phase, 3 wire for single phase units. Plug to be selected and installed only by qualified service personnel.</p> </td> <td data-bbox="521 1066 574 1203"> <p>120V, 30A</p> </td> <td data-bbox="574 1066 837 1203"> <p><b>ADVERTENCIA/AVERTISSEMENT</b></p> <p><b>Peligro de incendio</b> Utilice un enchufe con toma de tierra de los que se incluyen en las listas de la UL de 120 voltios, 30 amperios, monofásico de 3 hilos para unidades monofásicas. La elección e instalación del enchufe la realizará exclusivamente personal cualificado del servicio.</p> <p><b>Risque d'incendie</b> Utilisez une prise homologuée UL conforme pour 120 Volts, 30 Amperes, monophasé, 3 fils pour les appareils monophasés. Les prises ne doivent être sélectionnées et installées que par du personnel de service qualifié. لا يجوز</p> </td> </tr> </table>		<p><b>WARNING</b></p> <p><b>Fire Hazard</b> Use a UL Listed grounding type plug rated 120 Volts, 30 Amperes, 1 Phase, 3 wire for single phase units. Plug to be selected and installed only by qualified service personnel.</p>	<p>120V, 30A</p>	<p><b>ADVERTENCIA/AVERTISSEMENT</b></p> <p><b>Peligro de incendio</b> Utilice un enchufe con toma de tierra de los que se incluyen en las listas de la UL de 120 voltios, 30 amperios, monofásico de 3 hilos para unidades monofásicas. La elección e instalación del enchufe la realizará exclusivamente personal cualificado del servicio.</p> <p><b>Risque d'incendie</b> Utilisez une prise homologuée UL conforme pour 120 Volts, 30 Amperes, monophasé, 3 fils pour les appareils monophasés. Les prises ne doivent être sélectionnées et installées que par du personnel de service qualifié. لا يجوز</p>	<p>WARNING Fire hazard</p> <p>Use a UL Listed grounding type plug rated 120 Volts, 30 Amperes, 1 Phase, 3 wire for single phase units. Plug to be selected and installed only by qualified service personnel.</p> <p>*For use on units with cords, no plugs.</p>
	<p><b>WARNING</b></p> <p><b>Fire Hazard</b> Use a UL Listed grounding type plug rated 120 Volts, 30 Amperes, 1 Phase, 3 wire for single phase units. Plug to be selected and installed only by qualified service personnel.</p>	<p>120V, 30A</p>	<p><b>ADVERTENCIA/AVERTISSEMENT</b></p> <p><b>Peligro de incendio</b> Utilice un enchufe con toma de tierra de los que se incluyen en las listas de la UL de 120 voltios, 30 amperios, monofásico de 3 hilos para unidades monofásicas. La elección e instalación del enchufe la realizará exclusivamente personal cualificado del servicio.</p> <p><b>Risque d'incendie</b> Utilisez une prise homologuée UL conforme pour 120 Volts, 30 Amperes, monophasé, 3 fils pour les appareils monophasés. Les prises ne doivent être sélectionnées et installées que par du personnel de service qualifié. لا يجوز</p>			
10	<table border="1" data-bbox="261 1350 837 1486"> <tr> <td data-bbox="261 1350 315 1486">  </td> <td data-bbox="315 1350 521 1486"> <p><b>WARNING</b></p> <p><b>Fire Hazard</b> Use a UL Listed grounding type plug rated 240 Volts, 20 Amperes, 1 Phase, 3 wire for single phase units. Plug to be selected and installed only by qualified service personnel.</p> </td> <td data-bbox="521 1350 574 1486"> <p>240V, 20A</p> </td> <td data-bbox="574 1350 837 1486"> <p><b>ADVERTENCIA/AVERTISSEMENT</b></p> <p><b>Peligro de incendio</b> Utilice un enchufe con toma de tierra de los que se incluyen en las listas de la UL de 240 voltios, 20 amperios, monofásico de 3 hilos para unidades monofásicas. La elección e instalación del enchufe la realizará exclusivamente personal cualificado del servicio.</p> <p><b>Risque d'incendie</b> Utilisez une prise homologuée UL conforme pour 240 Volts, 20 Amperes, monophasé, 3 fils pour les appareils monophasés. Les prises ne doivent être sélectionnées et installées que par du personnel de service qualifié. لا يجوز</p> </td> </tr> </table>		<p><b>WARNING</b></p> <p><b>Fire Hazard</b> Use a UL Listed grounding type plug rated 240 Volts, 20 Amperes, 1 Phase, 3 wire for single phase units. Plug to be selected and installed only by qualified service personnel.</p>	<p>240V, 20A</p>	<p><b>ADVERTENCIA/AVERTISSEMENT</b></p> <p><b>Peligro de incendio</b> Utilice un enchufe con toma de tierra de los que se incluyen en las listas de la UL de 240 voltios, 20 amperios, monofásico de 3 hilos para unidades monofásicas. La elección e instalación del enchufe la realizará exclusivamente personal cualificado del servicio.</p> <p><b>Risque d'incendie</b> Utilisez une prise homologuée UL conforme pour 240 Volts, 20 Amperes, monophasé, 3 fils pour les appareils monophasés. Les prises ne doivent être sélectionnées et installées que par du personnel de service qualifié. لا يجوز</p>	<p>WARNING Fire hazard</p> <p>Use a UL Listed grounding type plug rated 240 Volts, 20 Amperes, 1 Phase, 3 wire for single phase units. Plug to be selected and installed only by qualified service personnel.</p> <p>*For use on units with cords, no plugs.</p>
	<p><b>WARNING</b></p> <p><b>Fire Hazard</b> Use a UL Listed grounding type plug rated 240 Volts, 20 Amperes, 1 Phase, 3 wire for single phase units. Plug to be selected and installed only by qualified service personnel.</p>	<p>240V, 20A</p>	<p><b>ADVERTENCIA/AVERTISSEMENT</b></p> <p><b>Peligro de incendio</b> Utilice un enchufe con toma de tierra de los que se incluyen en las listas de la UL de 240 voltios, 20 amperios, monofásico de 3 hilos para unidades monofásicas. La elección e instalación del enchufe la realizará exclusivamente personal cualificado del servicio.</p> <p><b>Risque d'incendie</b> Utilisez une prise homologuée UL conforme pour 240 Volts, 20 Amperes, monophasé, 3 fils pour les appareils monophasés. Les prises ne doivent être sélectionnées et installées que par du personnel de service qualifié. لا يجوز</p>			

11



WARNING

Fire hazard

This appliance is only for use with factor-supplied legs, casters, or base.

12



Consult instructions for operation and use.

13

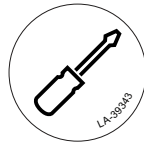

Use a flat-head screwdriver or coin to unlock.

14

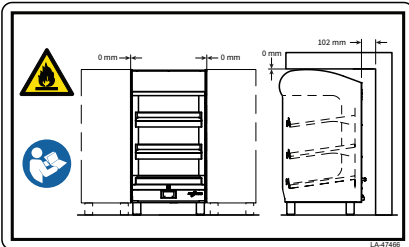
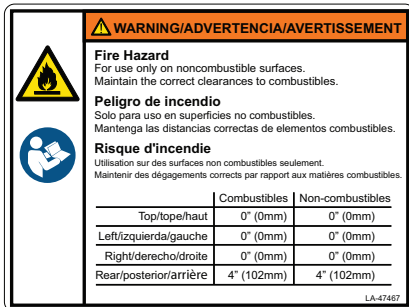

WARNING

Fire hazard

For use only on noncombustible surfaces.

Maintain the correct clearances to combustibles.

15



Equipotential terminal



# Dimension Drawings

## HSM-24/3S/T

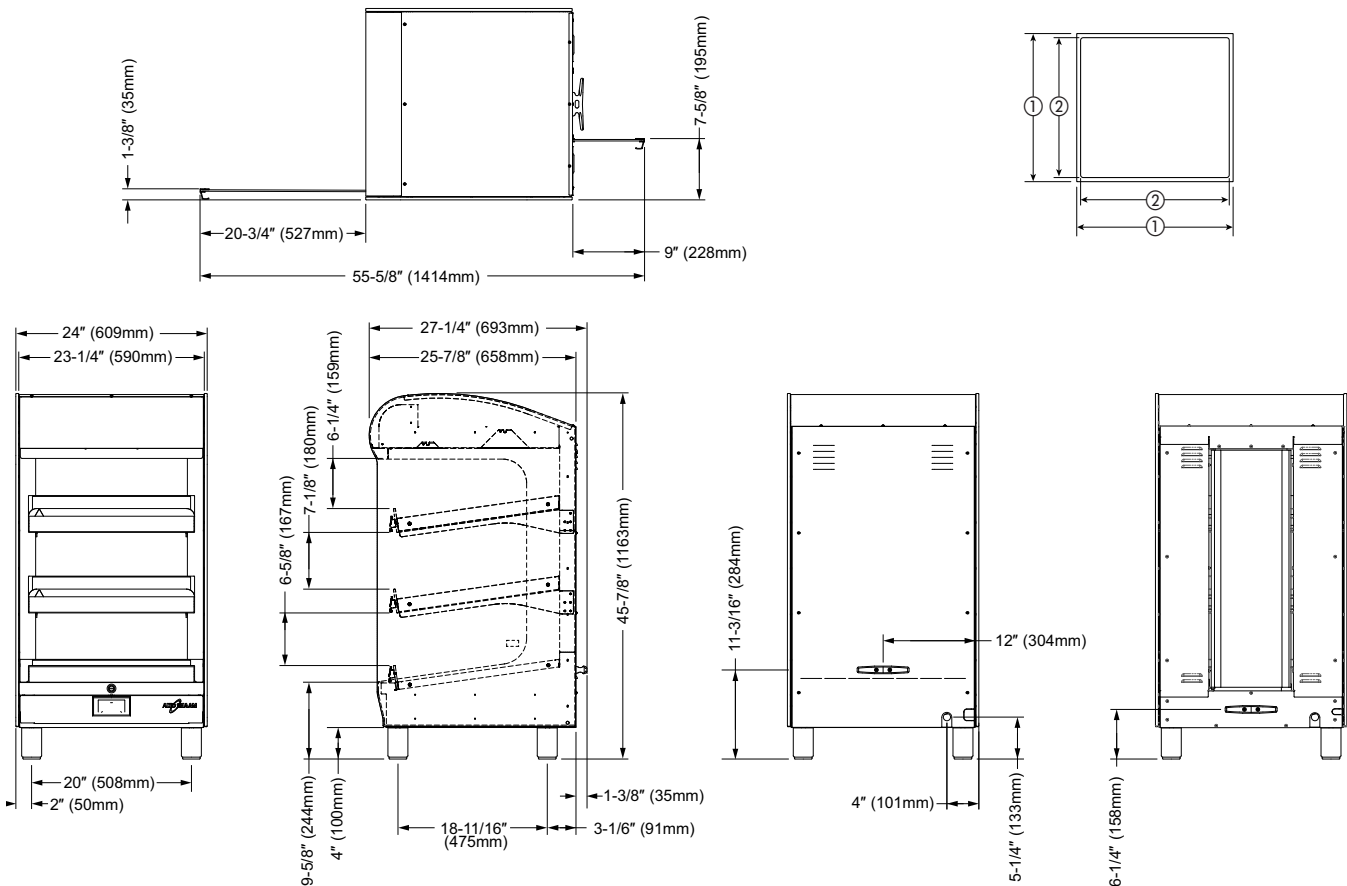

INSTALLATION

# HSM-24/5S/T

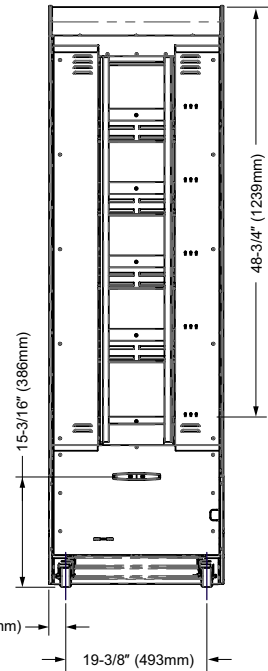
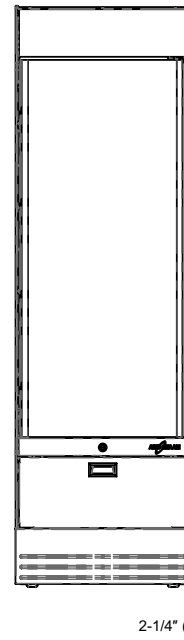
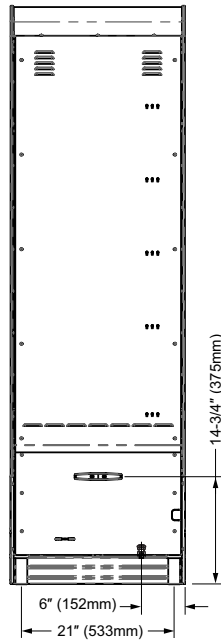
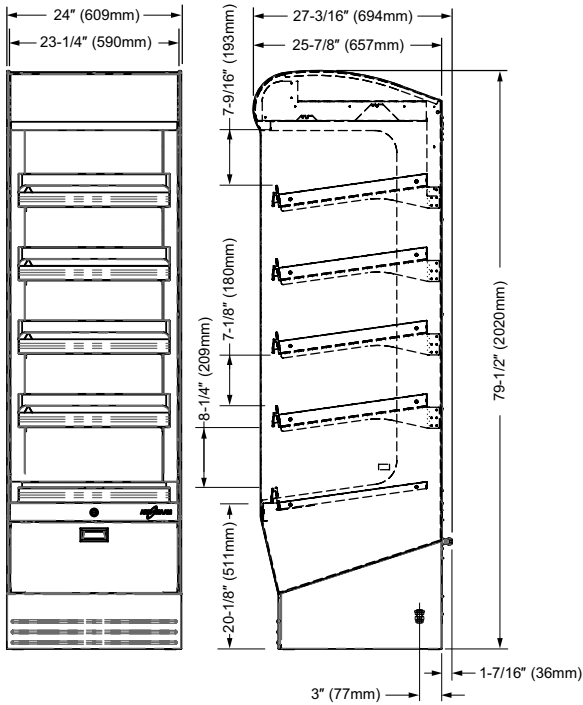
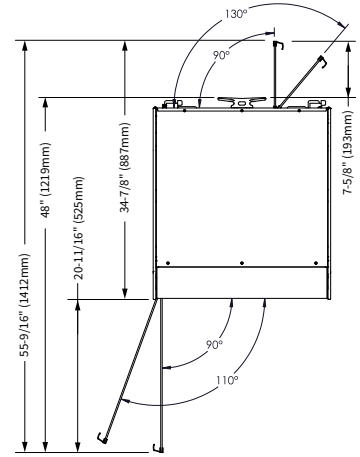
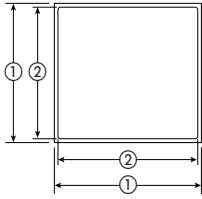

# HSM-36/2S/T

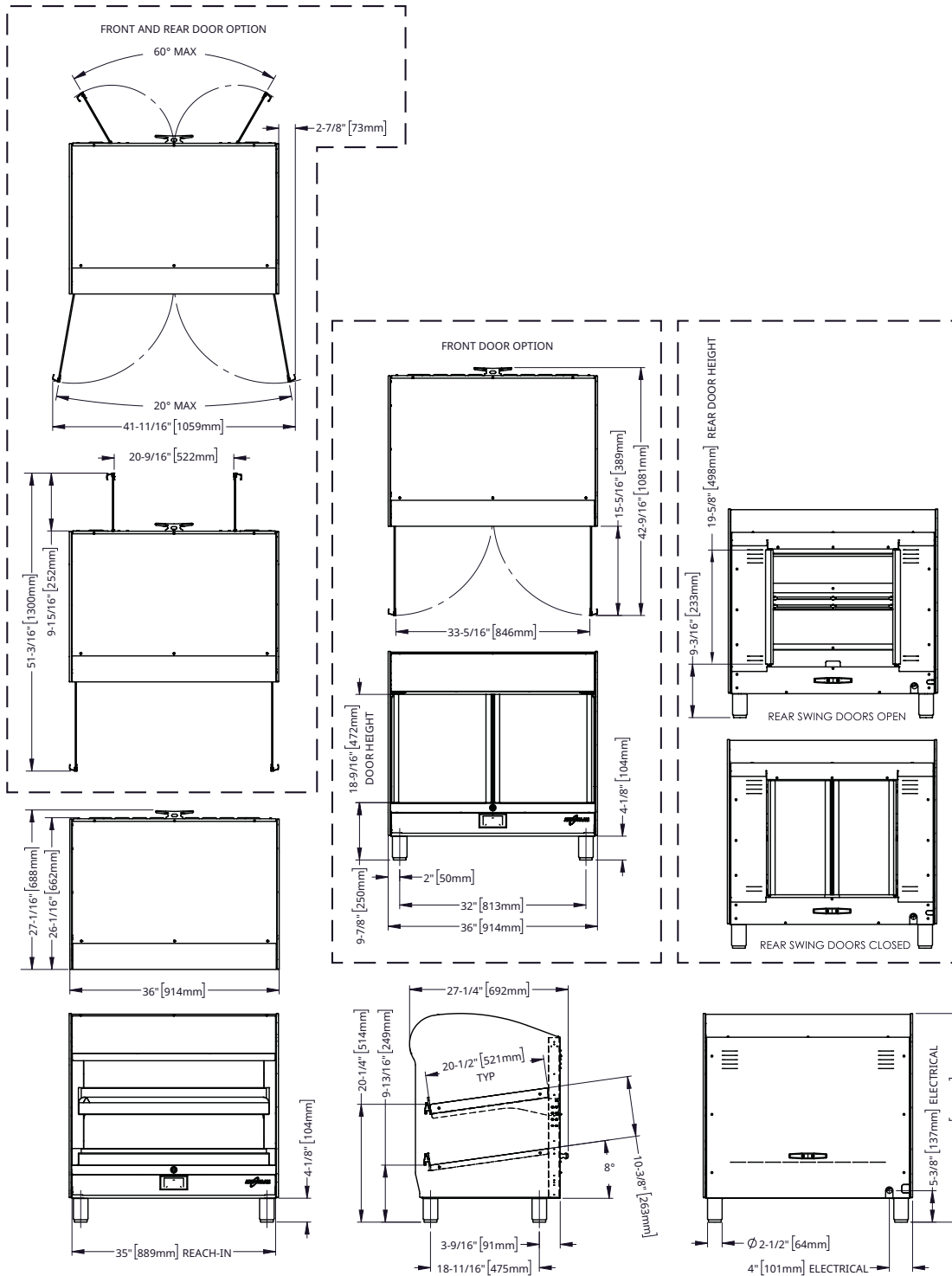

# HSM-36/3S/T

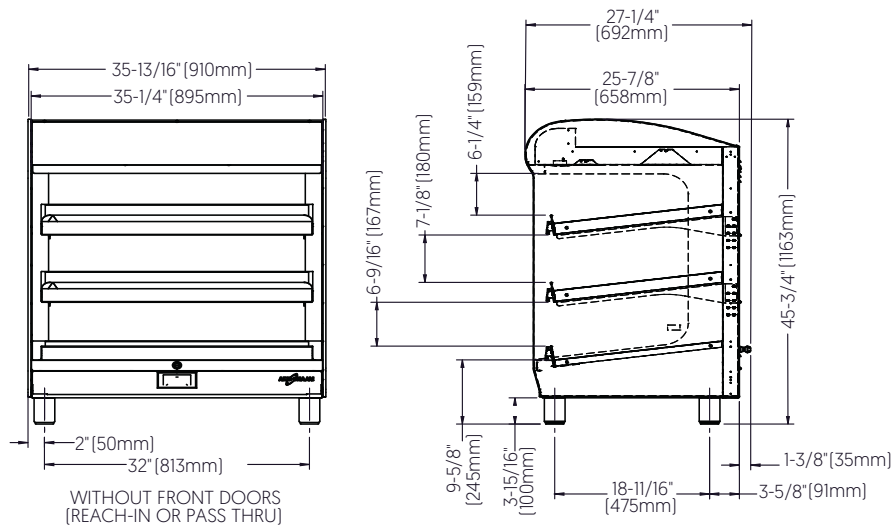
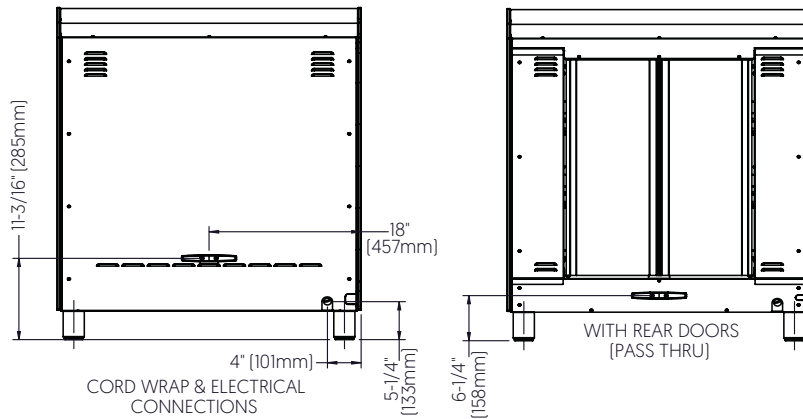
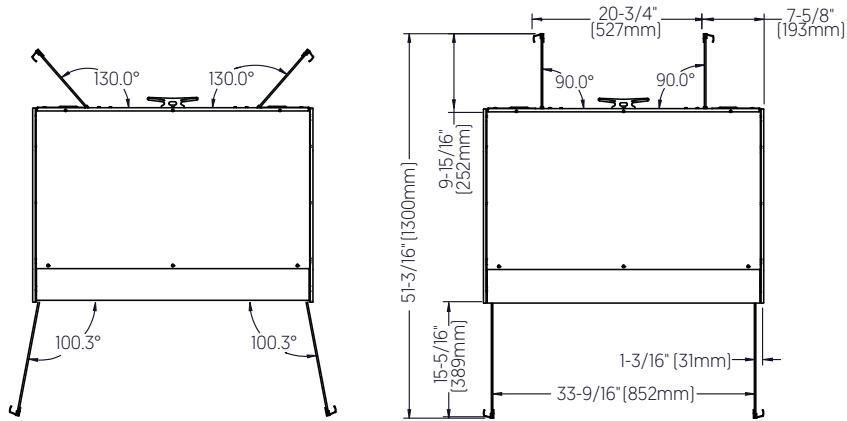

# HSM-36/5S/T

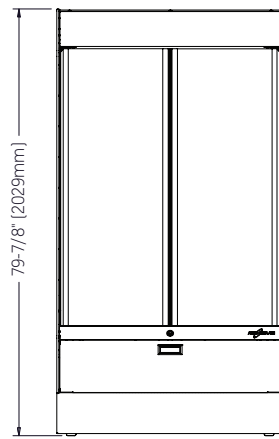
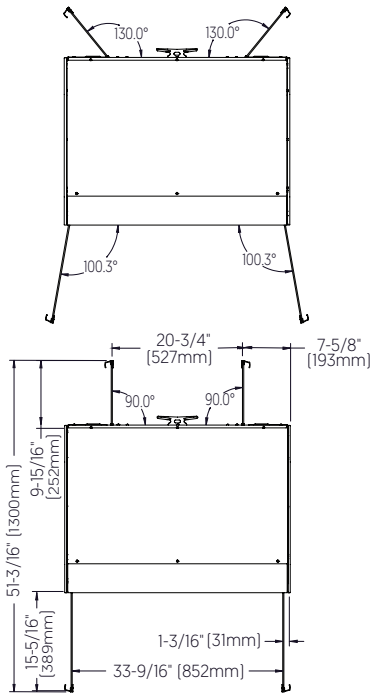

FRONT WITH DOORS & CASTERS

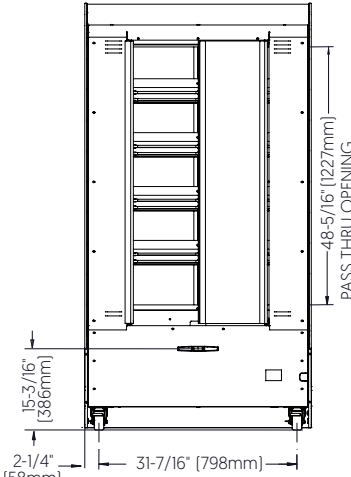

BACK VIEW WITH SWING DOOR

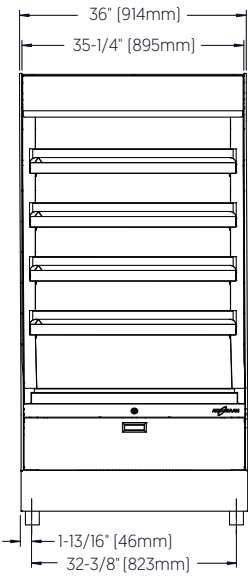

FRONT WITH FEET

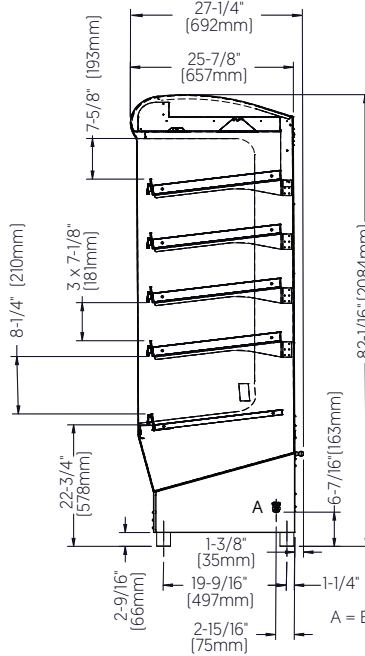

A = ELECTRIC CONNECTION

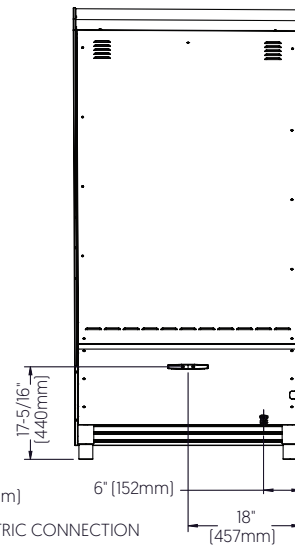

# HSM-48/5S/T

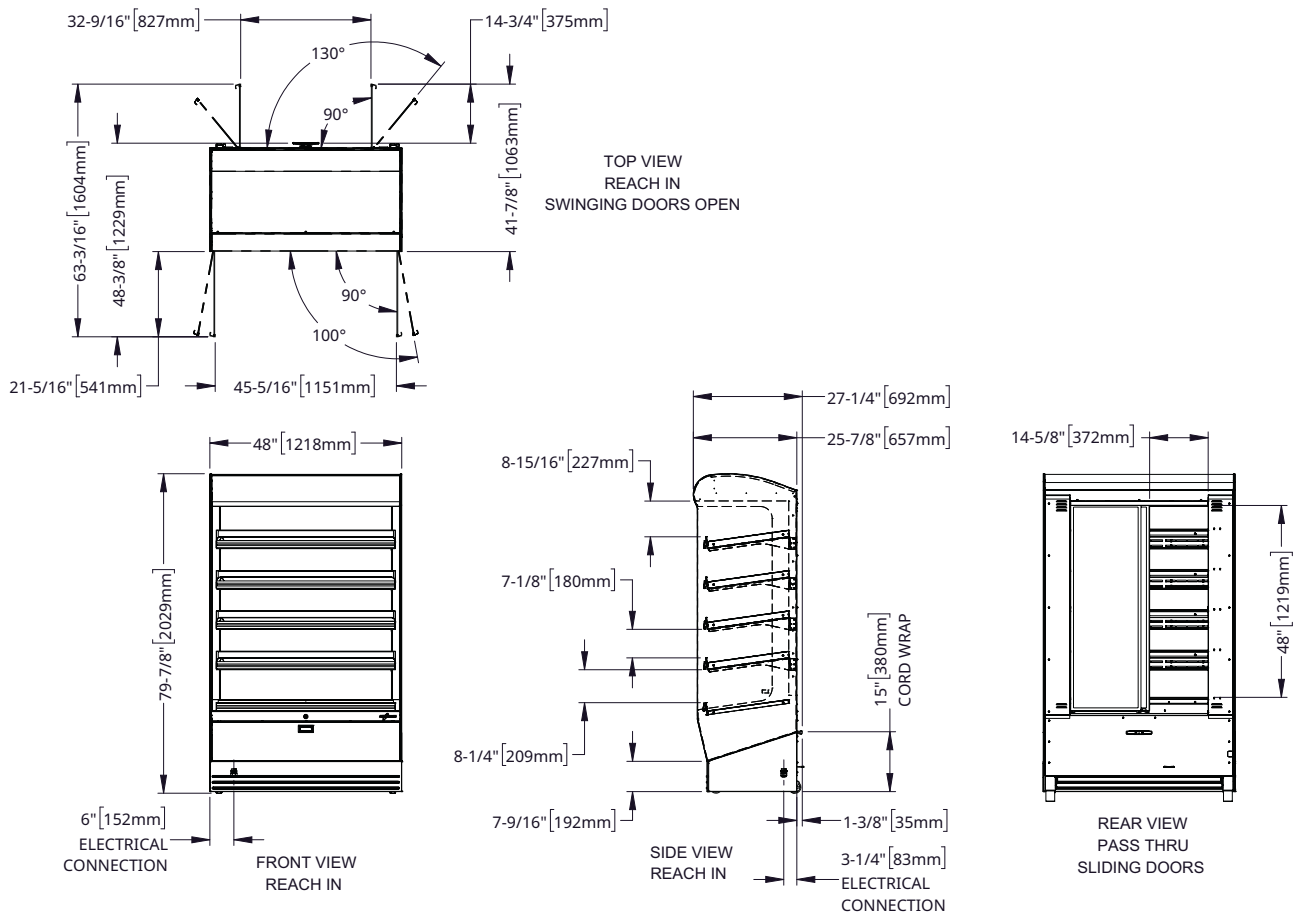

# How to Receive the Appliance

## Responsible parties

When an Alto-Shaam® preferred carrier is used, shipping damage is a matter between Alto-Shaam and the carrier. In such cases, contact Alto-Shaam customer service.

When an Alto-Shaam non-preferred carrier is used, shipping damage is a matter between the carrier and the consignee. In such cases, the carrier is assumed to be responsible for the safe delivery of the merchandise, unless negligence can be established on part of the shipper.

## Receive the appliance

When receiving the appliance, do the following.

Step	Action
1.	<b>Inspect</b> the equipment while it is still in the truck or immediately after it is moved to the receiving area. Do not wait until after the equipment is moved to a storage area.
2.	<b>Inspect and count</b> all merchandise received. Do not sign a delivery receipt or a freight bill until you have done so.
3.	<b>Note</b> all damage to packaging and to the equipment on the carrier's receipt.
4.	<b>Request</b> the driver sign the delivery receipt. If the driver refuses to sign, make a note of this refusal on the delivery receipt.
5.	<b>Write</b> the following on the delivery receipt if the driver refuses to allow an inspection: Driver refuses to allow inspection of containers for visible damage.
6.	<b>Contact</b> the carrier immediately upon finding damage, and request an inspection. <b>Follow</b> the carrier's policies and procedures.

## Alto-Shaam policy

It is the policy of Alto-Shaam to assist customers in collecting claims that have been properly filed and actively pursued. Alto-Shaam cannot, however, file damage claims, assume the responsibilities for damage claims, or accept deductions in payment for damage claims.

# How to Unpack the Merchandiser

## Before you begin

### Make sure you have:

- An appropriate lifting device and enough personnel to safely move and position the weight of the merchandiser.

Model	Weight	Model	Weight
HSM-24/3S/T	250 lb (113 kg)	HSM-36/3S/T	311 lb (141 kg)
HSM-24/5S/T	406 lb (184 kg)	HSM-36/5S/T	496 lb (225 kg)
HSM-36/2S/T	224 lb (102 kg)	HSM-48/5S/T	563 lb (255 kg)

- Cutting tools to remove the packaging and hand tools to remove the bolts.

## Unpacking

To unpack the merchandiser, do the following.

Step	Action
------	--------

- |    |  |
|----|--|
| 1. | <b>Remove</b> the box by cutting the top off. Then, remove the staples holding the box to the pallet, cut the sides into manageable pieces and remove the pieces. <b>Save</b> all packing materials for inspection by the carrier. |
|----|--|



**NOTE:** Examine the appliance for damage. If the appliance has been damaged, do not use the appliance until it has been inspected by an authorized service provider. Contact your carrier or Alto-Shaam® customer service.

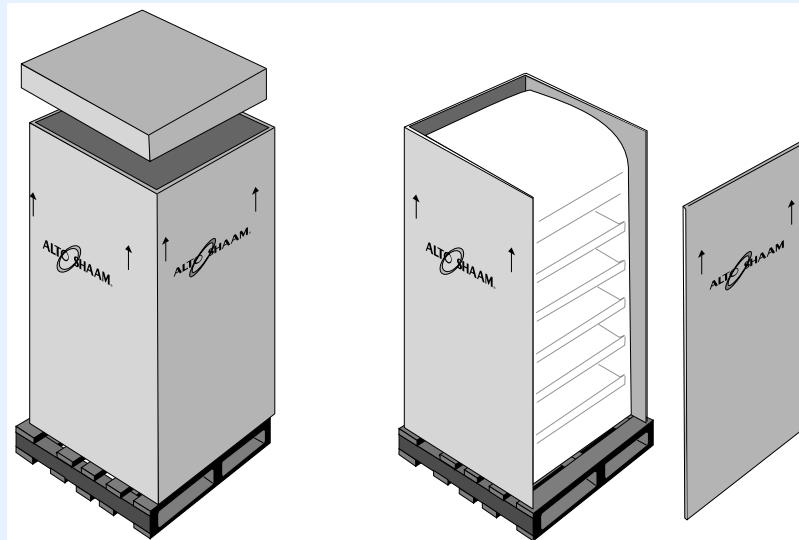

HDC-TS-015318

*Continued on next page*



Continued from previous page

2. **Position** the lifting device under the merchandiser from the front. Position the forks of the lifting device near the legs/casters. The pallet may be oversized, in such cases, raise the pallet and block it just enough so that the lifting device can fit underneath the pallet.

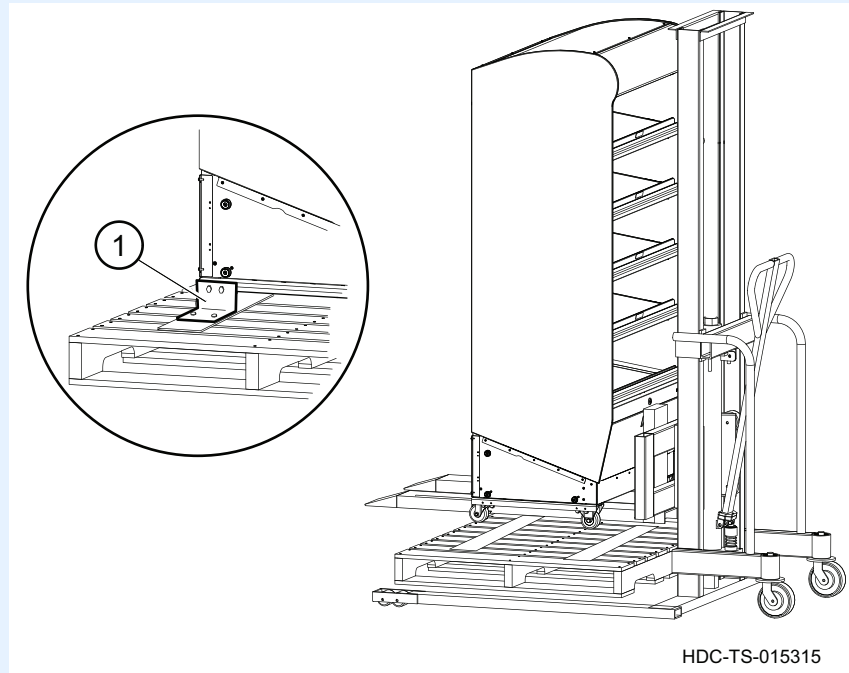

HDC-TS-015315

3. **Remove** the brackets ① holding the merchandiser to the pallet. **Discard** brackets.
4. **Lift** the merchandiser from the pallet. **Move** it away from the pallet and set it on the floor. **Remove** the lifting device from the merchandiser.
5. **Remove** the skirting from the shrink wrap if applicable. **Remove** the shrink wrap and the shelf support framework from the merchandiser.
6. **Retrieve** the manual from the interior of the merchandiser. **Refer** to it for installation and operation information.

## Result

The merchandiser is now unpacked.

# How to Install the Merchandiser

## Before you begin

Make sure you have:

- An appropriate lifting device, and enough personnel, to safely move and position the weight of the merchandiser
- Basic Hand Tools

## Requirements

- The merchandiser must be installed on a level surface.
- Do not install the merchandiser near a cold air source such as, a freezer, air conditioner, or an area where outside air can affect its performance.
- The merchandiser must not be installed in any area where it may be affected by steam, grease, dripping water, high temperature, or any other severely adverse conditions.

## Voltages

	Ph	Hz	AWG	IEC	A	Breaker	kW	Plug Options
<b>HSM-24/3S/T</b> 120V	1	50/60	12	---	7.1	15	1.7	NEMA5-20P
208-240V	1	50/60	12	---	6.23-7.15	15	1.3-1.72	NEMA5-15P NEMA6-20P Cord, no plug
230V	1	50/60	---	4	6.58	16	1.58	CEE 7/7, BS1363, CH-2-16
<b>HSM-24/5S/T</b> 208-240V	1	50/60	10	---	10.39-11.92	15	2.16-2.86	NEMA6-15P NEMA6-20P Cord, no plug
230V	1	50/60	---	6	10.97	16	2.63	CEE 7/7, BS1363, CH-2-16
<b>HSM-36/2S/T</b> 120V	1	50/60	12	---	13.21	15	1.59	NEMA5-15P NEMA5-20P Cord, no plug
208-240V	1	50/60	12	---	5.8-6.7	15	1.21-1.61	NEMA6-15P NEMA6-20P Cord, no plug
230V	1	50/60	---	4	7.12	15	1.55	CEE 7/7, BS1363, CH-2-16
<b>HSM-36/3S/T</b> 208-240V	1	50/60	10	---	8.75-10.04	15	1.82-2.41	NEMA6-15P NEMA6-20P Cord, no plug
230V	1	50/60	---	6	9	15	2.0	CEE 7/7, BS1363, CH-2-16

Electrical connections must meet all applicable federal, state, and local codes. Dedicated circuit required.

*Continued on next page*

Continued from previous page

<b>HSM-36/5S/T</b> 208-240V	1	50/60	10	---	14.58- 16.73	25	3.03- 4.02	NEMA6-15P NEMA6-20P Cord, no plug
230V	1	50/60	---	6	15	20	3.45	CEE 7/7, BS1363, CH-2-16
<b>HSM-48/5S/T</b> 208-240V	1	50/60	8		20.1- 22.3	30	4.19- 5.35	NEMA6-15P NEMA6-20P Cord, no plug
230V	1	50/60	---	10	20.37	30	4.89	CEE 7/7, BS1363, CH-2-16

Electrical connections must meet all applicable federal, state, and local codes.  
Dedicated circuit required.

## Electrical connection



**WARNING:** Appliances without a cord provided by the factory must be equipped with a cord of sufficient length to permit the appliance to be moved for cleaning.

Always use the correct AWG wire size based on the electrical requirements for the appliance.



**WARNING:** To prevent serious injury, death, or property damage:

All electrical connections must be made by a qualified and trained service technician in accordance with applicable electrical codes.

This appliance must be adequately grounded in accordance with local electrical codes or, in the absence of local codes, with the current edition of the National Electrical Code ANSI/NFPA No 70. In Canada, all electrical connections are to be made in accordance with CSA C22 1, Canadian Electrical Code Part 1 or local codes.

CE-approved appliances include an equipotential-bonding terminal marked with the equipotential symbol. Provisions for earthing are to be made in accordance with IEC:2010 60335-1 section 27 or local codes.



**WARNING:** Electric shock hazard.

Power source must match voltage identified on appliance rating tag. The rating tag provides essential technical information required for any appliance installation, maintenance or repairs. Do not remove, damage or modify the rating tag.

Continued on next page

*Continued from previous page*

## Regarding international standard merchandisers:

If the unit is not equipped with flexible cord and plug, an all-pole country approved disconnection device which has a contact separation of at least 3mm in all poles must be incorporated in the fixed wiring for disconnection. When using a cord without a plug, the green/yellow conductor shall be connected to the terminal which is marked with the ground symbol. If a plug is used, the socket outlet must be easily accessible. If the power cord needs replacement, use a similar one obtained from the distributor.

## Hard-wired models:

Hard-wired models must be equipped with a country-certified, external, all-pole disconnection switch with sufficient contact separation. Hard-wired models that are mounted on casters must have a strain relief device (tether) to prevent strain on the power supply cord. If a power cord is used for the connection of the product, an oil resistant cord like H05RN or H07RN or equivalent must be used.

### NOTICE

Where local codes and CE regulatory requirements apply, appliances must be connected to an electrical circuit that is protected by an external GFCI outlet.

## Restraint Requirements



### WARNING: Electric shock hazard

Appliance must be secured to building structure. Failure to observe this precaution may result in severe personal injury and damage to the equipment.

Requirements for restraint:

- Maximum height of casters is 6" (152mm).
- Two of the casters must be of the locking type.
- Strain relief devices (tethers) must be secured to the building structure.

A mounting connector for a restraining device (tether) is located on the back of the appliance. The restraining device (tether) is not supplied by nor is it available from the factory.

*Continued on next page*

Continued from previous page

**Position the merchandiser**

To position the merchandiser, do the following.

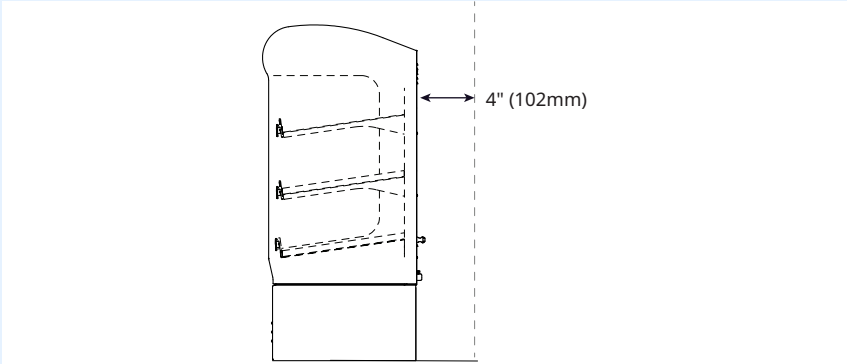
Step	Action
1.	<p><b>Make sure</b> that:</p> <ul style="list-style-type: none"> <li>■ The location where the merchandiser is being installed is rated to support the weight of the merchandiser;</li> <li>■ The merchandiser is within five feet (1.5 m) of the appropriate electrical outlet;</li> <li>■ You follow the merchandiser clearance guidelines.</li> </ul> 
2.	<p><b>Move</b> the merchandiser to the installation location and onto the final resting surface.  <b>Apply</b> the brakes of the front casters (if applicable).</p>
3.	<p><b>See topic</b> <i>How to Clean the Merchandiser</i>, and thoroughly clean the merchandiser before continuing.</p>
4.	<p>For merchandisers without plugs, do the following.  <b>See topic</b> <i>How to Install the Merchandiser (Without Cord or Plug)</i>.</p> <p>For merchandisers with plugs and cords, do the following.  <b>Plug</b> the merchandiser into a properly grounded receptacle.</p>

**Connecting power**

Continued on next page

Continued from previous page

## Install the tether (if required)

5. **Install** a restraining device (tether) between the merchandiser and the building's structure so no stress is transmitted to the electrical connections when the oven moves.

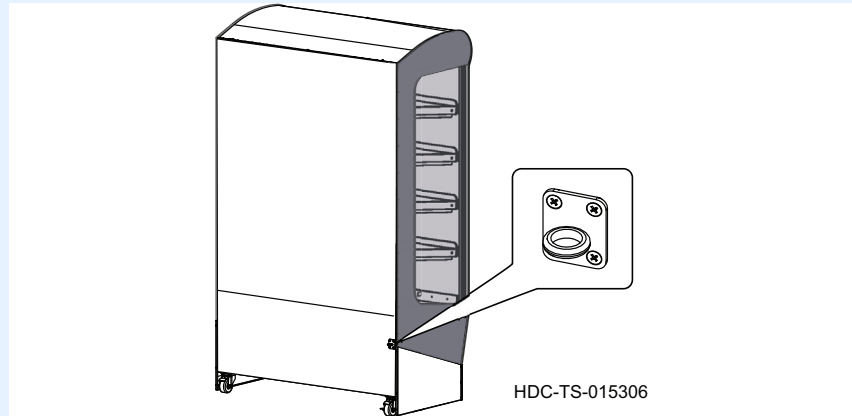

## Bonding terminal (if required)

6. Connect the merchandiser at the equipotential-bonding terminal if required.



**NOTE:** The equipotential-bonding terminal is located at the bottom rear of the oven

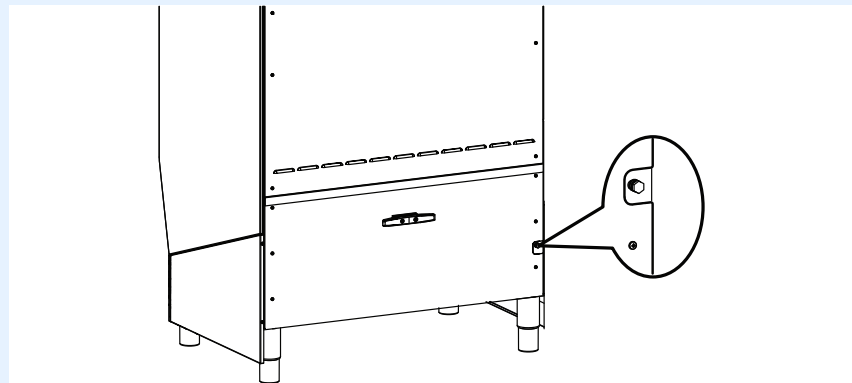

## Result

The merchandiser is now installed.

# How to Install the Merchandiser (Without Cord or Plug)

## Before you begin

Make sure you have:

- An appropriate lifting device, and enough personnel, to safely move and position the weight of the merchandiser
- Appropriate cord and plug, minimum oil resistant HO7RN-F. See local codes and regulations
- Screwdriver (Phillips #2)
- Nut driver (1/4-inch)

## Requirements

- The merchandiser must be installed on a level surface.
- The merchandiser must not be installed in any area where it may be affected by steam, grease, dripping water, high temperature, or any other severely adverse conditions.

## Voltages

For the list of voltages, **See Topic** *How to Install a Merchandiser*.

## Electrical connection



**WARNING:** Appliances without a cord provided by the factory must be equipped with a cord of sufficient length to permit the appliance to be moved for cleaning.

Always use the correct AWG wire size based on the electrical requirements for the appliance.



**WARNING:** To prevent serious injury, death, or property damage:

All electrical connections must be made by a qualified and trained service technician in accordance with applicable electrical codes.

This appliance must be adequately grounded in accordance with local electrical codes or, in the absence of local codes, with the current edition of the National Electrical Code ANSI/NFPA No 70. In Canada, all electrical connections are to be made in accordance with CSA C22 1, Canadian Electrical Code Part 1 or local codes.

CE-approved appliances include an equipotential-bonding terminal marked with the equipotential symbol. Provisions for earthing are to be made in accordance with IEC:2010 60335-1 section 27 or local codes.



**CAUTION:** Electric shock hazard.

Power source must match voltage identified on appliance rating tag. The rating tag provides essential technical information required for any appliance installation, maintenance or repairs. Do not remove, damage or modify the rating tag.

**Regarding international standard merchandisers:**

If the unit is not equipped with flexible cord and plug, an all-pole country approved disconnection device which has a contact separation of at least 3mm in all poles must be incorporated in the fixed wiring for disconnection. When using a cord without a plug, the green/yellow conductor shall be connected to the terminal which is marked with the ground symbol. If a plug is used, the socket outlet must be easily accessible. If the power cord needs replacement, use a similar one obtained from the distributor.

**Hard-wired models:**

Hard-wired models must be equipped with a country-certified, external, all-pole disconnection switch with sufficient contact separation. Hard-wired models that are mounted on casters must have a strain relief device (tether) to prevent strain on the power supply cord. If a power cord is used for the connection of the product, an oil resistant cord like H05RN or H07RN or equivalent must be used.

**NOTICE**

Where local codes and CE regulatory requirements apply, appliances must be connected to an electrical circuit that is protected by an external GFCI outlet.

**Restraint Requirements**



**WARNING:** Electric shock hazard

Appliance must be secured to building structure. Failure to observe this precaution may result in severe personal injury and damage to the equipment.

Requirements for restraint:

- Maximum height of casters is 6" (152mm).
- Two of the casters must be of the locking type.
- Strain relief devices (tethers) must be secured to the building structure.

A mounting connector for a restraining device (tether) is located on the back of the appliance. The restraining device (tether) is not supplied by nor is it available from the factory.

*Continued on next page*



Continued from previous page

## Wire Sizes

60335-1 IEC:2010

Rated current of appliance A	Nominal cross-sectional area mm <sup>2</sup>
>0.2 - ≤ 3	0.5
>3 - ≤ 0	0.75
>6 - ≤ 10	1.0
>10 - ≤ 16	1.5
>16 - ≤ 25	2.5
>25 - ≤ 32	4
>32 - ≤ 40	6
>40 - ≤ 63	10

## Level the merchandiser

To level the merchandiser, do the following.

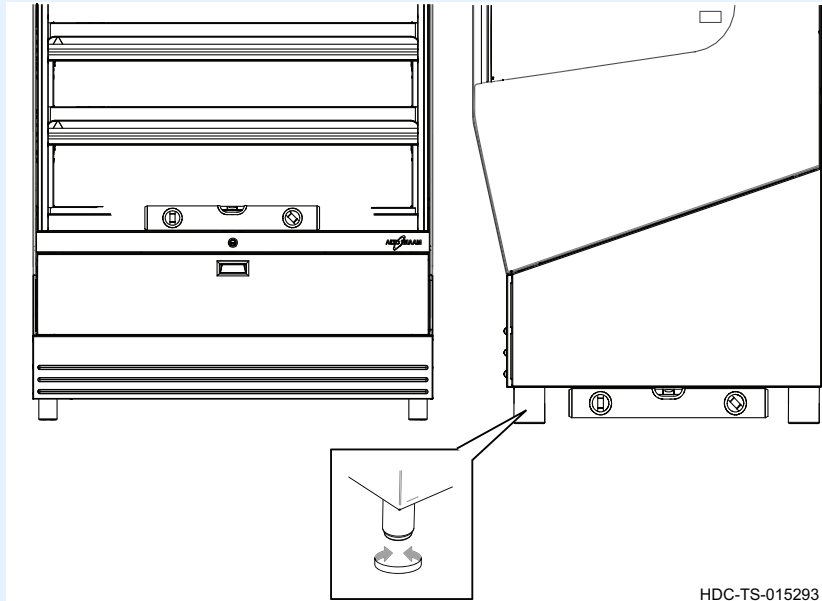
Step	Action
1.	<p><b>Check</b> the level of the merchandiser using a spirit (bubble) level. Check front to back and side to side.</p>  <p><b>Adjust</b> the legs, if necessary, to achieve levelness.</p> <p style="text-align: right;">HDC-TS-015293</p>

The merchandiser is now level.

Continued on next page

Continued from previous page

## Connect the wiring

To connect the wiring, do the following.

2. **Remove** the top cover.



**WARNING:** Electric shock hazard.

Make sure the supply cord is not connected to a power supply.

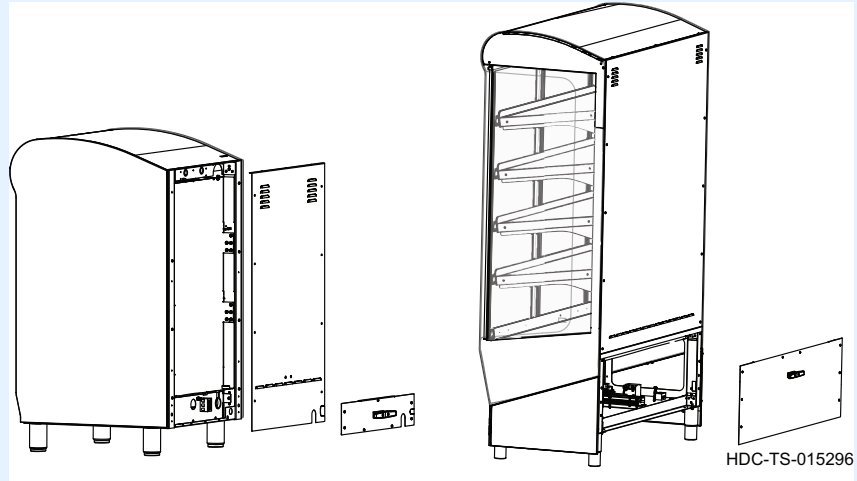

The countertop merchandiser may have a full-size back panel or a small back panel. The panel type will depend on the specific model.

3. **Install** the cord through the cord grip.  
**Install** the cord and cord grip into the merchandiser.  
**Install** the lock nut onto the cord grip.
4. **Connect** the supply cord to the appropriate terminals (L1, L2, etc.) in accordance with local codes and regulations.

Continued on next page

Continued from previous page

5. **Install** the ground wire.

**Leave** an extra loop so that current-carrying conductors become taut before the ground wire if the cord is accidentally pulled. Follow applicable regulations.

**Tighten** the cord grip sealing nut onto the supply cord.

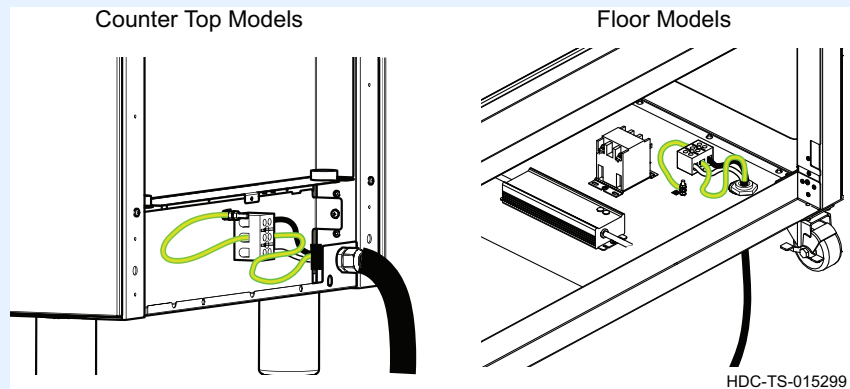

Continued on next page

Continued from previous page

## Install the tether (if required)

6. **Install** a restraining device (tether) between the merchandiser and the building's structure so no stress is transmitted to the electrical connections when the oven moves.

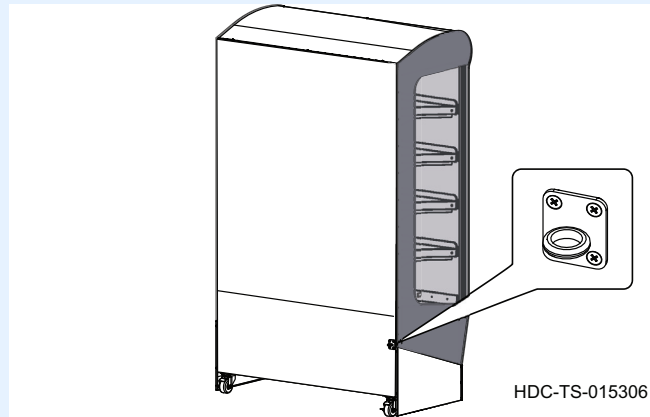

## Bonding terminal (if required)

7. **Connect** the merchandiser at the equipotential-bonding terminal if required.



**NOTE:** The equipotential-bonding terminal is located at the bottom rear of the oven

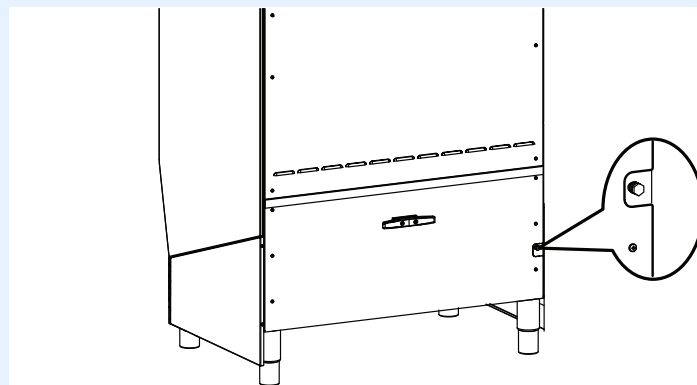

## Result

The merchandiser is now installed.

# How to Install the Skirt on a Floor Model Merchandiser

## Background

Merchandisers with casters include three skirt panels that need to be installed after the merchandiser is in position.

## Before you begin

**Make sure** you have basic hand tools.

## Procedure

To install the skirt to the floor model merchandiser, do the following.

Step	Action
1.	<b>Remove</b> the screws ①.
2.	<b>Slide</b> the front skirt panel ② into position and secure it with the screws removed in step 1.
3.	<b>Remove</b> the screws ③ from the rear of the merchandiser.
4.	<b>Slide</b> the side skirt ④ into position and secure it with the screws removed in step 3.
5.	<b>Repeat</b> for the other side skirt .

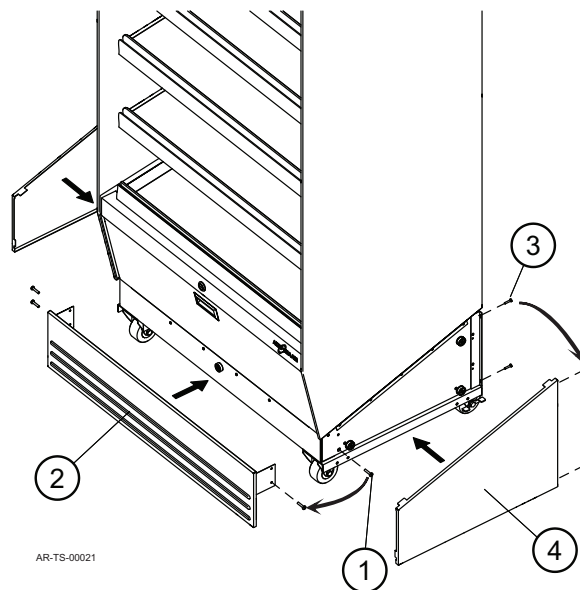

## Result

The skirt has been installed.

# How to Add a Display Base to an Existing Countertop Merchandiser

**Background** The optional base adds 8" (203mm) to the overall height of a countertop merchandiser.

**Before you begin** **Make sure** you have basic hand tools.  
**Make sure** you have an appropriate lifting device for the weight of the appliance. See topic *How to Unpack the Merchandiser* for appliance weights.

**Procedure** To install a display base to an existing countertop merchandiser, do the following:

Step	Action
1.	<b>Place</b> the merchandiser so that the bottom panel rests on a lifting device or platform set at a height of 12" (305mm).
2.	<b>Unscrew</b> the four legs ①.



*Continued on next page*

Continued from previous page

3. **Place** the display base frame ② next to the lifting device or platform.
  - If the display base has casters, make sure the brakes are set.
  - If the display base has legs, make sure they are set to a height of at least 4.33" (110mm).

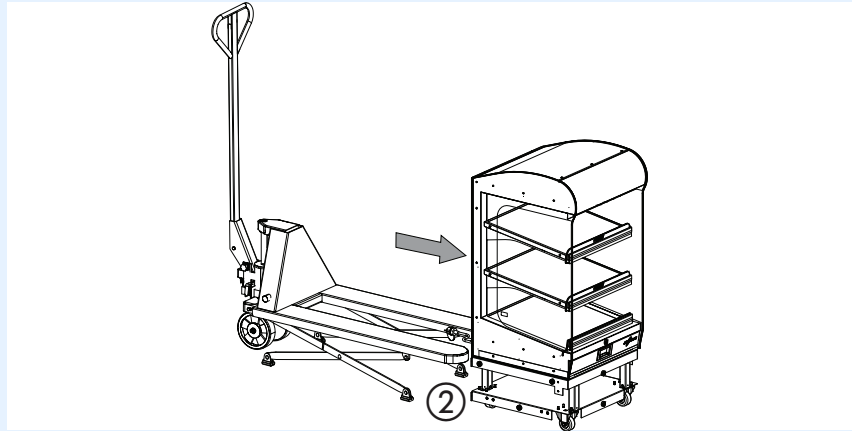

4. **Slide** the merchandiser onto the frame. Make sure all sides align with the frame.

5. **Use four SC-27441 screws ③** to secure the merchandiser to the display base.

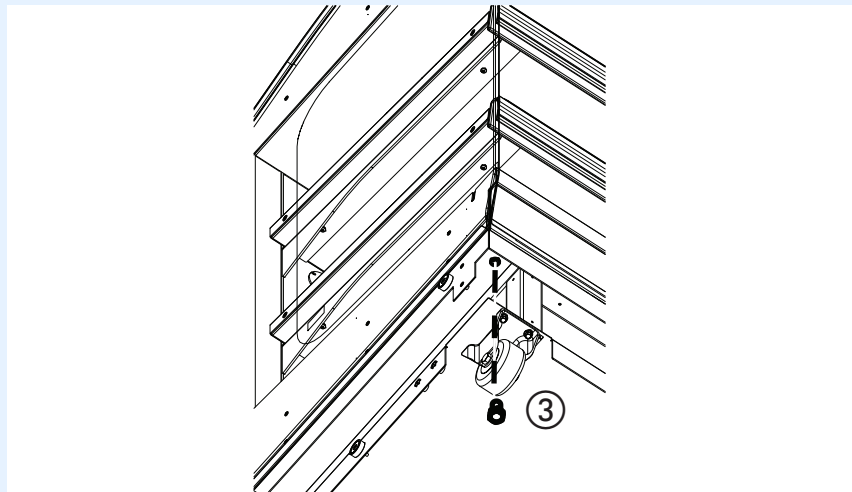

6. **Position** the merchandiser where it will be used.

Continued on next page

Continued from previous page

7. **Position** the front skirt panel so the holes in the side flanges ④ line up with the screw holes in the side of the display base. The magnet on the front of the display base holds the panel in place.

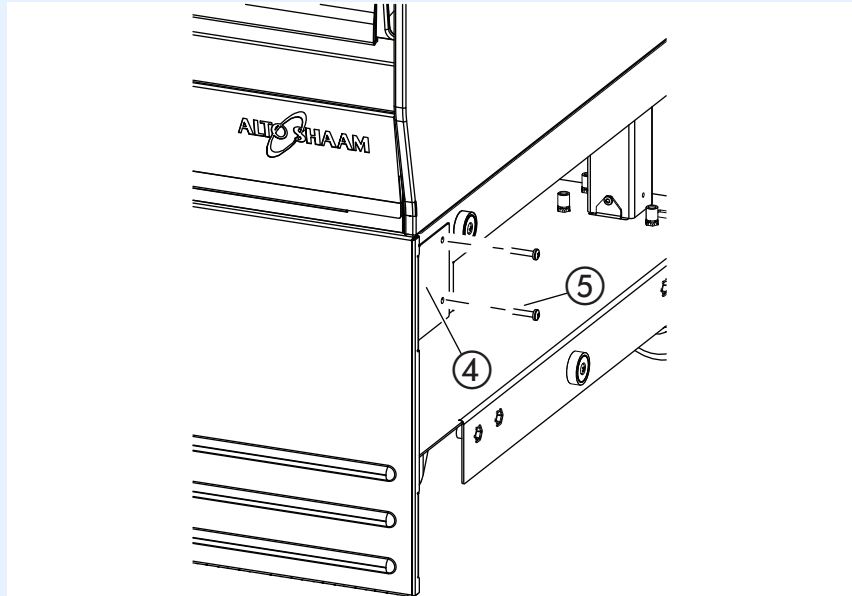

8. **Attach** the front panel to the display base with two screws ⑤ on each side.

9. **Slide** the flanges of the two side panels ⑥ into the slots in the front panel. The magnets ⑦ on the side of the display base hold the side panels in place.

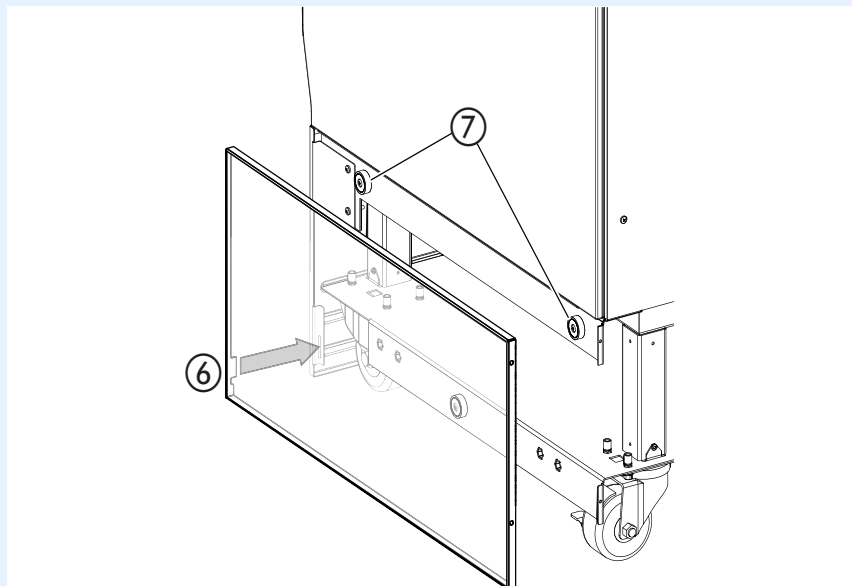

Continued on next page



Continued from previous page

10. **Attach** each side panel to the display base with two screws ⑧.

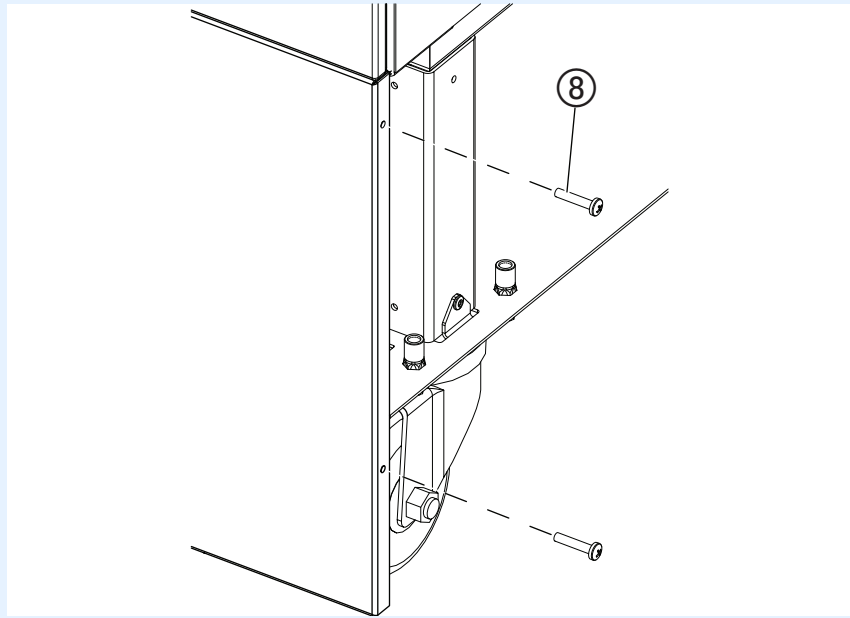

**Result**

The display base has been installed.

# How to Install the Optional Shelf Insert for Magnetic Signage Panels

## Background

The optional shelf insert allows magnetic signage panels to be used on the merchandiser shelves. The insert can be removed at any time.

## Procedure

To install the shelf insert, do the following.

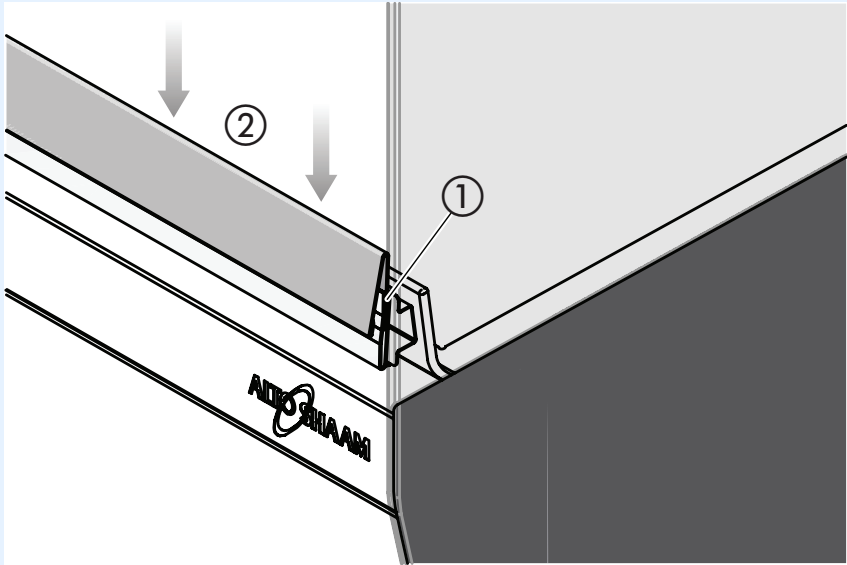
Step	Action
1.	<b>Open</b> the plastic shelf guard ① slightly.
	
2.	<b>Slide</b> the shelf insert ② down into the shelf guard until it sets firmly in place. <b>Release</b> the shelf guard.
3.	<b>Press</b> along the entire length of the insert to make sure it is fully seated. Make sure that the shelf guard holds the insert tightly in place.
4.	<b>Repeat</b> these steps for every shelf where you want to use magnetic signage panels.

## Result

The shelf insert has been installed.

# Shelf Capacities

---

The shelf capacity for a Heated Shelf Merchandiser differs depending on the configurations of the unit. The shelf capacities are as follows.

- **HSM-24/3S/T:** Three (3) 20-7/8" (530mm) width shelves, fifteen (15) sandwiches or six (6) chicken boats with dome cover per shelf.
- **HSM-24/5S/T:** Five (5) 20-7/8" (530mm) width shelves, fifteen (15) sandwiches or six (6) chicken boats with dome cover per shelf.
- **HSM-36/2S/T:** Two (2) 32-7/8" (835mm) width shelves, eight (8) chicken boats with dome cover per shelf.
- **HSM-36/3S/T:** Three (3) 32-7/8" (835mm) width shelves, eight (8) chicken boats with dome cover per shelf.
- **HSM-36/5S/T:** Five (5) 32-7/8" (835mm) width shelves, eight (8) chicken boats with dome cover per shelf.
- **HSM-48/5S/T:** Five (5) 44-7/8" (1140mm) width shelves, twelve (12) chicken boats with dome cover per shelf.

# How to Turn On and Turn Off the Merchandiser

## Before you begin

The merchandiser must be connected to electric power.

## Turning on the merchandiser

To turn on the merchandiser, do the following.

Step	Action
1.	<p><b>Locate</b> the power switch ① below the top canopy on the left side of the merchandiser.</p> <p><b>Press</b> the power switch to the ON position.</p>
	
	<p>The merchandiser is now on.</p>
2.	<p>To turn off the merchandiser, do the following.</p> <p><b>Locate</b> the power switch ① below the top canopy on the left side of the merchandiser.</p> <p><b>Press</b> the power switch to the OFF position.</p>
	<p>The merchandiser is now off.</p>

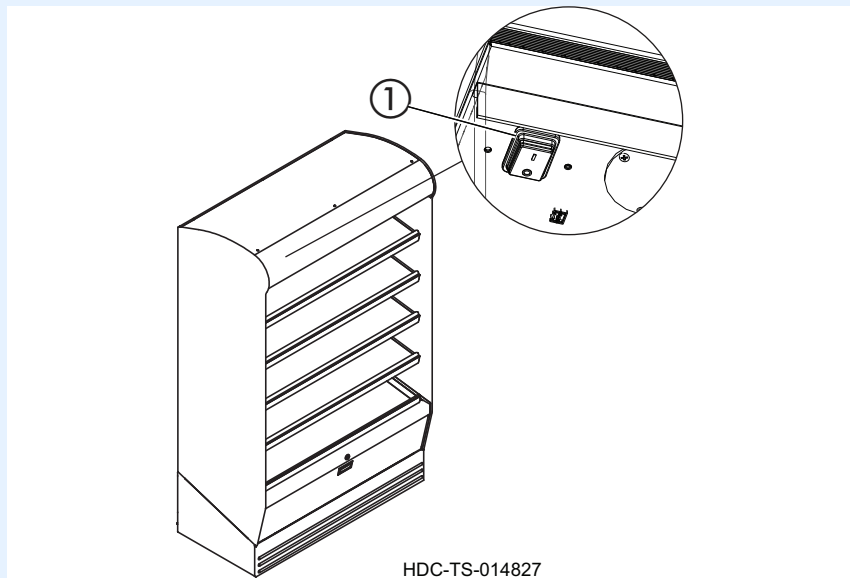

## Turning off the merchandiser



## Result

The merchandiser is now off.

# How to Prepare the Merchandiser for First Use

## Background

Use this procedure for initial use or before using the merchandiser after taking it out of storage.

## Procedure

To prepare the merchandiser for first use, do the following.

Step	Action
1.	<b>Remove</b> all packing material from the merchandiser.
2.	<b>Remove</b> and wash detachable items with hot, soapy water. Dry with a clean, damp, lint-free cloth.
3.	<b>Remove</b> visible grease or oil from the merchandiser.
4.	<b>Clean</b> the interior and exterior of the merchandiser with a mild soap and water solution. Apply the solution with a clean, damp cloth. Do not use commercial or household cleaners that contain ammonia. Wipe with a clean, damp cloth to remove all detergent residue. Dry with a clean, lint-free cloth.
5.	<b>Clean</b> the merchandiser glass with glass cleaner or distilled vinegar.
6.	<b>Operate</b> the merchandiser without food for a period of 15 minutes using setting 9 ( <i>See topic: How to Operate the Merchandiser</i> ) to remove surface oils and any accompanying odor.

## Result

The merchandiser is now ready for operation.

# How to Operate the Merchandiser

## Before you begin

- The merchandiser must be connected to electric power.
- Review the following general instructions:
  - Do not allow food or water to contact the shelves.
  - Use hand protection when handling hot items.
  - Place only hot items into the merchandiser.
  - Test your containers/packaging to be sure it performs as required and that it does not scratch the shelves. Do not use metal pans or ceramic dishes.
  - Do not stack the containers/packaging.

## Operating the merchandiser

To operate the merchandiser, do the following.

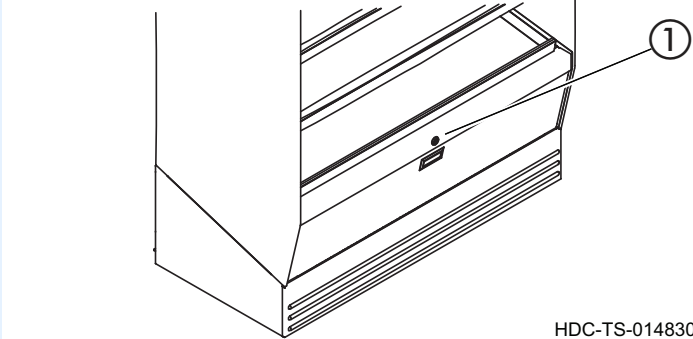
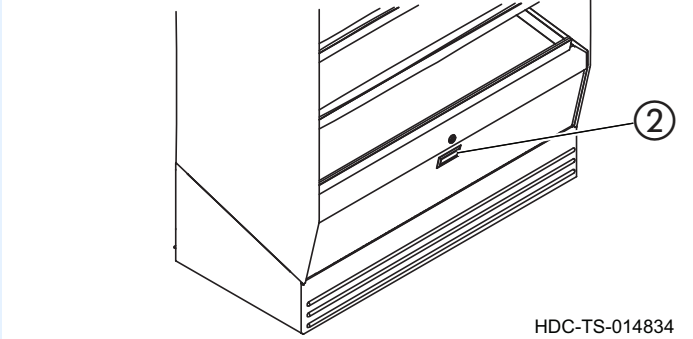
Step	Action
1.	<b>Turn on</b> the merchandiser. <b>See topic</b> <i>How to Turn On and Off the Merchandiser</i> .
2.	<b>Turn</b> the control panel door latch ① with a coin or flathead screwdriver.
 <p>HDC-TS-014830</p>	
3.	<b>Pull</b> the door open <b>using</b> the control panel door handle ②
 <p>HDC-TS-014834</p>	

*Continued on next page*

Continued from previous page

4. **Turn** the thermostat knob(s) ③ to 4.5–5 for units with doors or 5–6 for units without doors. **Preheat** the merchandiser. The time required to preheat the merchandiser depends on environmental factors.

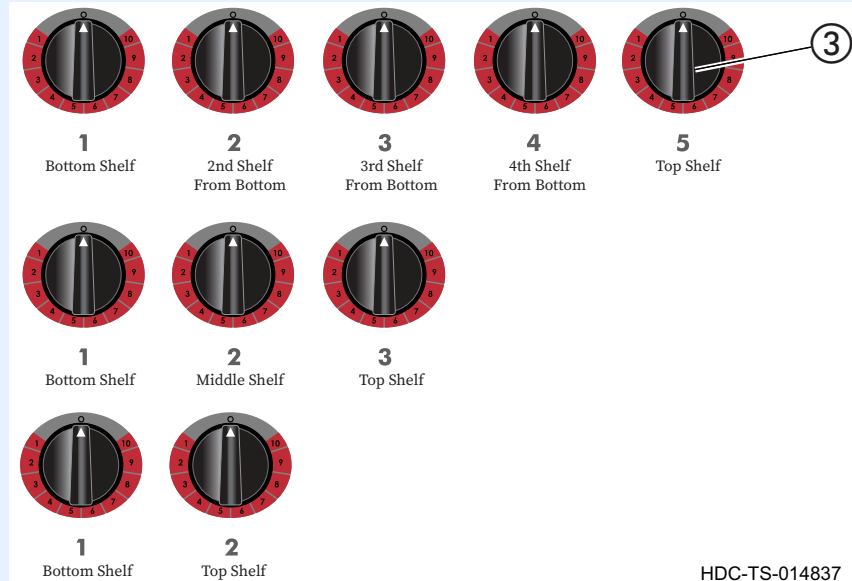

Each shelf has a thermostat control numbered from 1 to 10, with 10 being the hottest. When the thermostat is turned clockwise to the determined setting, the indicator light—found above each shelf—illuminates and remains illuminated as long as the shelf is being heated.

5. **Use** a thermometer to make certain all food products are hot and have been cooked thoroughly before loading food into the merchandiser.
6. **Load** pre-packaged hot foods into the merchandiser. Periodically **check** the internal temperature of each food item to ensure maintenance of the proper temperature range.

## Result

The merchandiser is now in operation.

This page is intentionally left blank.



# How to Clean the Merchandiser

## Before you begin



**WARNING:** Electric shock hazard.  
Set the power switch to the OFF position and unplug the merchandiser before cleaning it.



**CAUTION:** Burn hazard.  
Allow the merchandiser and racks to cool before cleaning.



**CAUTION:** Corrosive materials hazard.  
Wear eye protection and hand protection when cleaning.

**NOTICE**

Using improper cleaning procedures will damage the merchandiser and void the warranty.  
Only use spray cleaner when the electric power is completely removed from the merchandiser.  
Do not use steel pads, wire brushes, or scrapers when cleaning.

## Cleaning procedure

To clean the merchandiser, do the following.

Step	Action
1.	<b>Make sure</b> the merchandiser is turned off and cool. <b>Press</b> the On/Off switch to the OFF (O) position. <b>Disconnect</b> the merchandiser from the power source. Allow the merchandiser to cool.
2.	<b>Remove, cover or wrap</b> , and <b>store</b> food product under refrigeration.
3.	<b>Clean</b> the exterior of the merchandiser with a mild soap and water solution. Apply the solution with a clean, damp cloth. Do not use commercial or household cleaners that contain ammonia. Wipe with a clean, damp cloth to remove all detergent residue. Dry with a clean, lint-free cloth. Clean the exterior of the cabinet with a cleaner recommended for stainless steel surfaces to maintain the protective film coating on any polished stainless steel.
4.	<b>Clean</b> the anodized-aluminum shelves and other interior components with a mild soap and hot water.

*Continued on next page*

*Continued from previous page*

5. **Spray** heavily-soiled areas with a water-soluble degreaser and let stand for 10 minutes, then remove the soil with a plastic scouring pad.
6. **Wipe** the interior surfaces with a sanitizing solution after cleaning and rinsing. This solution must be approved for use on food contact surfaces.
7. **Clean** the merchandiser glass with glass cleaner or distilled vinegar.

Always follow appropriate state or local health (hygiene) regulations regarding all applicable cleaning and sanitation requirements for food service equipment.

## Result

The merchandiser is now clean.

# Warranty

## Introduction

Alto-Shaam, Inc. warrants to the original purchaser only, that any original part found to be defective in material or workmanship will be replaced with a new or rebuilt part at Alto-Shaam's option, subject to provisions hereinafter stated.

## Warranty Period

The original parts warranty period is as follows:

- For all other original parts, one (1) year from the date of installation of appliance or fifteen (15) months from the shipping date, whichever occurs first.
- The labor warranty period is one (1) year from the date of installation or fifteen (15) months from the shipping date, whichever occurs first.
- Alto-Shaam will bear normal labor charges performed during standard business hours, excluding overtime, holiday rates or any additional fees.
- For the refrigeration compressor, if installed, the warranty period is five (5) years from the date of original installation of the appliance.
- For heating elements on Halo Heat® Cook and Hold ovens, the warranty period is for as long as the original owner owns the oven. This warranty period applies to units sold after 2/1/2009 and excludes holding-only ovens.
- To be valid, a warranty claim must be asserted during the applicable warranty period. This warranty is not transferable.

## Exclusions

This warranty does not apply to:

- Calibration.
- Replacement of light bulbs, rubber gaskets, grease filters, air filters, racks, jet plates, and/or the replacement of glass due to damage of any kind.
- Equipment damage caused by accident, shipping, improper installation or alteration.
- Equipment used under conditions of abuse, misuse, carelessness or abnormal conditions, including but not limited to, equipment subjected to harsh or inappropriate chemicals, including but not limited to, compounds containing chloride or quaternary salts, poor water quality, or equipment with missing or altered serial numbers.
- Equipment damage caused by use of any cleaning agents other than those recommended by Alto-Shaam, including but not limited to damage due to chlorine or other harmful chemicals.
- Any losses or damage resulting from malfunction, including loss of food product, revenue, or consequential or incidental damages of any kind.
- Equipment modified in any manner from original model, substitution of parts other than factory authorized parts, unauthorized removal of any parts including legs, or unauthorized addition of any parts.

*Continued on next page*

*Continued from previous page*

- Equipment damage incurred as a direct result of poor water quality\*, inadequate maintenance of steam generators and/or surfaces affected by water. Water quality and required maintenance of steam generating equipment is the responsibility of the owner/operator.
  - Equipment damage incurred as a result of not following the required maintenance schedule published in the manuals for the equipment.
- 

## **Conclusion**

This warranty is exclusive and is in lieu of all other warranties, express or implied, including the implied warranties of merchantability and fitness for a particular purpose. No person except an officer of Alto-Shaam, Inc. is authorized to modify this warranty or to incur on behalf of Alto-Shaam any other obligation or liability in connection with Alto-Shaam equipment.

*\*Refer to the product spec sheet for water quality standards.*

# DECLARATION OF CONFORMITY

**Manufacturer:**  
Alto-Shaam, Inc.  
W164 N9221 Water Street  
Menomonee Falls, WI 53202-0450

**ALTO-SHAAM.**

**EQUIPMENT TYPE:** Household and Similar Electric Appliances

**EQUIPMENT DESCRIPTION:** Heated Display Case

**MODEL NUMBER:** HSM-24, 36 or 48, W Shelves 3S, 4S or 5S  
W/WO Suffixes T and/or PT, CT

**APPLIED DIRECTIVES:** Low Voltage Directive 2014/35/EU  
MD (Machinery Directive) 2006/42/EC  
EMC – 2014/30/EC  
RoHS – 2011/65/EU  
WEEE – 2012/19/EU

**APPLIED STANDARDS:** EN 60335-1:  
2012+A11:2014=A13:2017+A1:2019+  
A2:2019+A14:2019  
EN 60335-2-49:2003 + A1:2008 +  
A11:2012+A2:2019  
EN 55014-1: CISPR 14, EN 55014-2: CISPR 14



*We the undersigned, hereby declare that the equipment specified above conforms to the above Directives and Standards*

Manufacturer Name:  
**ALTO-SHAAM INC.**  
**NAME:** Christa Pieper  
**TITLE:** Certification Manager

**SIGNATURE:**   
**DATE:** July 19<sup>th</sup> 2022



DECLARATION OF CONFORMITY

# DECLARATION OF CONFORMITY

**Manufacturer:**  
Alto-Shaam, Inc.  
W164 N9221 Water Street  
Menomonee Falls, WI 53202-0450



**EQUIPMENT TYPE:** Household and Similar Electric Appliances

**EQUIPMENT DESCRIPTION:** Heated Display Case

**MODEL NUMBER:** HSM-24/3S, 4S or 5S W/WO Suffix PT and /or CT or PB  
HSM-36/3S, 4S or 5S W/WO Suffix PT and /or CT or PB  
HSM-48/3S, 4S or 5S W/WO Suffix PT and /or PB

**APPLIED UK REGULATIONS:**

- Electrical Equipment (Safety) Regulations 2016
- Electromagnetic Compatibility Regulations 2016
- The Restriction of the Use of Certain Hazardous Substances in Electrical and Electronic Equipment Regulations 2012
- The Eco design for Energy-Related Products and Energy Information (Amendment) (EU Exit) Regulations 2019

**APPLIED STANDARDS:**

EN 60335-1:2012  
EN 60335-2-36:2002 + A1:2004 + A2:2008 + A11:2012  
EN 55014-1:2018, EN 55014-2:2016



*We the undersigned, hereby declare that the equipment specified above conforms to the above Directives and Standards*

Manufacturer Name:  
**ALTO-SHAAM INC.**  
**NAME:** Christa Pieper  
**TITLE:** Certification Manager



**SIGNATURE:**   
**DATE:** July, 21<sup>st</sup> 2021





# ALTO-SHAAM.

Menomonee Falls, WI U.S.A.

Phone 800-558-8744 | +1-262-251-3800 | alto-shaam.com

## ASIA

Shanghai, China  
Phone +86-21-6173-0336

## AUSTRALIA

Brisbane, Queensland  
Phone 800-558-8744

## CANADA

Concord, Ontario Canada  
Toll Free Phone 866-577-4484  
Phone +1-905-660-6781

## FRANCE

Aix en Provence, France  
Phone +33(0)4-88-78-21-73

## GMBH

Bochum, Germany  
Phone +49 (0)234 298798-0

## ITALY

Padua, Italy  
Phone +39 3476073504

## INDIA

Pune, India  
Phone +91 9657516999

## MEXICO

Phone +52 1 477-717-3108

## MIDDLE EAST & AFRICA

Dubai, UAE  
Phone +971-4-321-9712

## CENTRAL & SOUTH AMERICA

Miami, FL USA  
Phone +1 954-655-5727

## RUSSIA

Moscow, Russia  
Phone +7 903 7932331