

Prodigi™

Pro Control and Classic Control

6-10E	6-10G
10-10E	10-10G
7-20E	7-20G
10-20E	10-20G
20-10E	20-10G
20-20E	20-20G



MN-48109-EN

REV.02
06/23

EN

For the most current manual, visit alto-shaam.com
Die neueste Fassung des Handbuchs finden Sie auf alto-shaam.com
Pour la dernière version du manuel, visitez alto-shaam.com
Para obtener el manual más actual, visite alto-shaam.com
Ga voor de meest recente handleiding naar alto-shaam.com
За самой последней версией руководства обращайтесь на сайт alto-shaam.com
要查看当前最新手册，请访问 alto-shaam.com



Manufacturer's Information

Copyright

© Copyright 6/23 by Alto-Shaam, Inc.

All rights reserved.

This manual or any portion thereof may not be reproduced or used in any manner whatsoever without the express written permission of Alto-Shaam, Inc.

Trademarks

All trademarks referenced in this documentation are the property of their respective owners.

Manufacturer

Alto-Shaam, Inc.

P.O. Box 450

W164 N9221 Water Street

Menomonee Falls, WI 53052

Original instructions

The content in this manual is written in American English.



DANGER: Before starting the oven, make sure you do not detect the odor of gas.

If you smell gas:

- Shut off the gas supply immediately.
- Do not attempt to light any appliance.
- Do not touch any electrical elements.
- Extinguish any open flame.
- Evacuate the area.
- Use a telephone outside of the property and immediately contact your gas supplier.
- If unable to contact your supplier, contact the fire department.

Extend Your Manufacturer's Warranty

Register

Register your Alto-Shaam appliance online. Registering your appliance ensures prompt service in the event of a warranty claim.

Your personal information will not be shared with any other company.

alto-shaam.com/warranty

Alto-Shaam 24/7 Emergency Repair Service

Call

Call 800-558-8744 to reach our 24-hour emergency service call center for immediate access to local authorized service agencies outside standard business hours. The emergency service access is provided exclusively for Alto-Shaam equipment and is available throughout the United States through Alto-Shaam's toll free number.

Availability

Emergency service access is available seven days a week, including holidays.

This page is intentionally left blank.

Manufacturer’s Information 2

Foreword 3

 Extend Your Manufacturer’s Warranty 3

 Alto-Shaam 24/7 Emergency Repair Service 3

Table of Contents 5

Safety 7

 The Meaning of Signal Words 7

 Safety Precautions. 8

Installation 11

 How to Unpack the Oven 11

 ChefLinc Installation Checklist 12

 How to Install the Oven on a Stand 14

 How to Position the Oven 15

 How to Connect the Wiring. 16

 Electrical Kit Installation—50 Hz 21

 Electrical Kit Installation—60 Hz 22

 How to Install the Gas Connections. 23

 How to Install the Water Supply 25

 How to Install the Water Drain. 28

 How to Install the Liquid Cleaner (if equipped) 33

 How to Install the Grease Collection System (if equipped) 34

Operation 37

 How to Turn On and Turn Off the Oven 37

 Post-Installation Checklist 38

Troubleshooting 39

 Error Codes. 39

TABLE OF CONTENTS

This page is intentionally left blank.

The Meaning of Signal Words

This manual contains signal words where needed. These signal words must be obeyed to reduce the risk of death, personal injury, or equipment damage. The meaning of these signal words is explained below.

**DANGER**

Danger indicates a hazardous situation which, if not avoided, will result in serious injury or death.

**WARNING**

Warning indicates a hazardous situation which, if not avoided, could result in serious injury or death.

**CAUTION**

Caution indicates a hazardous situation which, if not avoided, could result in minor or moderate injury.

NOTICE

Notice indicates a situation which, if not avoided, could result in property damage.



NOTE: Note indicates additional information that is important to a concept or procedure.

Safety Precautions

Before you begin

Read and understand all instructions in this manual.

Electrical precautions

Obey these electrical precautions when using the appliance:

- All electrical connections must be made by a qualified and trained service technician in accordance with applicable electrical codes.
 - Consult local codes and Specification Sheets for the electrical cable and breaker size.
 - Power source must match voltage identified on appliance tag.
 - CE-approved appliances include an equipotential-bonding terminal marked with the equipotential symbol.
 - For CE models, use a Type B current protection device that accommodates a leakage current of 30mA.
-

Gas precautions

Obey these gas precautions when using the appliance:

- Only use the oven when the exhaust hood is turned on.
 - Keep the area around the oven clear of any obstructions that might slow down the flow of cooling air.
 - Do not place objects near the oven's exhaust vents.
 - Do not touch the exhaust vents while the oven is running or immediately after it has been turned off.
 - Do not spray aerosols in the area of the oven during operation.
 - Do not store flammable materials in the area of the oven.
-

Usage precautions

Obey these usage precautions when using the appliance:

- Only use this appliance for its intended use of heating or cooking food.
- Always keep liquids, or foods that can become liquid when heated, level and at or below eye level where they can be seen.
- Use utensils and protective clothing such as dry oven mitts when loading and unloading the appliance.
- Use caution when using the appliance. Floors adjacent to the appliance may become slippery.
- If the appliance is installed on casters, freedom of movement of the appliance must be restricted so that utility connections (including gas, water, and electricity) cannot be damaged when the appliance is moved. If the appliance is moved, make sure that all utility connections are properly disconnected. If the appliance is returned to its original position, make sure that any retention devices and utility connections are properly connected.

Continued on next page

Continued from previous page

- Do not cover or block any of the openings of this appliance.
- Do not cover racks or any other part of this appliance with metal foil.
- Do not keep anything underneath the oven that could block the vents.
- Do not use this appliance near water such as a sink, in a wet location, near a swimming pool, or similar locations.

Maintenance precautions

Obey these maintenance precautions when maintaining the appliance:

- Obey precautions in the manual, on tags, and on labels attached to or shipped with the appliance.
- Only clean the exterior of the appliance when oven is OFF.
- Do not store the appliance outdoors.
- Do not clean the appliance with metal scouring pads.
- Do not use corrosive chemicals when cleaning the appliance.
- Do not use a hose or water jet to clean the appliance.
- Do not use the appliance cavity for storage.
- Do not leave flammable materials, cooking utensils, or food inside the appliance when it is not in use.
- Do not remove the top cover or side panels. There are no user-serviceable components inside.

Operator training

Before using the appliance:

- Read and understand the operating instructions contained in all the documentation delivered with the appliance.
- Know the location and proper use of all controls.
- Keep this manual and all supplied instructions, diagrams, schematics, parts lists, notices, and labels with the appliance if the appliance is sold or moved to another location.
- Contact Alto-Shaam for additional training if needed.

Operator qualifications

Only trained personnel are permitted to use the appliance. They must meet the following qualifications:

- Have received proper instruction on how to use the appliance
- Are familiar with commercial kitchens and commercial appliances

The appliance must not be used by:

- Persons (including children) with reduced physical, sensory or mental capabilities, or lack of experience and knowledge, unless they have been given supervision concerning use of the appliance by person responsible for their safety.
- People impaired by drugs or alcohol.

Continued on next page

Continued from previous page

- Children should be supervised to ensure that they do not play with the appliance.
- Children shall neither clean nor maintain the appliance.

Condition of appliance

Only use the appliance when:

- All controls operate correctly
- The appliance is installed correctly
- The appliance is clean
- The appliance labels are legible

Servicing the appliance

- Only trained personnel are permitted to service or repair the appliance. Repairs that are not performed by an authorized service partner or trained technician, or the use of non-factory parts, will void the warranty and relieve Alto-Shaam of all liability.
- To prevent serious injury, death or property damage, have the appliance inspected and serviced at least every twelve (12) months by an authorized service partner or trained technician.
- Contact Alto-Shaam for the authorized service partner in your area.

Sound power

The A-weighted sound pressure level is below 72 dB(A).

Personal Protective Equipment (PPE)

Wear the following Personal Protective Equipment (PPE) while cleaning the appliance:

- Protective gloves
- Protective clothing
- Eye protection
- Face protection



DANGER: Before starting the oven, make sure you do not detect the odor of gas.

If you smell gas:

- Shut off the gas supply immediately.
- Do not attempt to light any appliance.
- Do not touch any electrical elements.
- Extinguish any open flame.
- Evacuate the area.
- Use a telephone outside of the property and immediately contact your gas supplier.
- If unable to contact your supplier, contact the fire department.

How to Unpack the Oven

Before you begin

Make sure you have:

- An appropriate lifting device and enough personnel to safely move and position the weight of the oven. See Specification Sheet for the weight of the oven.
- Cutting tools to remove the packaging.

Unpack the oven

To unpack the oven, do the following.

Step	Action
1.	Remove the box. Save all packing materials for inspection by the carrier.
	<div style="border: 1px solid black; padding: 5px;"> <p> NOTE: Examine the appliance for damage. If the appliance has been damaged, do not use the appliance until it has been inspected by an authorized service provider. Contact your carrier or Alto-Shaam customer service.</p> </div>
2.	Remove the plastic wrap.
3.	Cut the retaining straps.
4.	Remove the oven from the pallet using an appropriate lifting device.
5.	Remove the foam and paperwork from the cavity of the oven.
6.	Remove the protective paper from the outside of the oven.

Result

The oven is now unpacked.

ChefLinc Installation Checklist

Place this form with the oven's records.

Connectivity Pre-Installation Checklist

Will you connect the oven to the Internet using Wi-Fi or Ethernet?	Wi-Fi	Ethernet	Unable to answer
--	-------	----------	------------------

Wi-Fi Connections

Is the Wi-Fi network that is to be used a WPA2 secured network?	Yes	No	Unable to answer
Is this network also used to send and receive point of sale information (credit card data, register receipts)? This is NOT recommended for any installation.	Yes	No	Unable to answer
Have you been provided with the network name (SSID) for the oven to connect to?	Yes	No	Unable to answer
Have you been provided the password for the Wi-Fi network to be used?	Yes	No	Unable to answer
At the final location that the oven will be installed, can you connect to the Wi-Fi system with your phone?	Yes	No	Unable to answer
Using your phones Wi-Fi connection, are you able to connect to alto-shaam.com? You are testing for any additional security on the network to block access to external sites. You will need to turn off your cellular service on your phone to make sure you're using the Wi-Fi network.	Yes	No	Unable to answer

Ethernet Connections

At the final location that the oven will be installed, is there an open Ethernet port conveniently located?	Yes	No	Unable to answer
Is the Ethernet port live (providing Internet access)?	Yes	No	Unable to answer
Is the Ethernet harness accessory ordered with the unit?	Yes	No	Unable to answer

Is there site action required?	Yes	No
--------------------------------	-----	----

Action required:

Continued on next page

Continued from previous page

Connectivity Installation Checklist

Refer to Network Status screen

What is your connection type?	Wi-Fi	Ethernet
What color is the network status icon?	Red Yellow	Green
What is the Internet status?	Connected	Not connected
What is the cloud status?	Connected	Not connected
What is the update server status?	Connected	Not connected
What is the SSID (network name)?		
What is the password?		
What is the IP address?		
What is the Front End (FE) software version number?		
What is the Back End (BE) software version number?		
What is the Control Board (CB) software version number?		
Is this the latest software version?	Yes	No
Validate via: https://www.alto-shaam.com/en/customer-support/software-downloads		

How to Install the Oven on a Stand



Before you begin

Make sure you have:

- The appropriate stand for your oven
- Regulation UL 197, 91.8
- An appropriate lifting device and enough personnel to safely move and position the weight of the oven. See Specification Sheet for the weight of the oven.

Procedure

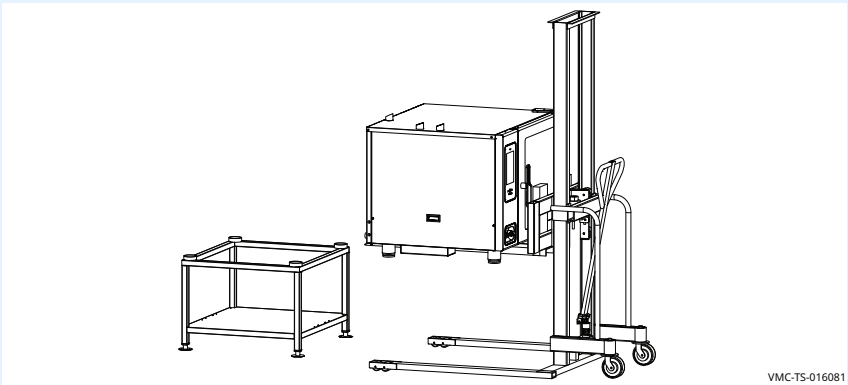
To install the oven on a stand, do the following.

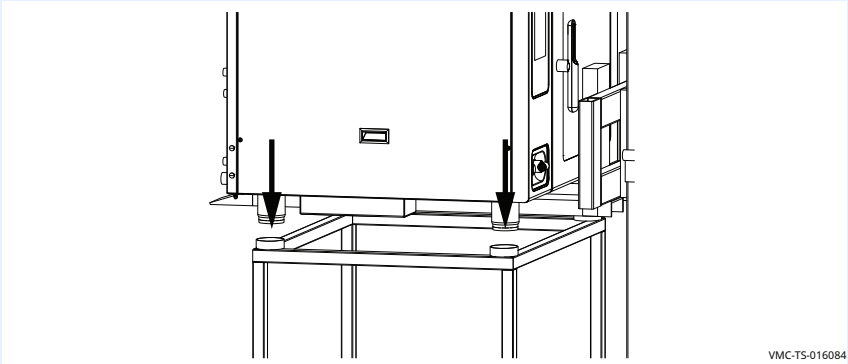
Step	Action
1.	<p>Lift the oven. Make sure to not damage the components on the bottom of the oven with the forks.</p> <div style="text-align: right; font-size: small;">VMC-TS-016081</div> 
2.	<p>Lower the oven onto the stand. Make sure the legs fit into the pockets on the stand.</p> <div style="border: 1px solid orange; padding: 5px; margin: 10px 0;">  <p>CAUTION: Crushing hazard. Lock the casters of the stand if equipped to prevent the oven from moving during installation.</p> </div> <div style="text-align: right; font-size: small;">VMC-TS-016084</div> 

Result

The oven is now installed on the stand.

How to Position the Oven

Before you begin

Make sure you have an appropriate lifting device and enough personnel to safely move and position the weight of the oven. See Specification Sheet for the weight of the oven.

Requirements

- The oven must be installed on a level surface.
- The oven must not be installed in any area where it may be affected by steam, grease, dripping water, high temperature, or any other severely adverse conditions.
- The oven is not intended for built-in installation.

Position the oven

To position the oven, do the following.

Step	Action
1.	<p>Make sure that:</p> <ul style="list-style-type: none"> ■ The location where the oven is being installed is rated to support the weight of the oven, ■ The oven is within five feet of the appropriate electrical source, ■ You follow the oven clearance guidelines. Refer to the Specification Sheet for the clearance requirement.
2.	<p>Move the oven to the installation location and onto the final resting surface.</p>

Result

The oven is now correctly positioned.

How to Connect the Wiring



WARNING: Electric shock hazard.

This procedure to be done only by qualified personnel familiar with local electrical codes.



WARNING: Electric shock hazard.

Appliances without a cord provided by the factory must be equipped with a cord of sufficient length to permit the appliance to be moved for cleaning.

Always use the correct AWG/IEC wire size based on the electrical requirements for the appliance.



WARNING: Electric shock hazard.

To prevent serious injury, death, or property damage:

All electrical connections must be made by a qualified and trained service technician in accordance with applicable electrical codes.

This appliance must be adequately grounded in accordance with local electrical codes or, in the absence of local codes, with the current edition of the National Electrical Code ANSI/NFPA No 70. In Canada, all electrical connections are to be made in accordance with CSA C22 1, Canadian Electrical Code Part 1 or local codes.

CE-approved appliances include an equipotential-bonding terminal marked with the equipotential symbol. Provisions for earthing are to be made in accordance with IEC: 60335-1 section 27 or local codes.



WARNING: Electric shock hazard.

Power source must match voltage identified on appliance rating tag. The rating tag provides essential technical information required for any appliance installation, maintenance or repairs. Do not remove, damage or modify the rating tag.

Hard-wired models:

Hard-wired models must be equipped with a country-certified, external, all-pole disconnection switch with sufficient contact separation. Hard-wired models that are mounted on casters must have a strain relief device (tether) to prevent strain on the power supply cord. If a power cord is used for the connection of the product, an oil resistant cord like H05RN or H07RN or equivalent must be used.

NOTICE

Where local codes and CE regulatory requirements apply, appliances must be connected to an electrical circuit that is protected by an external GFCI outlet.

Continued on next page

Continued from previous page

Before you begin

Make sure you have:

- Screwdriver (Phillips #2)
- Nut driver (1/4-inch)

Connect the wiring

To connect the wiring, do the following.

Step	Action
1.	Remove the side panel ①.



WARNING: Electric shock hazard.

Make sure the supply cord is not connected to the power source.

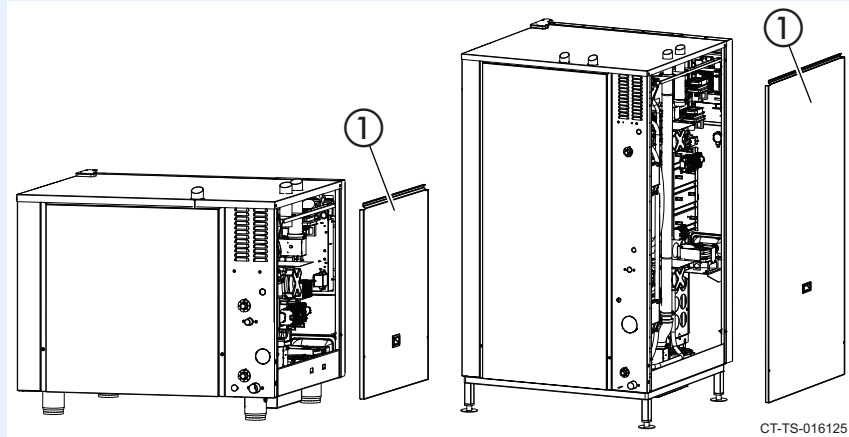

- | | |
|----|---|
| 2. | Locate the electrical knockouts ②. Determine which knockout is the correct size and remove the knockout. The oven can be wired using either access location. |
|----|---|

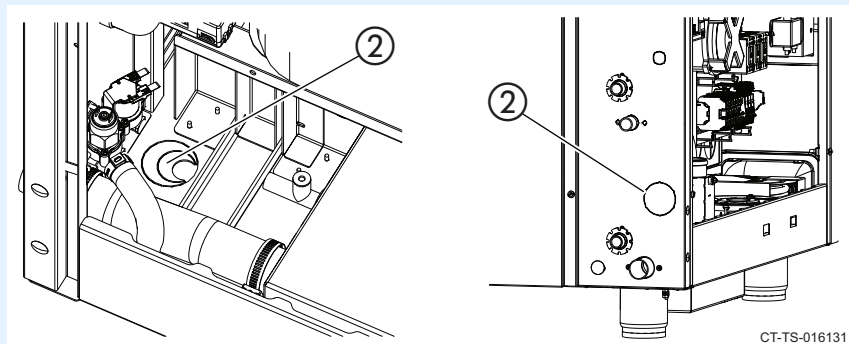

Continued on next page

Continued from previous page

3. **Locate** the main terminal blocks in the oven ③.

i **NOTE:** Your oven model may vary from the image.

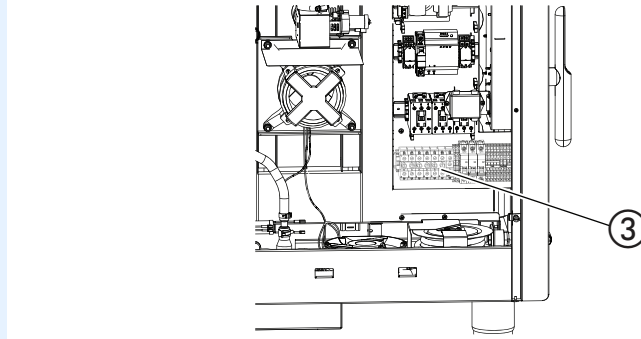

CT-TS-016134

4. **Insert** the cord grip ④.

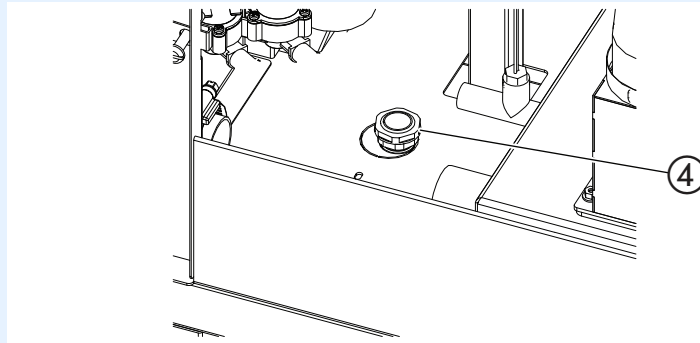

CT-TS-016137

5. **Slide** the supply cord ⑤ through the cord grip.

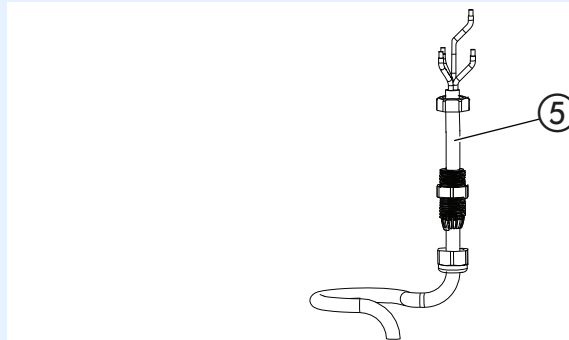

CT-TS-016140

Continued on next page

Continued from previous page

6. **Install** the supply cord into the oven far enough to reach the ground terminal block.

Connect the wires to the appropriate terminals (L1, L2, L3, etc.) ⑥ in accordance with local codes and regulations. **Install** the ground wire ⑦ to the ground terminal.

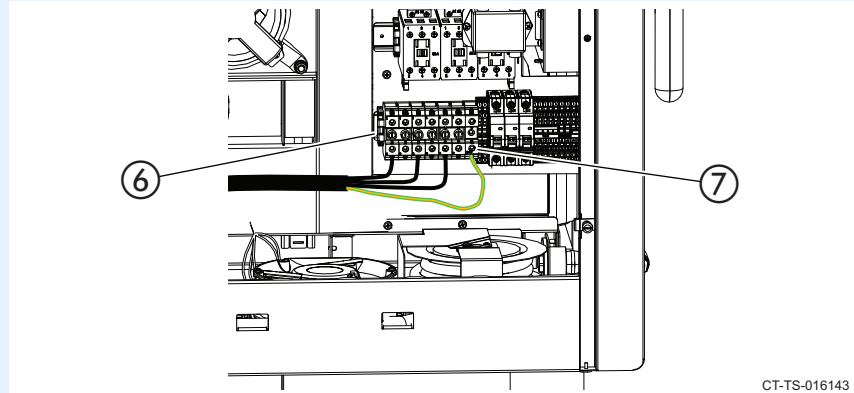

CT-TS-016143

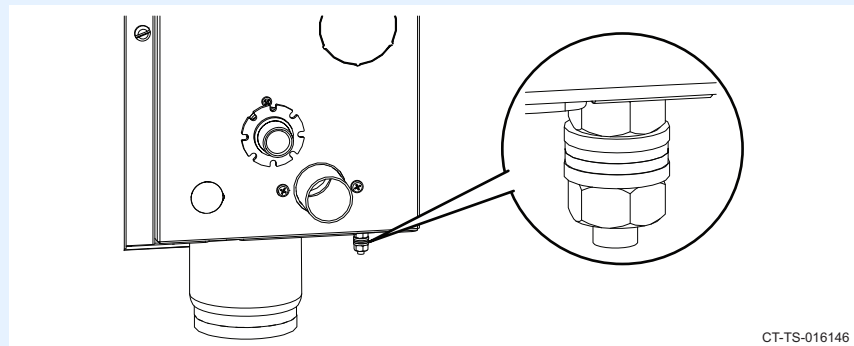

CT-TS-016146

i **NOTE:** Where bonding is required, the equipotential-bonding terminal is located at the bottom rear of the oven.

7. **Tighten** the cord grip sealing nut onto the supply cord.

Continued on next page

Continued from previous page

8. **Press and release** the high limit temperature reset button ⑧.

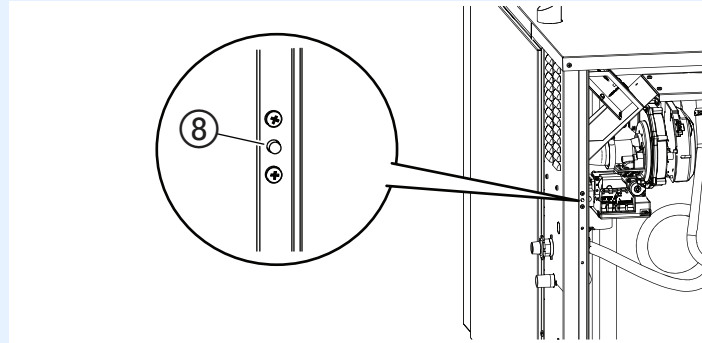

CT-TS-016149

9. **Re-install** the side panels.
10. **Connect** the supply cord to the power supply.

Result

The electrical connections are now installed.

Electrical Kit Installation—50 Hz

International Applications

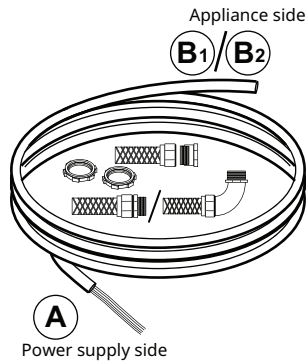

1

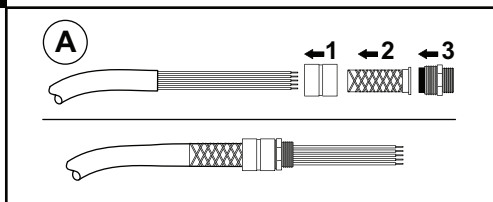

2

Remove enough cable covering so that wires reach the terminal blocks. Depending on the application, install the straight or the elbow fitting on to the cable.

Cut threads into nut before installing fitting. To do so, apply a light lubricant and thread nut on and off fitting.

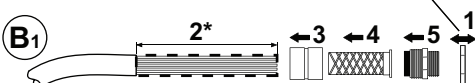

Cut threads into nut before installing fitting. To do so, apply a light lubricant and thread nut on and off fitting.

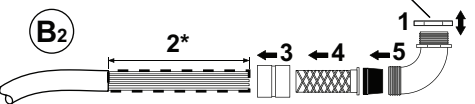

3

Install the fitting/wiring to the oven. Match the cable bushing to the correct sized knockout, remove the knockout.

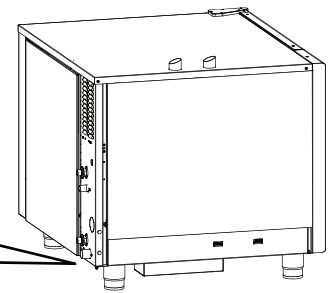
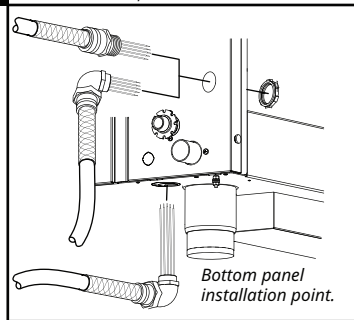

4

Route the wires. Keep wires away from hot surfaces such as water tank, drain pipe, motor, edges of sheet metal, vent pipes, or other appliances.

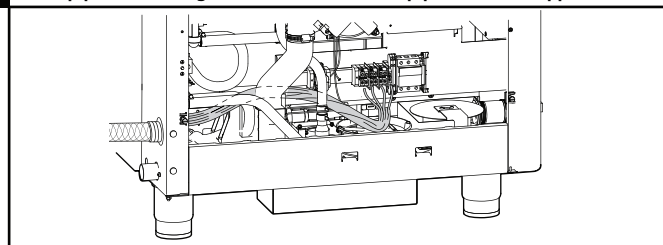

CT-TS-016425

Electrical Kit Installation—60 Hz

Applications for the Americas

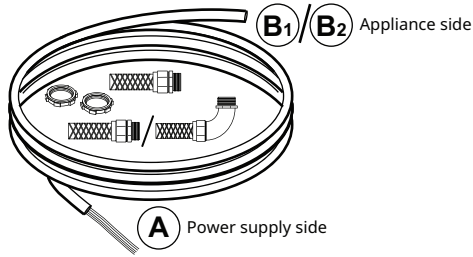

Note: Cabling and connectors must be supplied for 120V configurations.

1

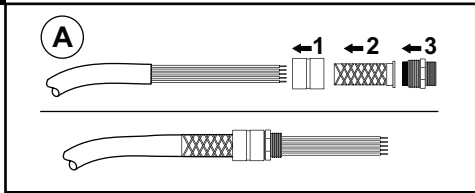

2

Remove enough cable covering so that wires reach the terminal blocks. Depending on the application, install the straight or the elbow fitting on to the cable.

Cut threads into nut before installing fitting. To do so, apply a light lubricant and thread nut on and off fitting.

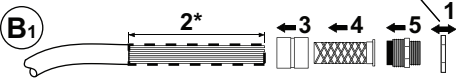

* For 3-phase appliances remove white wire.
* For 1-phase appliances remove red wire and orange wire.

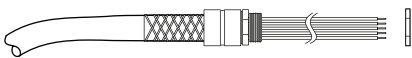

Cut threads into nut before installing fitting. To do so, apply a light lubricant and thread nut on and off fitting.

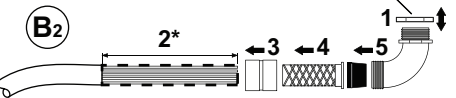

* For 3-phase appliances remove white wire.
* For 1-phase appliances remove red wire and orange wire.

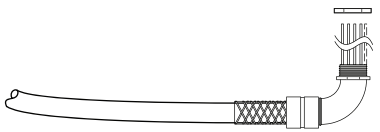

3

Install the fitting/wiring to the oven. Match the cable bushing to the correct sized knockout. Remove the knockout.

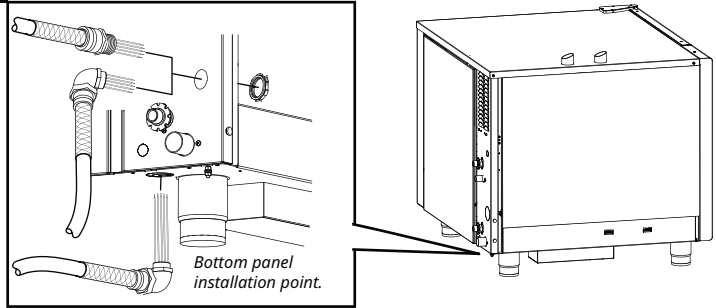

4

Route the wires. **Keep wires away from hot surfaces such as water tank, drain pipe, motor, edges of sheet metal, vent pipes, or other appliances.**

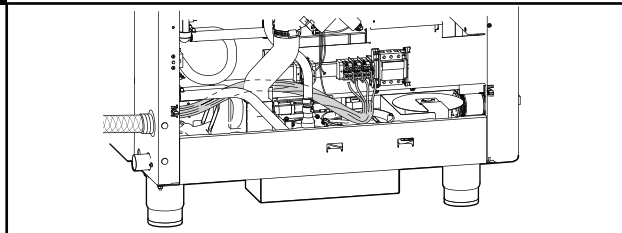

5

Connect the wires to the appropriate terminals (L1, L2, L3, etc.) in accordance with local codes and regulations. Install the ground wire to the ground terminal.

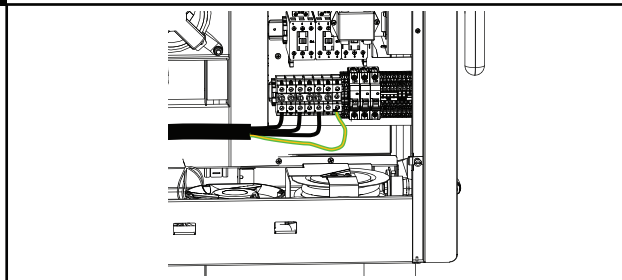

CT-TS-016428

How to Install the Gas Connections



DANGER: Carbon monoxide hazard.
ALWAYS operate the oven under a ventilation hood.



WARNING: Explosion hazard.
Do not operate the oven if you detect the odor of gas.

Installation, adjustments, and service work must be in accordance with all local codes and must be performed by a trained service technician.

Before you begin

Make sure you have:

- Pipe wrenches, gas-rated thread sealant

Ventilation requirements

- The single gas oven requires a minimum of 28 CFM (793 LPM) make-up air for both natural gas and propane gas.
- The gas supply piping and the electrical supply cord must be routed away from the path of the hot combustion fumes.
- The oven must be installed under a ventilation hood that complies with local regulations and relevant codes. In the absence of local codes, the ventilation system shall comply with:
 - USA and Canada: NFPA 96
 - EU: EN203

Gas supply requirements

- Only connect the type of gas indicated on the identification nameplate.
- Installation must comply with local codes required for gas ovens. In the absence of local codes, installation must comply with the latest edition of:
 - USA: National Fuel Gas Code, ANSI Z223.1 (NFPA 54).
 - Canada: Natural Gas and Propane Installation Code, CAN/CSA-B149.1-15.
- Gas connection: 3/4" NPT
- If a flexible gas line is used, it must be AGA approved, commercial type and at least 3/4" I.D.

Tether requirements for ovens on casters

- For ovens on casters, a tether must be installed. Install the tether so that no stress is transmitted to the gas or electrical connections when the oven moves.

Continued on next page

Continued from previous page

Installing gas connections

To install the gas connections, do the following.

Step	Action
------	--------

- | | |
|----|--|
| 1. | <p>Make sure the gas supply line has a shutoff valve installed ①.</p> <p>Assemble the sediment trap ②.</p> |
|----|--|

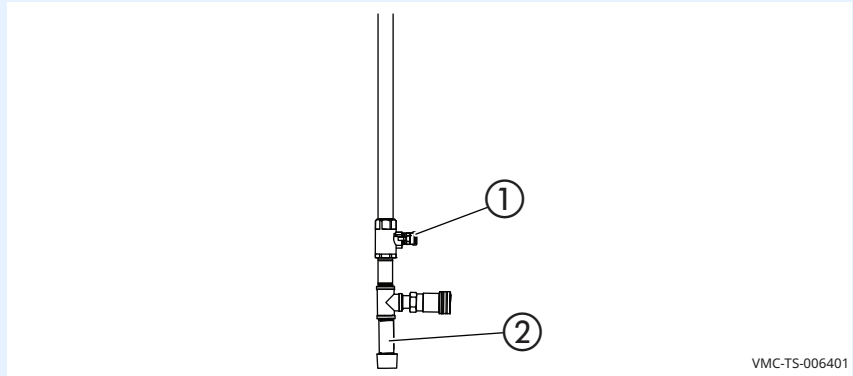

- | | |
|----|---|
| 2. | <p>Install the fitting ③ to the oven.</p> <p>Install the flexible connector ④ to the fitting ③.</p> |
|----|---|

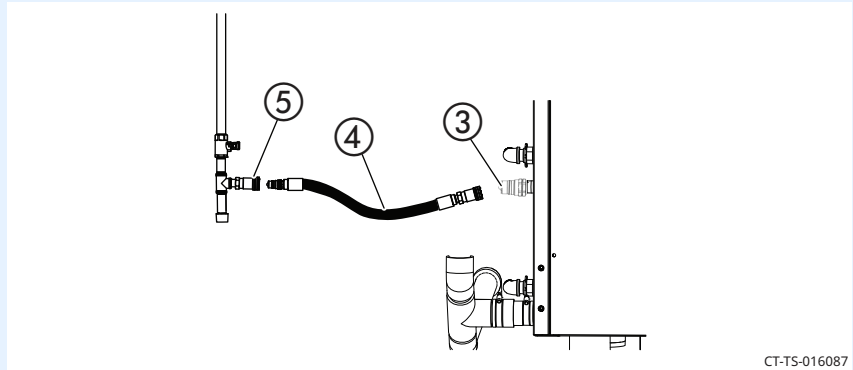

- | | |
|----|--|
| 3. | <p>Install the flexible connector ④ to the gas supply ⑤ using the quick disconnect.</p> |
|----|--|

Result

The gas connections are now installed.

How to Install the Water Supply

Before you begin



NOTE: Refer to the detailed instructions that come with the installation kit.

NOTICE

Significant damage to the appliance cavity, elements, or heat exchanger could result from improper water quality. Failure to meet the water quality requirements will void the warranty.

Make sure:

- The supply lines are flexible to allow the oven to be moved when service or cleaning is needed.
- For units under IEC/EN jurisdiction: This appliance is intended to be permanently connected to the water mains. Comply with local codes when installing this appliance.
- The incoming water supply is shut off when the oven is not being used.

Requirements

Water requirements:

- Two (2) water inlets, drinking quality
 - One treated water inlet: 3/4" NPT connection. Line pressure 30 psi minimum dynamic and 90 psi maximum static (200–600 kPa) at a minimum flow rate of 0.26 gpm (1 L/min). Install a back-flow preventer where required by local code.
 - One untreated water inlet: 3/4" NPT connection. Line pressure 30 psi minimum dynamic and 90 psi maximum static (200–1000 kPa) at a minimum flow rate of 2.64 gpm (10 L/min). Install a back-flow preventer where required by local code.
- Water temperature range: 50°–140°F (10°–60°C).
- Water drain: 1-1/2" (40mm) connection with a vertical vent to extend above the exhaust vent. Materials must withstand temperatures up to 200°F (93°C).
- Drain must not be located directly underneath the appliance unless a stand with a solid top or shelf is used to prevent steam from entering the oven.

Continued on next page

Continued from previous page

Water quality standards

It is the sole responsibility of the owner/operator/purchaser of this equipment to verify that the incoming water supply is comprehensively tested and, if required, a means of “water treatment” provided that would meet compliance requirements with the published water quality standards shown below. Non-compliance with these minimum standards will potentially damage this equipment and/or components and void the original equipment manufacturer’s warranty. Alto-Shaam recommends using the Alto-Shaam Reverse Osmosis System to properly treat your water.

Contaminant	Treated Water	Untreated Water
Free Chlorine	less than 0.1 ppm (mg/L)	less than 0.1 ppm (mg/L)
Hardness	30-70 ppm	30-70 ppm
Chloride	less than 30 ppm (mg/L)	less than 30 ppm (mg/L)
pH	7.0-8.5	7.0-8.5
Silica	less than 12 ppm (mg/L)	less than 12 ppm (mg/L)
Total Dissolved Solids (TDS)	50-125 ppm	50-360 ppm

Installing the water supply

To install the water supply, do the following.

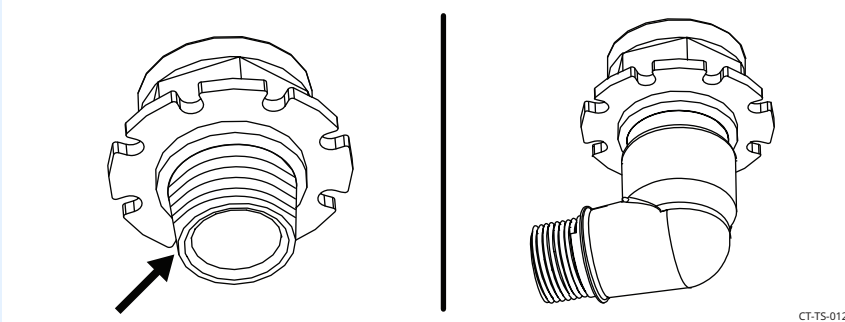
Step	Action
1.	Flush the water line at the installation site.
2.	Install adequate back-flow protection to comply with applicable federal, state, and local codes.
3.	<p>Apply thread sealant to the threads of the adapter fittings.</p> <p>Install the elbow from the kit onto the adapter fitting.</p> 

Continued on next page

Continued from previous page

4. **Install** the water hoses onto the elbows.

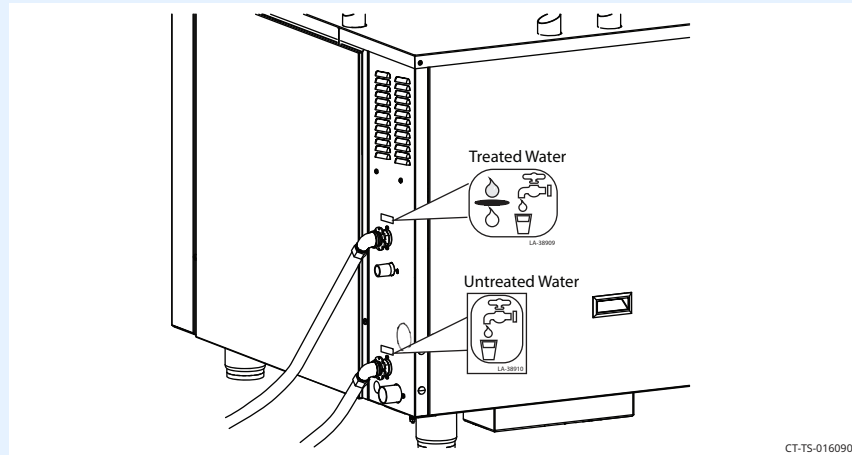

Result

The water supply is now installed.

How to Install the Water Drain

Before you begin



NOTE: Refer to the detailed instructions that come with the installation kit.

NOTICE

Significant damage to the appliance cavity, elements, or heat exchanger could result from improper water quality. Failure to meet the water quality requirements will void the warranty.

Make sure:

- The supply lines are flexible to allow the oven to be moved when service or cleaning is needed.
- For units under IEC/EN jurisdiction: This appliance is intended to be permanently connected to the water mains. Comply with local codes when installing this appliance.
- The incoming water supply is shut off when the oven is not being used.

Requirements

Water requirements:

- Two (2) water inlets, drinking quality
 - One treated water inlet: 3/4" NPT connection. Line pressure 30 psi minimum dynamic and 90 psi maximum static (200–600 kPa) at a minimum flow rate of 0.26 gpm (1 L/min). Install a back-flow preventer where required by local code.
 - One untreated water inlet: 3/4" NPT connection. Line pressure 30 psi minimum dynamic and 90 psi maximum static (200–1000 kPa) at a minimum flow rate of 2.64 gpm (10 L/min). Install a back-flow preventer where required by local code.
- Water temperature range: 50°–140°F (10°–60°C).
- Water drain: 1-1/2" (40mm) connection with a vertical vent to extend above the exhaust vent. Materials must withstand temperatures up to 200°F (93°C).
- Drain must not be located directly underneath the appliance unless a stand with a solid top or shelf is used to prevent steam from entering the oven.

Continued on next page

Continued from previous page

Water quality standards

It is the sole responsibility of the owner/operator/purchaser of this equipment to verify that the incoming water supply is comprehensively tested and, if required, a means of “water treatment” provided that would meet compliance requirements with the published water quality standards shown below. Non-compliance with these minimum standards will potentially damage this equipment and/or components and void the original equipment manufacturer’s warranty. Alto-Shaam recommends using the Alto-Shaam Reverse Osmosis System to properly treat your water.

Contaminant	Treated Water	Untreated Water
Free Chlorine	less than 0.1 ppm (mg/L)	less than 0.1 ppm (mg/L)
Hardness	30-70 ppm	30-70 ppm
Chloride	less than 30 ppm (mg/L)	less than 30 ppm (mg/L)
pH	7.0-8.5	7.0-8.5
Silica	less than 12 ppm (mg/L)	less than 12 ppm (mg/L)
Total Dissolved Solids (TDS)	50-125 ppm	50-360 ppm

Installing the support bracket

Step Action

1. **Remove** the screw in the back left corner at the top of the oven. Clean the area ① with a mixture of isopropyl alcohol and water. Place the double-sided tape from the kit onto the oven.

Place the support bracket onto the oven. Install the screw securing the bracket to the oven. An extra hole is provided in the bracket for a self-tapping screw if required to secure the bracket.

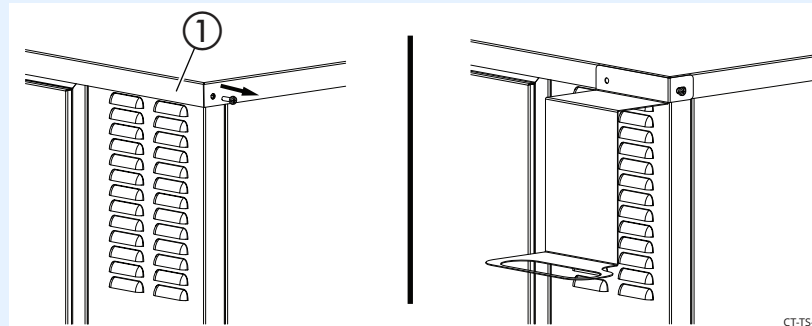

CT-TS-016105

Continued on next page

Continued from previous page

Water drain for single oven

The drain line must always be a descending gradient away from the oven. An end of drain run air gap may be required by local code. Vertical air required.

NOTICE

In the U.S.A., this equipment must be installed to comply with the Basic Plumbing Code of the Building Officials and Code Administrators International, Inc. (BOCA), and the Food Service Sanitation Manual of the Food & Drug Administration (FDA).

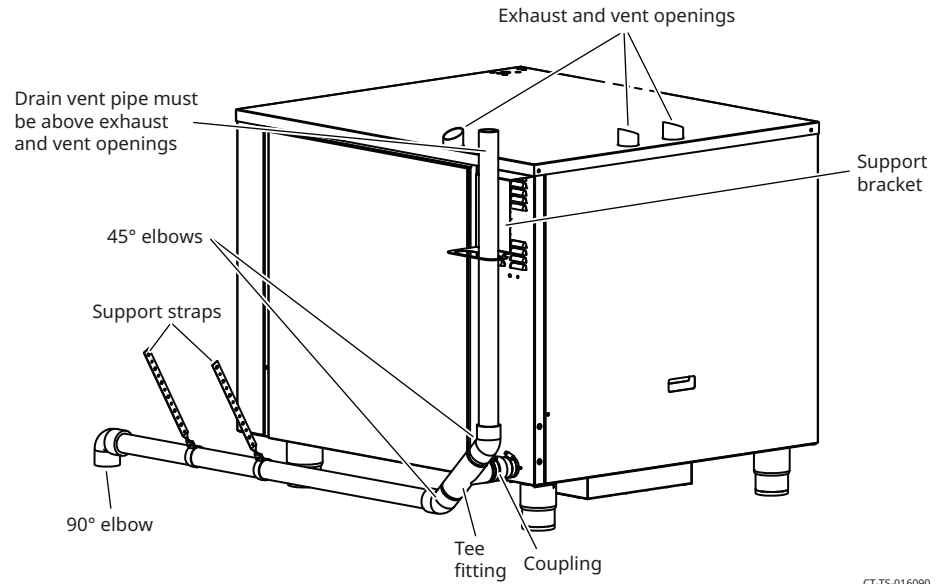

Continued on next page

Continued from previous page

Water drain for stacked ovens

Install the support bracket to the upper oven. Install the drain and vent piping as shown. The drain line must always be a descending gradient away from the oven. An end of drain run air gap may be required by local code. Vertical air required.

NOTICE

In the U.S.A., this equipment must be installed to comply with the Basic Plumbing Code of the Building Officials and Code Administrators International, Inc. (BOCA), and the Food Service Sanitation Manual of the Food & Drug Administration (FDA).

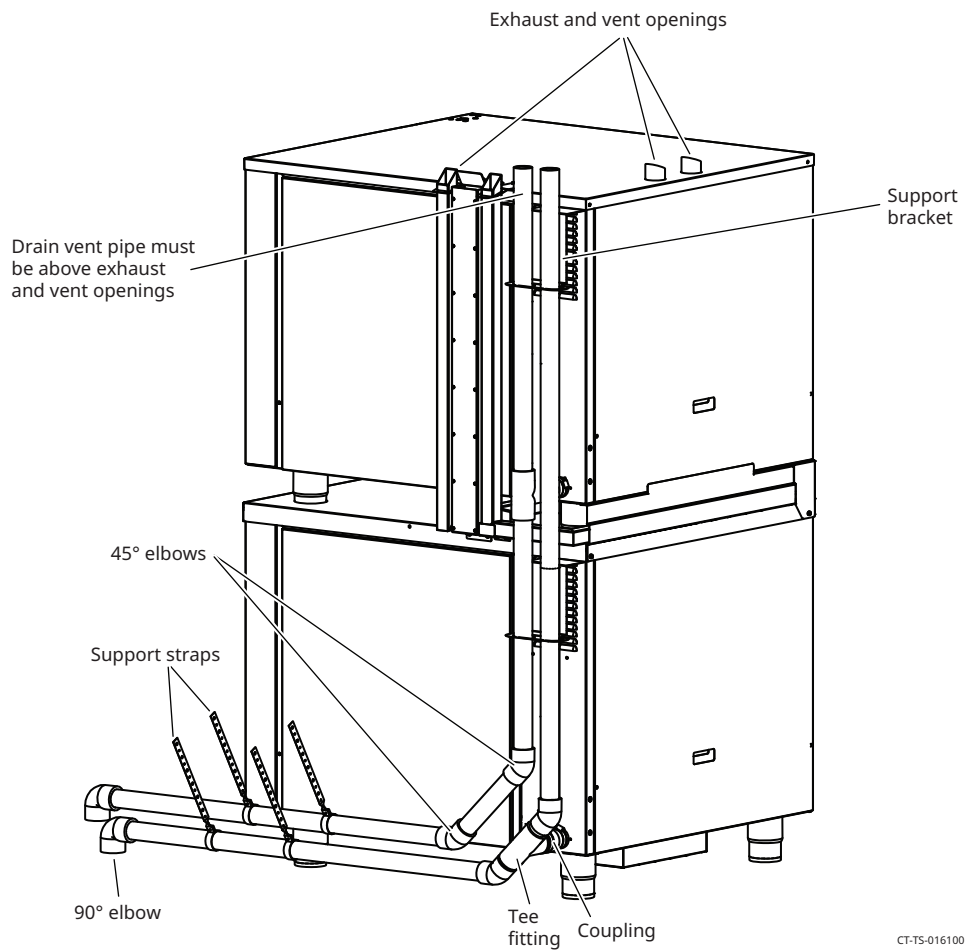

Continued on next page

Continued from previous page

Installing drain and vent piping

2. **Install** the coupling onto the oven drain.

Cut a short piece (3.25" minimum) of drain pipe. **Install** the drain pipe into the Tee fitting from the kit. **Install** the drain pipe and Tee fitting into the coupling.

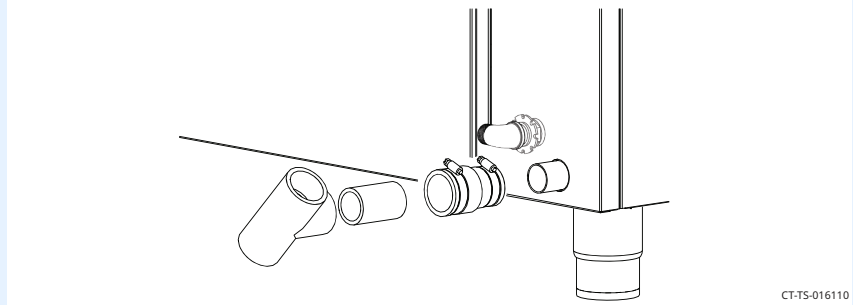

3. **Cut** a short piece (3.25" minimum) of drain pipe and install a 45° elbow into the Tee fitting. Install the vent pipe into the elbow fitting.

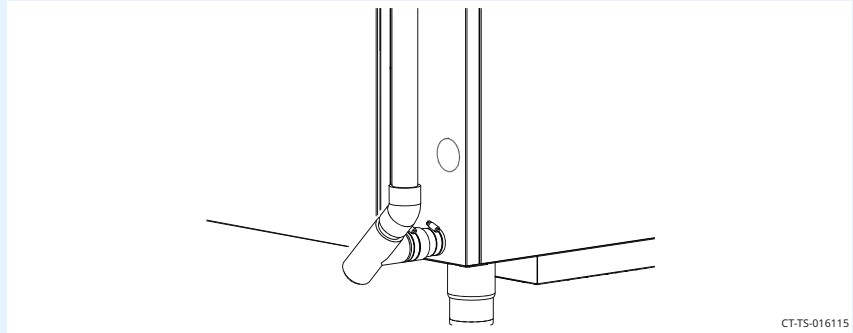

4. **Install** the 45° elbow to the Tee. **Install** the drain pipe. **Install** the 90° elbow. **Secure** the drain pipe with the clamps and straps in the kit.

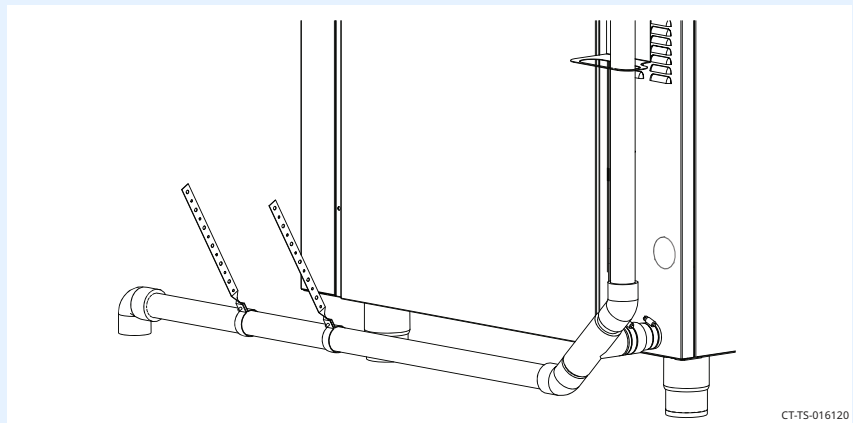

Result

The water drain is now installed.

How to Install the Liquid Cleaner (if equipped)

Before you begin



WARNING: Burn hazard.

Wear protective gloves, protective clothing, eye protection, and face protection when handling oven cleaner.

Procedure

To install the liquid cleaner, do the following.

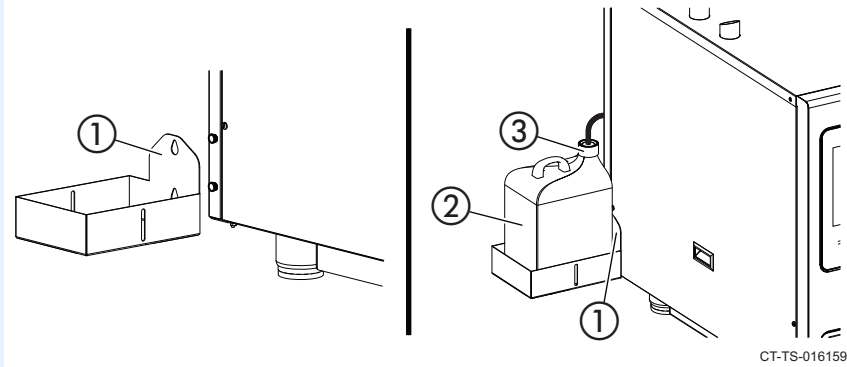
Step	Action
1.	<p>Mount the cleaner support tray ① on the left or right exterior panel of the oven. Slide the slotted openings on the cleaner support tray over the mounting studs.</p>  <p>The cleaner support tray holds a 2-1/2-gallon (9.5 liter) bottle.</p>
2.	<p>Place the liquid cleaner bottle ② inside the support tray.</p>
3.	<p>Locate the cleaner cap and tubing assembly ③ on the rear of the oven and screw the cleaner cap onto the liquid cleaner bottle.</p>
4.	<p>Position the cleaner cap so that the tubing assembly is not kinked after the cleaner cap is tightened.</p> <p>The liquid cleaner is automatically pumped through the system during each liquid cleaning cycle.</p>

Result

The liquid cleaner is now installed.

How to Install the Grease Collection System (if equipped)

Before you begin

The grease collection valve requires 6" (152mm) of vertical clearance.
The handle of the grease collection valve must be parallel to the side of the oven.

Procedure

To install the grease collection system, do the following.

- | Step | Action |
|------|---|
| 1. | Unpack the grease collection valve assembly and the grease collection container assembly. |
| 2. | Install the hose guide bracket ① using the thumb screws.
Install the grease collection hose ② through the guide. |

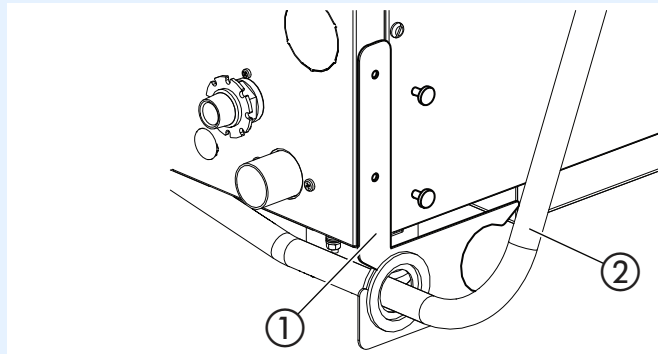

CT-TS-016162

- | | |
|----|--|
| 3. | Install the hose hanger bracket ③.
Make sure the valve ④ is in the closed position. |
|----|--|

i **NOTE:** For stacked configurations, make sure to install the hose hanger bracket on the bottom of the top oven.

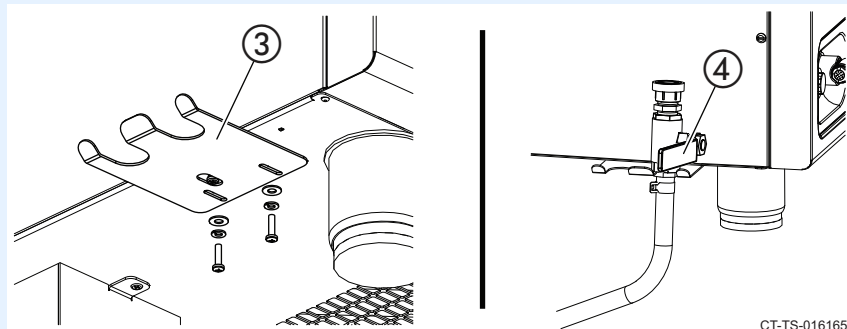

CT-TS-016165

Continued on next page

Continued from previous page

4. **Loosen** the radial nut ⑤ on the grease collection container union. **Insert** the grease collection hose into the union fitting and turn until tight. **Make sure** the valve ④ is in the open position.

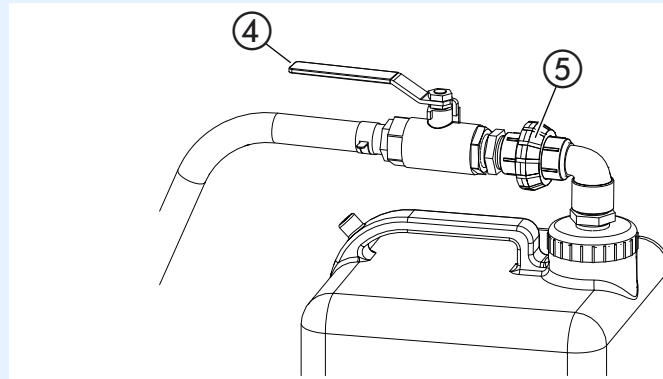

CT-TS-016168

5. **Tighten** the radial nut on the grease collection container.
6. **Place** the grease collection container inside the tray of the mobile grease collection cart ⑥. Roll it into place next to the oven and apply the caster brake.

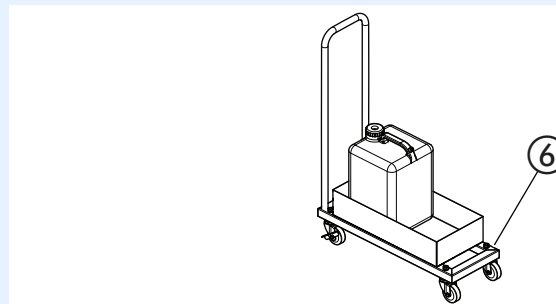

AR-TS-005596

Result

The grease collection system is now installed.

This page is intentionally left blank.

How to Turn On and Turn Off the Oven

Before you begin

- The oven must be connected to electric power.
- Make sure the gas supply is connected.
- Make sure the water supply is connected.

Turning on the oven

To turn on the oven, do the following.

Step	Action
1.	Touch the ON/OFF button ①.

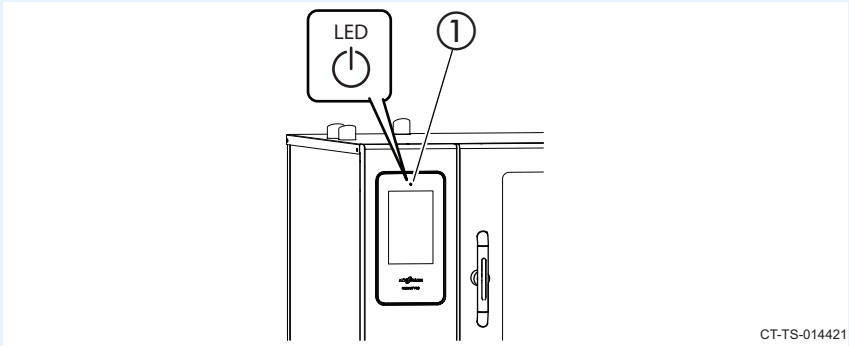

CT-TS-014421

The oven is now on.

Turning off the oven

To turn off the oven, do the following.

2. **Touch** and hold the ON/OFF button ① until the "Shut Down Options" screen displays. **Touch** "Shut down" ②.

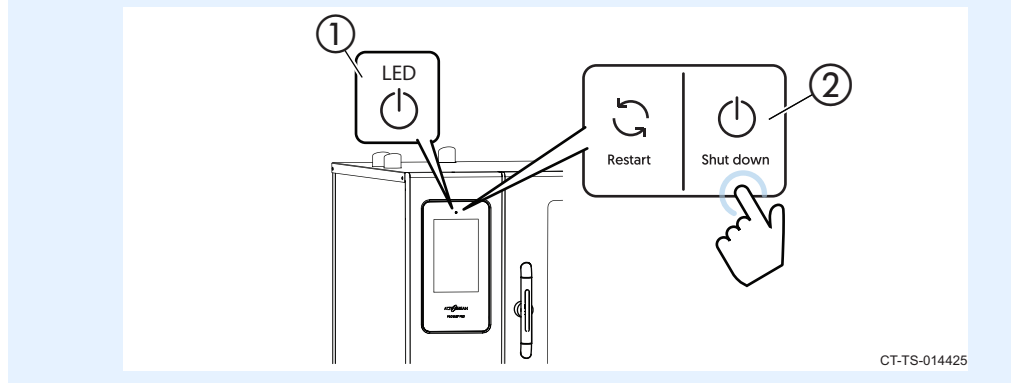

The oven is now off.

Post-Installation Checklist

Download and complete the [Post-Installation Checklist](#) and send it to Alto-Shaam Service. Click the link or scan the QR Code for the checklist.



The graphic below is for reference only.



Post-Installation Checklist

• Complete a copy of this form for each oven in the kitchen, or when there are significant differences between the oven installation locations within a kitchen.
 • See the Installation Manual, Operator's Manual and Specification Sheets for installation procedures.
 • Boxes outlined in red are required fields. If there is no applicable answer for the associated question, type: "n/a" in the box.

Post-Installation Checklist

Location Information	
Location Name: _____	Site Contact Name: _____
Location Street Address: _____	Site Contact Phone No.: _____
Location City: _____	Site Contact Email: _____
Location State: _____ Zip Code: _____	
Post-Installation Company Information	
Company Name: _____	Service Technician Name: _____
Mailing Address: _____	Service Technician Phone No.: _____
City: _____	Contact Email: _____
State: _____ Zip Code: _____	Date of Installation: _____
Model number(s) of Combis installed: _____	
Serial number(s) of Combis installed: _____	
Clearance	
Minimum Appliance clearance Right side	PASS <input type="radio"/> FAIL <input type="radio"/>
(Refer to clearances noted on the respective Specification Sheet) Left side	PASS <input type="radio"/> FAIL <input type="radio"/>
Rear	PASS <input type="radio"/> FAIL <input type="radio"/>
Top	PASS <input type="radio"/> FAIL <input type="radio"/>
Is the appliance accessible for service? YES <input type="radio"/> NO <input type="radio"/>	
If NO, comment on the issue: _____	
Other comments: _____	
Water Supply	
Have all treated water inlets been connected to the water supply?	PASS <input type="radio"/> FAIL <input type="radio"/>
Have all untreated water inlets been connected to the water supply?	PASS <input type="radio"/> FAIL <input type="radio"/>
Do the water supply line(s) have shut-off(s) exclusively for each appliance?	PASS <input type="radio"/> FAIL <input type="radio"/>
Is the dynamic water pressure from the cold water supply line a minimum of 30 psi (200 kPa) for each appliance?	PASS <input type="radio"/> FAIL <input type="radio"/> UNKNOWN <input type="radio"/>
Is the static water pressure from the cold water supply line less than 90 psi (600 kPa) for each appliance?	PASS <input type="radio"/> FAIL <input type="radio"/> UNKNOWN <input type="radio"/>
Is the minimum water flow rate correct for the treated water line? 0.16 gpm (0.6 L/min) for Converge models, 0.26 gpm (1 L/min) for 6-10, 10-10 and 7-20 models, 0.53 gpm (2 L/min) for 10-20 models, and 0.80 gpm (3 L/min) for 20-10 and 20-20 models	PASS <input type="radio"/> FAIL <input type="radio"/> UNKNOWN <input type="radio"/>
Is the minimum water flow rate for the untreated water line 2.6 gpm (10 L/min) for Prodigy or 4.0 gpm (15 L/min) for Converge?	PASS <input type="radio"/> FAIL <input type="radio"/> UNKNOWN <input type="radio"/>
Is water treatment (RO blend system, filter, etc.) being used?	YES <input type="radio"/> NO <input type="radio"/> TYPE _____
If YES - Note the system here: _____ BRAND NAME _____ MODEL _____	
Are all exterior water connections tight?	YES <input type="radio"/> NO <input type="radio"/>
Are all interior water connections tight before operation?	YES <input type="radio"/> NO <input type="radio"/>
Are there any exterior water leaks after operation?	YES <input type="radio"/> NO <input type="radio"/>
Are there any interior water leaks after operation?	YES <input type="radio"/> NO <input type="radio"/>
Comments: _____	

Error Codes

Code	Component	Description	Troubleshooting steps
E-5	2 - Convection fan	Convection fan (upper) under speed	<ol style="list-style-type: none"> 1. Power down control using on/off icon. 2. Cycle power to the oven either by unplugging the unit or by turning the main power switch off and then back on. 3. Resume use of oven. If error reappears contact a service provider.
E-5	2 - Convection fan	Lower convection fan under speed	<ol style="list-style-type: none"> 1. Power down control using on/off icon. 2. Cycle power to the oven either by unplugging the unit or by turning the main power switch off and then back on. 3. Resume use of oven. If error reappears contact a service provider.
E-10	44 - Cavity sensor	Cavity sensor short	<ol style="list-style-type: none"> 1. Power down control using on/off icon. 2. Cycle power to the oven either by unplugging the unit or by turning the main power switch off and then back on. 3. Resume use of oven. If error reappears contact a service provider.
E-10	47 - Food probe	Food probe short	<ol style="list-style-type: none"> 1. Investigate food probe for damage. Replace if damaged. 2. Power down control using on/off icon. 3. Cycle power to the oven either by unplugging the unit or by turning the main power switch off and then back on. 4. Resume use of oven. If error reappears contact a service provider.
E-10	52 - Steam injector	Steam injector sensor short	<ol style="list-style-type: none"> 1. Power down control using on/off icon. 2. Cycle power to the oven either by unplugging the unit or by turning the main power switch off and then back on. 3. Resume use of oven. If error reappears contact a service provider.
E-10	55 - Tank	Tank sensor short	<ol style="list-style-type: none"> 1. Power down control using on/off icon. 2. Cycle power to the oven either by unplugging the unit or by turning the main power switch off and then back on. 3. Resume use of oven. If error reappears contact a service provider.
E-11	44 - Cavity sensor	Cavity sensor open	<ol style="list-style-type: none"> 1. Power down control using on/off icon. 2. Cycle power to the oven either by unplugging the unit or by turning the main power switch off and then back on. 3. Resume use of oven. If error reappears contact a service provider.

Code	Component	Description	Troubleshooting steps
E-11	52 - Steam injector	Stem injector sensor open	<ol style="list-style-type: none"> 1. Power down control using on/off icon. 2. Cycle power to the oven either by unplugging the unit or by turning the main power switch off and then back on. 3. Resume use of oven. If error reappears contact a service provider.
E-11	55 - Tank	Tank sensor open	<ol style="list-style-type: none"> 1. Power down control using on/off icon. 2. Cycle power to the oven either by unplugging the unit or by turning the main power switch off and then back on. 3. Resume use of oven. If error reappears contact a service provider.
E-31	2 - Convection fan (Classic control)	Motor (upper) over temperature	<ol style="list-style-type: none"> 1. Power down control using on/off icon. 2. Cycle power to the oven either by unplugging the unit or by turning the main power switch off and then back on. 3. Resume use of oven. If error reappears contact a service provider.
E-31	2 - Convection fan (Classic control)	Lower motor over temperature	<ol style="list-style-type: none"> 1. Power down control using on/off icon. 2. Cycle power to the oven either by unplugging the unit or by turning the main power switch off and then back on. 3. Resume use of oven. If error reappears contact a service provider.
E-31	2 - Convection fan	Motor VFD (upper) over temperature	<ol style="list-style-type: none"> 1. Make sure cooling fan(s) are operating. 2. Make sure exhaust vents are clean and free of debris. 3. Make sure oven clearances are met. 4. Ambient temperature greater than 105°F (41°C).
E-31	2 - Convection fan	Lower motor VFD over temperature	<ol style="list-style-type: none"> 1. Make sure cooling fan(s) are operating. 2. Make sure exhaust vents are clean and free of debris. 3. Make sure oven clearances are met. 4. Ambient temperature greater than 105°F (41°C).
E-31	44 - Cavity sensor	Chamber over temperature	<ol style="list-style-type: none"> 1. If the oven has experienced an over temperature condition allow the oven to cool down for a minimum of 30 minutes. 2. Press the high limit reset button. 3. Resume cooking operation. If error reappears contact service provider.
E-31	55 - Tank	Tank sensor over temperature	<ol style="list-style-type: none"> 1. If the oven has experienced an over temperature condition allow the oven to cool down for a minimum of 30 minutes. 2. Press the high limit reset button. 3. Resume cooking operation. If error reappears contact service provider.

Code	Component	Description	Troubleshooting steps
E-31	8 - Control Board	Control board too warm	<ol style="list-style-type: none"> 1. Make sure cooling fan(s) are operating. 2. Make sure exhaust vents are clean and free of debris. 3. Make sure oven clearances are met. 4. Ambient temperature greater than 105°F (41°C). 5. Check the door gasket for damage and proper seal.
E-31	9 - Interface Board	Interface board too warm	<ol style="list-style-type: none"> 1. Make sure cooling fan(s) are operating. 2. Make sure exhaust vents are clean and free of debris. 3. Make sure oven clearances are met. 4. Ambient temperature greater than 105°F (41°C). 5. Check the door gasket for damage and proper seal.
E-55	56 - Vent valve	Vent (upper) not open	<ol style="list-style-type: none"> 1. Power down control using on/off icon. 2. Cycle power to the oven either by unplugging the unit or by turning the main power switch off and then back on. 3. Resume use of oven. If error reappears contact a service provider.
E-55	56 - Vent valve	Lower vent valve not open	<ol style="list-style-type: none"> 1. Power down control using on/off icon. 2. Cycle power to the oven either by unplugging the unit or by turning the main power switch off and then back on. 3. Resume use of oven. If error reappears contact a service provider.
E-62	2 - Convection fan	Motor VFD (upper) over current	<ol style="list-style-type: none"> 1. Power down control using on/off icon. 2. Cycle power to the oven either by unplugging the unit or by turning the main power switch off and then back on. 3. Resume use of oven. If error reappears contact a service provider.
E-62	2 - Convection fan	Lower motor VFD over current	<ol style="list-style-type: none"> 1. Power down control using on/off icon. 2. Cycle power to the oven either by unplugging the unit or by turning the main power switch off and then back on. 3. Resume use of oven. If error reappears contact a service provider.
E-66	2 - Convection fan	VFD (upper) error	<ol style="list-style-type: none"> 1. Power down control using on/off icon. 2. Cycle power to the oven either by unplugging the unit or by turning the main power switch off and then back on. 3. Resume use of oven. If error reappears contact a service provider.
E-66	2 - Convection fan	Lower VFD error	<ol style="list-style-type: none"> 1. Power down control using on/off icon. 2. Cycle power to the oven either by unplugging the unit or by turning the main power switch off and then back on. 3. Resume use of oven. If error reappears contact a service provider.

Code	Component	Description	Troubleshooting steps
E-78	19 - Voltage sensor	Voltage monitor too low	<ol style="list-style-type: none"> 1. Check to make sure the unit plug is fully seated in the electrical outlet. 2. Reset the main circuit breaker for the oven. If error reappears contact service provider.
E-78	2 - Convection fan	VFD (upper) under voltage	<ol style="list-style-type: none"> 1. Check to make sure the unit plug is fully seated in the electrical outlet. 2. Reset the main circuit breaker for the oven. If error reappears contact service provider.
E-78	2 - Convection fan	Lower VFD under voltage	<ol style="list-style-type: none"> 1. Check to make sure the unit plug is fully seated in the electrical outlet. 2. Reset the main circuit breaker for the oven. If error reappears contact service provider.
E-79	19 - Voltage sensor	Voltage monitor too high	<ol style="list-style-type: none"> 1. Check to make sure the unit plug is fully seated in the electrical outlet. 2. Reset the main circuit breaker for the oven. If error reappears contact service provider.
E-79	2 - Convection fan	VFD (upper) over voltage	<ol style="list-style-type: none"> 1. Check to make sure the unit plug is fully seated in the electrical outlet. 2. Reset the main circuit breaker for the oven. If error reappears contact service provider.
E-79	2 - Convection fan	Lower VFD over voltage	<ol style="list-style-type: none"> 1. Check to make sure the unit plug is fully seated in the electrical outlet. 2. Reset the main circuit breaker for the oven. If error reappears contact service provider.
E-80	2 - Convection fan	VFD (upper) memory error	<ol style="list-style-type: none"> 1. Power down control using on/off icon. 2. Cycle power to the oven either by unplugging the unit or by turning the main power switch off and then back on. 3. Resume use of oven. If error reappears contact a service provider.
E-80	2 - Convection fan	Lower VFD memory error	<ol style="list-style-type: none"> 1. Power down control using on/off icon. 2. Cycle power to the oven either by unplugging the unit or by turning the main power switch off and then back on. 3. Resume use of oven. If error reappears contact a service provider.
E-88	1 - Heater	Gas ignition failure (upper)	<ol style="list-style-type: none"> 1. Power down control using on/off icon. 2. Cycle power to the oven either by unplugging the unit or turning off the breaker. 3. Inspect the top of oven for anything blocking the exhaust flue of the oven. 4. Make sure the ventilation hood is turned on and working properly. 5. Make sure the gas line is properly connected to the unit and the gas shut off valve is in the open position. 6. Resume cook operation. If error reappears turn the oven off, shut off the gas supply to the oven and immediately contact service provider.

Code	Component	Description	Troubleshooting steps
E-88	1 - Heater	Lower gas ignition failure	<ol style="list-style-type: none"> 1. Power down control using on/off icon. 2. Cycle power to the oven either by unplugging the unit or turning off the breaker. 3. Inspect the top of oven for anything blocking the exhaust flue of the oven. 4. Make sure the ventilation hood is turned on and working properly. 5. Make sure the gas line is properly connected to the unit and the gas shut off valve is in the open position. 6. Resume cook operation. If error reappears turn the oven off, shut off the gas supply to the oven and immediately contact service provider.
E-90	1 - Heater	Gas blower failure (upper)	<ol style="list-style-type: none"> 1. Power down control using on/off icon. 2. Cycle power to the oven either by unplugging the unit or by turning the main power switch off and then back on. 3. Resume use of oven. If error reappears contact a service provider.
E-90	1 - Heater	Lower gas blower failure	<ol style="list-style-type: none"> 1. Power down control using on/off icon. 2. Cycle power to the oven either by unplugging the unit or by turning the main power switch off and then back on. 3. Resume use of oven. If error reappears contact a service provider.
E-93	8 - Control Board	State synchronization error between the interface board and control board	<ol style="list-style-type: none"> 1. Clear error by pressing the check mark on the display to accept the error. 2. If the error persists contact Alto-Shaam Technical Support.
E-94	10 - Control Board Communications	Communication error between Interface Board and Control Board	<ol style="list-style-type: none"> 1. Power down control using on/off icon. 2. Cycle power to the oven either by unplugging the unit or by turning the main power switch off and then back on. 3. Resume use of oven. If error reappears contact a service provider.
E-94	2 - Convection fan	VFD (upper) communication error	<ol style="list-style-type: none"> 1. Power down control using on/off icon. 2. Cycle power to the oven either by unplugging the unit or by turning the main power switch off and then back on. 3. Resume use of oven. If error reappears contact a service provider.
E-94	2 - Convection fan	Lower VFD communication error	<ol style="list-style-type: none"> 1. Power down control using on/off icon. 2. Cycle power to the oven either by unplugging the unit or by turning the main power switch off and then back on. 3. Resume use of oven. If error reappears contact a service provider.
E-102	59 - Ventless hood	Ventless hood filter Fault	<ol style="list-style-type: none"> 1. Check if filters are installed. 2. Check if filters are clogged. 3. Check operation of hood fan.

Code	Component	Description	Troubleshooting steps
E-105	6 - Chamber	Low water pressure	<ol style="list-style-type: none"> 1. Water supply not connected. 2. Water supply is shut off. 3) Water supply to unit blocked or obstructed (check filter).
E-109	6 - Chamber	Chamber high limit	<ol style="list-style-type: none"> 1. If the oven has experienced an over temperature condition, allow the oven to cool down for a minimum of 30 minutes. 2. Press the high limit reset button. 3. Resume cooking operation. If error reappears contact service provider.
E-606	6 - Chamber	Error during cleaning cycle	<ol style="list-style-type: none"> 1. Manually Clean Oven. 2. Manually Rinse Oven. 3. Ensure chemicals removed before use. 4. Resume use of oven. If error repeats contact service provider.
E-999	48 - Personality handler	IB and CB dip switch settings not set correctly	<ol style="list-style-type: none"> 1. Power down control using on/off icon. 2. Cycle power to the oven either by unplugging the unit or by turning the main power switch off and then back on. 3. Resume use of oven. If error reappears contact a service provider.



ALTO-SHAAM.

Menomonee Falls, WI U.S.A.

Phone 800-558-8744 | +1-262-251-3800 | alto-shaam.com

ASIA

Shanghai, China
Phone +86-21-6173-0336

AUSTRALIA

Brisbane, Queensland
Phone 800-558-8744

CANADA

Concord, Ontario Canada
Toll Free Phone 866-577-4484
Phone +1-905-660-6781

FRANCE

Aix en Provence, France
Phone +33(0)4-88-78-21-73

GMBH

Bochum, Germany
Phone +49 (0)234 298798-0

ITALY

Padua, Italy
Phone +39 3476073504

INDIA

Pune, India
Phone +91 9657516999

MEXICO

Phone +52 1 477-717-3108

MIDDLE EAST & AFRICA

Dubai, UAE
Phone +971-4-321-9712

CENTRAL & SOUTH AMERICA

Miami, FL USA
Phone +1 954-655-5727

RUSSIA

Moscow, Russia
Phone +7 903 7932331