

DOYON & NU-VU
5600 13th Street
Menominee, MI, USA
49858

Tel.: 1 (906) 863-4401

Canada & US:

1 (800) 338-9886

FAX: 1 (906) 863-5889

Internet: <http://www.doyon.qc.ca>

e-mail: doyon@doyon.qc.ca

AFR150

Serial number / Numéro de série: _____

INDEX

LANGUAGE EN	3
CHAPTER 1	3
NAMEPLATE AND INDUSTRIAL USE	3
1.1 - MACHINE NAMEPLATE	3
1.2 - INSTRUCTIONS MANUAL	3
1.3 - GENERAL DESCRIPTION	3
1.4 - INDUSTRIAL USE OF THE MACHINE	3
CHAPTER 2	3
TRANSPORTATION, STORAGE, MOUNTING, INSTALLATION AND CONNECTING	4
2.1 - TRANSPORTATION	4
2.2 - STORAGE	4
2.3 - ASSEMBLING AND INSTALLATION	4
2.4 - CONNECTING AND ELECTRICAL SUPPLY	4
CHAPTER 3	5
MACHINE USAGE	5
3.1 - MACHINE CONTROL PANEL	5
3.1.1 – Analog control	5
3.1.2 – Conventional digital control	5
3.1.3 – Touch-screen digital touch-screen	5
3.1.4 – Emergency stop	5
3.1.5 - Ingredient feeding	5
3.2 - FUNCTIONING – ANALOG CONTROL	5
3.2.1 - Rotation check	5
3.2.2 – Working in manual mode	6
3.2.2.1- Starting the machine	6
3.2.2.2 – Select and screen speeds “1” and “2”	6
3.2.2.3 – Change speed	6
3.2.2.4 – Stopping the machine	6
3.2.2.5 – Rotation to unload the dough	6
3.2.3 - Working in automatic mode	6
3.2.3.1 – Running a programme	6
3.2.3.2 – Stopping the machine	6
3.2.3.3 – Rotation to unload dough	6
3.3 - FUNCTIONING – CONVENTIONAL DIGITAL CONTROL	6
3.3.1 - Rotation check	7
3.3.2 – Choosing work mode	7
3.3.3 - Working in standby mode	7
3.3.4 - Working in manual mode	7
3.3.4.1 – Starting the machine	7
3.3.4.2 – Selecting and seeing speed “1” and “2”	7
3.3.4.3 – Changing speed	7
3.3.4.4 – Screening elapsed time	8
3.3.4.5 – Bowl reversal at speed “1” (optional function)	8
3.3.4.6 – Bowl reversal during discharge – (optional function)	8
3.3.4.7 – Adding water – (optional function)	8
3.3.4.8 – Stopping the machine	8
3.3.5 - Working in automatic mode	8
3.3.5.1 – Starting the machine	8
3.3.5.2 – Programme editing	8
3.3.5.3 – Programme saving	9
3.3.5.4 – Programme running	9
3.3.5.5 – Seeing work time	9
3.3.5.6 – Bowl reversal at speed “1” (optional function)	9
3.3.5.7 – Bowl reversal during discharge – (optional function)	9
3.3.5.8 – Adding water – (optional function)	9
3.3.5.9 – Stopping the machine	10
3.3.5.10 – Messages	10
3.4 - FUNCTIONING – TOUCH-SCREEN DIGITAL CONTROL	10
3.4.1 - Rotation direction check	10
3.4.2 – Choosing work mode	10
3.4.3 - Working in manual mode	11
3.4.3.1 – Adding water – optional function	12
3.4.3.2 – Bowl reversal – optional function	12
3.4.4 - Working in automatic mode	12
3.4.4.1 – Selecting a programme	12
3.4.4.2 - Altering or installing programmes	13
3.4.4.3 – Bowl reversal - optional function	14
3.4.5 – Language selection screen	14
3.4.6 – Equipment usage screen	14
3.4.7 – Other products disclosure screen	14
3.4.8 – Entries and exits state and counter screen	14
3.4.9 – Messages	15
3.5 - FAILURE DETECTION AND SOLVING	15
3.6 - PROTECTION MEASURES	16
3.7 - ACCESSORIES AND TOOLS	16
3.8 - MACHINE STABILITY	16
CHAPTER 4	16
PROPERTIES OF THE MACHINE	16
4.1 - MECHANICAL PROPERTIES	16
4.2 - ELECTRICAL PROPERTIES	16

4.3 - MACHINE CAPACITY	16
4.4 - SECURITY SYSTEM	16
4.5 - PRECAUTION WITH TOOLS.....	16
4.6 - PRECAUTION WITH BELTS	16
4.7 - NOISE EMISSION.....	16
4.8 - RADIATION EMISSION.....	17
4.9 - LIFE CYCLE OF TEH PRODUCT	17
CHAPTER 5.....	17
MAINTENANCE	17
5.1 - WHEN THE MACHINE IS NEW	17
5.2 - EVERYDAY	17
5.2.1 - Machine cleaning.....	17
5.2.2 - SECURITY SYSTEM CHECK	18
5.3 - EVERY SIX MONTHS	18
5.3.1 - Belts check	18
5.3.2 - Bowl rollers check	20
5.3.3 - General tuning and lubrication check	21
5.3.4 - Machine fixation check	21

LANGUAGE EN
CHAPTER 1
NAMEPLATE AND INDUSTRIAL USE

1.1 - MACHINE NAMEPLATE

This machine has a nameplate describing properties, fixed on the outer part on which the general properties are described:

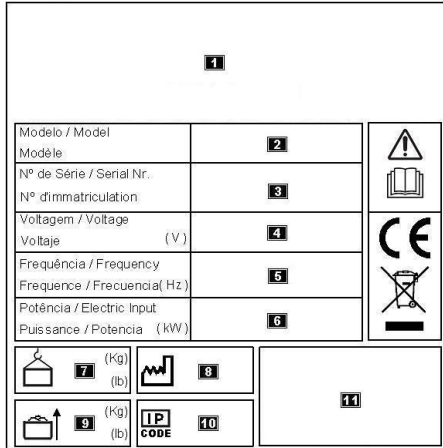

Image Caption:

Area	Purpose
1	Identification of the manufacturer including full address
2	Model
3	Serial Number
4	Voltage
5	Frequency
6	Power
7	Weight of the machine
8	Year and month of fabrication
9	Maximum load lifting (if applicable)
10	IP protection degree (unmarked for IPx0)
11	Fabrication country

1.2 - INSTRUCTIONS MANUAL

	<p>Fully respect the content of this instructions manual.</p> <p>This instructions manual is part of the machine and must be kept at reach of the user throughout the useful life of the machine, under conditions that preserve its integrity and durability.</p>
--	--

1.3 - GENERAL DESCRIPTION

Thank you for choosing or using this equipment. It is our goal to provide reliable, safe and functional equipments, qualitatively adequate to the most demanding mechanical, electrical, ergonomic and food norms. Furthermore, several (electrical, mechanical, among other) tests are developed so as to assure the final quality of the supplied equipments.

Technically, this equipment may be defined as follows: Equipment composed of a steel structure, a series of mechanical devices that, when electrically triggered, transform food dough. Based on its manufacturing and operating technological level, this transformation of products happens without the need for human intervention. Thus, it is easier to obtain a uniform final product – considering the defined parameters and corresponding specifications.

1.4 - INDUSTRIAL USE OF THE MACHINE

	<p>CAUTION</p> <p>Non-qualified users are forbidden to operate the machine.</p> <p>Inappropriate operation of the machine is forbidden.</p>
--	--

This machine has been designed to be operated in the production of bakery and pastry dough.
 This machine has been designed to be operated by only one, duly qualified, user and its job is next illustrated.

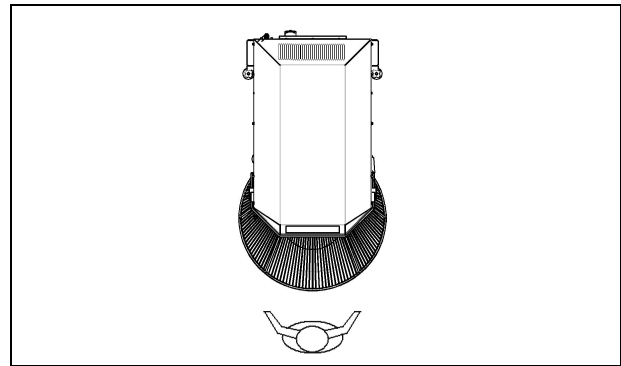

The intervention of the machine operator consists of the following:
 Placing ingredients;
 Discharging mixed dough from the bowl;
 Closing and opening the protection grid;
 Activating the control panel of the machine.

The qualification level for a job may be achieved either through specific training on this machine and production processes, or through duly proved know-how experience. The qualification of the operator must be proved when requested.

Throughout the entire manual the operation of the machine is regarded on an 8 hour daily schedule, notwithstanding the machine not working for uninterrupted 8 hours. When the machine is used in a different period, considerations must be adjusted to the proportion of that use.

The manufacturer may not be held responsible for any damage to the machine, people, property or animals, resulting from an inappropriate use.

It is to be considered an inappropriate use of the machine:

- Using the machine under inadequate environmental, operational and physical conditions;
- Using the machine disregarding the good practice of the art of bakery and pastry;
- The use of the machine by a non-qualified operator;
- Mixing products for which it has not been designed;
- Using ice during kneading;
- Kneading dough with insufficient hydration;
- Operating the machine without its complete installation;
- Powering energy different to that specified;
- Altering performances;
- Removing or changing security systems;
- Disrespecting the current laws in the country or the contents of this manual.

**CHAPTER 2
TRANSPORTATION, STORAGE, MOUNTING, INSTALLATION
AND CONNECTING**

The incorrect transportation, storage, mounting, installation or connection of this machine by the client or representative may cause material, people, property or animal damage, the manufacturer not being held responsible for this.

2.1 - TRANSPORTATION

Always use an adequate transportation device regarding the weight on the nameplate.

Always act in compliance with the current laws in your country. The ignorance of such laws does not justify incomppliance.

The machine must be transported according to the following images, with a freight elevator, adequate cables, ropes, chains or hooks.

In case of manual handling the risk of the machine over-sliding or sliding in an unexpected direction, must be taken into account.

Regularly check the package for damage subsequent to transportation. In case of damage suspicion, please contact the supplier for examination or record the event so as to later describe the situation.

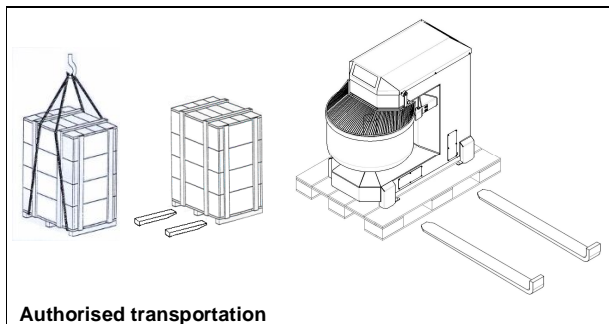

Authorized transportation

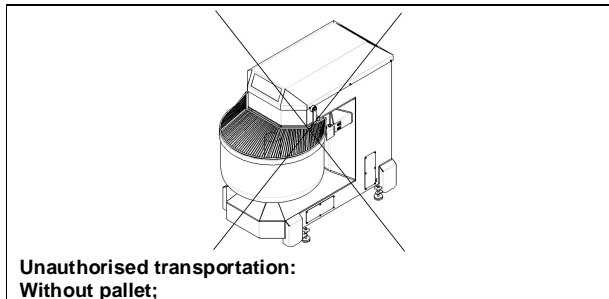

**Unauthorised transportation:
Without pallet;**

2.2 - STORAGE

Always use transportation equipment for storage that is adequate to the weight on the nameplate of this machine. The storage site has to hold the same weight, thus ground storage is recommendable, avoiding shelves or elevated storage reduces the risk of machine fall. There is no need for it to be fixed to the ground, however, the pavement must be flat and must not be slippery. The pavement should be free of humidity so as to avoid oxidation on painted chassis machines.

During storage, it is mandatory that the machine is disconnected from electrical power supply, but under not circumstances should it be stored subject to bad weather conditions, it must be kept in conditions similar to the work place.

2.3 - ASSEMBLING AND INSTALLATION

	<p>During assembling and installation at the work place, make sure the power supply cable is disconnected from the socket. This should be performed by duly accredited personnel by the manufacturer.</p>
--	--

By the operating place of the machine, remove all packaging, such as cardboard, plastic, pallets, protection wood, film and others.

At the exact work place, the machine must be levelled by mounting the anti-vibration pads as in the following picture.

All the supports of this machine must be adjusted to the floor.

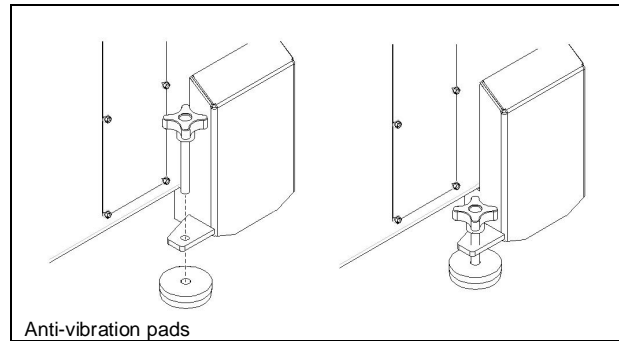

Anti-vibration pads

	<p>Never run the machine without its complete installation.</p>
--	--

The pavement must be made of concrete, able to endure the weight of the machine and the load for which it is set, in compliance with the properties on the nameplate of the machine. The pavement must be of a single flat ballast, not containing amendments between the supports of the machine and having a maximum inclination of 0,5%. Anti-vibratory supports must be readjusted, whenever necessary.

Make sure no sand or other residue remain between the supports of the machine and the pavement so as to avoid false grips, oscillation or inconvenient noises.

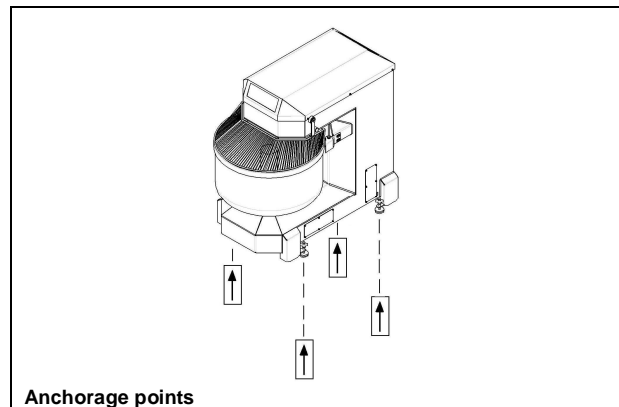

Anchorage points

2.4 - CONNECTING AND ELECTRICAL SUPPLY

	<p>Any intervention to the equipment must be made after the electrical supply cable has been disconnected, however, when working without power is not possible for technical reasons, duly precautions to reduce the risk of electrical shocks and short-circuits must be taken.</p>
--	---

This intervention must be performed by a duly accredited technician. Electrical connection must be made by means of a plug or junction box connectors, from a "neutral TT" line, with a 300mA differential protection.

The electrical power available must comply with the specifications of the properties on the nameplate of the machine.

Mending supply cables is not allowed.

Power strips for phase reversal, 3D power sockets or other adaptation systems are not allowed.

More than one machine connected to the same power source (socket or derivation) is not allowed.

It is necessary to perform an equipotential bonding between machines that share a ferruled ground wire supplementary connection, of a section of at least 6 mm², connected to the exterior screw of this machine identified by the symbol ⊕.

CHAPTER 3

MACHINE USAGE

3.1 - MACHINE CONTROL PANEL

This machine is equipped with a technologically developed control system which controls engines and other electrical equipments. For the machine to run, the following conditions must be respected: Closed grid; emergency button unlocked and main switch on.

	<p>ATTENTION: Control must be performed with a finger. The use of hard or sharp objects may cause unreparable damage.</p>
---	--

There are 3 control options. Check which applies to your machine. When using touch-screen machines, no standby or pause may be activated, it is necessary for the running to actually be stopped. See below how to "stop work".

3.1.1 – Analog control

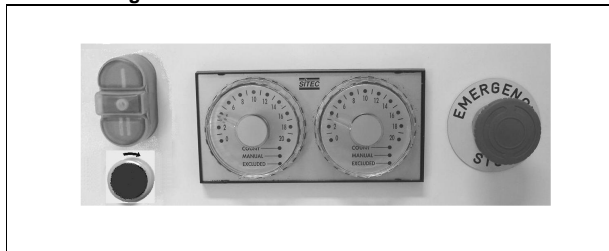

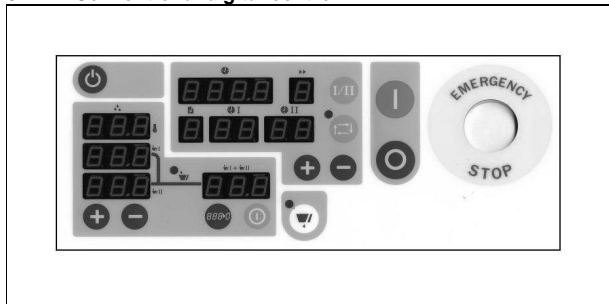

3.1.2 – Conventional digital control

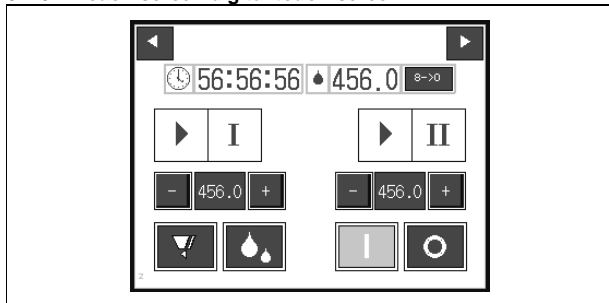

3.1.3 – Touch-screen digital touch-screen



3.1.4 – Emergency stop

<p>CAUTION</p> 	<p>In case of emergency press the emergency button.</p>	
---	---	---

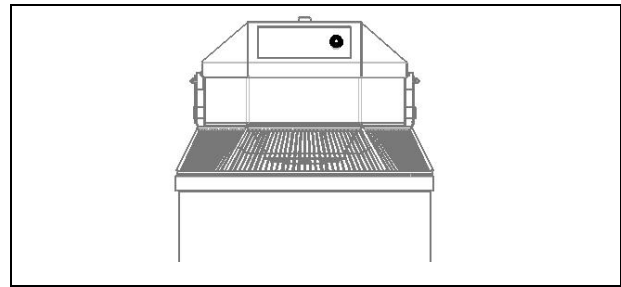

The emergency button must be pressed only when there is the need to stop the machine abruptly, in case of suspicion of damage to the machine, hazard to people's, property's or animals' safety. Do not use this button to stop work under regular conditions, use the stop button

3.1.5 - Ingredient feeding

Open the safety grid;
Proceed with the cleaning operation in accordance with the chapter on daily maintenance in this manual;
Place the ingredients in the bowl;
The feeding of ingredients and the use of adequate hydrant percentages are two very important factors in the fabrication process, as the performance of the machine may depend on these. Good practices must be followed so as not to overwork this machine.

<p>CAUTION</p> 	<p>Attention: closing the grid offers a residual risk of jamming upper body members. Make sure nothing interferes with the closing of the grid.</p>
---	---

Close the safety grid;
Select the intended function on the control.
Whatever your option, select the adequate speed for the product so as to prevent the risk of excessive dust production;

3.2 - FUNCTIONING – ANALOG CONTROL

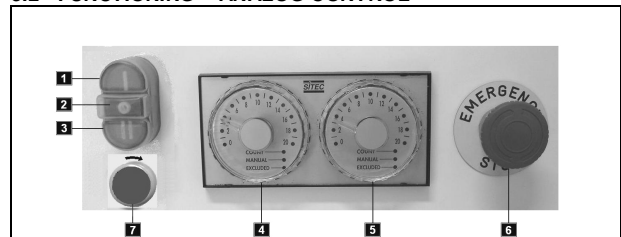



Image caption:

Button	Function
1	Start at low speed
2	Machine stop
3	Start at high speed
4	Low speed time
5	High speed time
6	Emergency stop
7	Rotation to unload the dough
Led	
COUNT	Time counting screening
MANUAL	Manual mode operation
EXCLUDED	Timer out of order

<p>M Main Switch</p>

3.2.1 - Rotation check

This procedure is only applicable to machines which are powered by a three-phase electric power.

Make sure there is nothing inside the bowl apart from the hook.
In models which are equipped with a sequence detection relay and lack of phase, it may happen that when the machine is powered and the main switch is turned on, the panel may not switch on the leds, which implies a lack of phase or means the phases are wrongly sequenced.

In models which are not equipped with sequence detection relays and lack of phase, proceed in the following manner:

Power the machine according to the specifications on the nameplate;

Turn the main switch M of the machine on;

Make sure the grid is closed and the emergency button unlocked;

Set button 4 for a few minutes, 2 for instance.

Press button 1.

The bowl should spin counter-clockwise.

In case that does not happen, stop the machine at 2 and switch the position of two phases. Switch everything on again. This way the machine will rotate in the correct direction, counter-clockwise.

3.2.2 – Working in manual mode

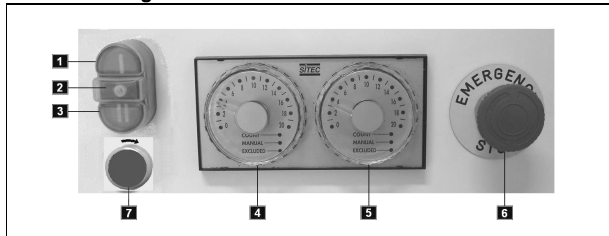

3.2.2.1- Starting the machine

It is necessary for the protection grid to be closed and the emergency button unlocked;

Turn the main Switch M on;

Turn clock 4 until MANUAL led is on.

Press button 1;

After this procedure the machine should start operating at low speed.

3.2.2.2 – Select and screen speeds “1” and “2”

Operating the machine at speed 1 only:

Turn clock 4 until MANUAL led is on.

Turn clock 5 until EXCLUDED is on.

The machine is now ready to be operated at speed 1.

Operating the machine at speed 2 only:

Turn clock 5 until MANUAL led is on.

Turn clock 4 until EXCLUDED is on.

The machine is now ready to be operated at speed 2.

3.2.2.3 – Change speed

Make sure clock 5 MANUAL led of is on.

Having the machine operating at speed 1 press button 3.

The machine will pause and change to speed 2.

3.2.2.4 – Stopping the machine

Manual stop:

Button 2 stops the machine;

Automatic stop:

The maximum work time is 99 minutes, after that the machine automatically stops.

3.2.2.5 – Rotation to unload the dough

The machine must not be operating;

The grid must be closed;

Button 7 activates the hook and bowl on speed “1”;

To stop the movement:

Release button “7”.

3.2.3 - Working in automatic mode

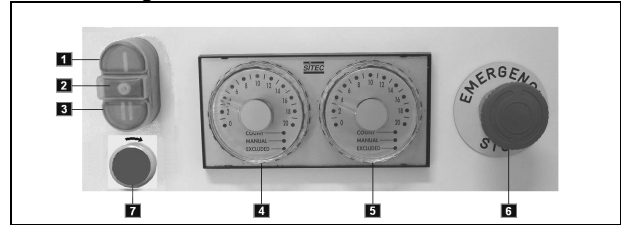

3.2.3.1 – Running a programme

Turn clock 4 to set the work time at speed “1”, for example 2 minutes.

As the pointer of the clock reaches each number, its led goes on. Led by number 2 switches on.

Turn clock 5 to set the work time at speed “2”. For example 10 minutes.

As the pointer of the clock reaches each number, its led goes on. All leds go on up to number 10.

Press button 1.

After 2 minutes operating at speed 1, the machine stops for a short pause and resumes operating at speed 2. While operating led COUNT is intermittent.

When 2 minutes at speed 1 and 10 minutes at speed 2 have elapsed the machine stops.

To run a programme only at speed 1 set the clock 5 so as to have EXCLUDED led on.

To run a programme only at speed 2 set the clock 4 so as to have EXCLUDED led on.

This control does not allow programme saving, each programme is edited and ran at the moment.

3.2.3.2 – Stopping the machine

Manual stop:

Button 2 stops the machine;

Automatic stop:

After the set times in 4 and 5 have elapsed, the machine automatically stops.

3.2.3.3 – Rotation to unload dough

The machine must not be operating;

The grid must be closed;

Button 7 activates the hook and bowl on speed “1”;

To stop the movement:

Release button “7”.

3.3 - FUNCTIONING – CONVENTIONAL DIGITAL CONTROL

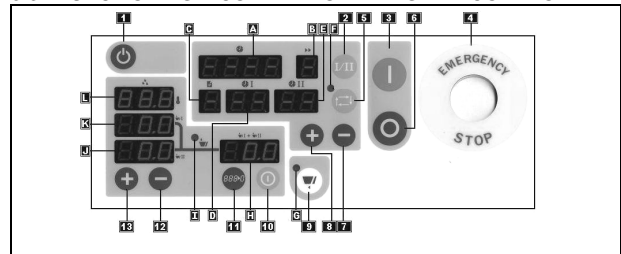
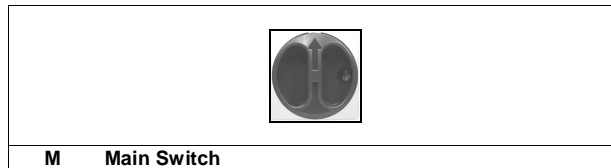

Image Caption:

Button	Function
1	Standby Mode Switch (SM)
2	Speed change at Manual Mode (MM)
3	Starts the machine, engines of the bowl and hook simultaneously
4	Emergency stop
5	Automatic Mode selection (AM)
6	Stops the engines of the bowl and the hook simultaneously, as well as the water meter.
7	Reduces the figures on displays C, D and E
8	Increases the figures on displays C, D and E
9	Reversal of the rotation of the bowl! – (optional function)
10	Switches the meter on and off – (optional function)
11	Resets display H – (optional function)
12	Decreases figures on displays J, K – (optional function)
13	Increases figures on displays J, K – (optional function)

Display	Function
A	Time information (minutes.seconds)
B	Work speed (1 to 2)
C	Programme number (1 to 9)
D	Automatic Mode (AM) Elapsed time at low speed "1" (minutes)
	Manual Mode (MM) Elapsed time at low speed "1" (minutes)
E	Automatic Mode (AM) Elapsed time at high speed "2" (minutes)
	Manual Mode (MM) Elapsed time at high speed "2" (minutes)
H	Water discharged into the bowl – (Optional function) (litres.declitres)
J	Amount of water selected for speed "2" – (Optional function) (litres.declitres)
K	Amount of water selected for speed "1" – (Optional function) (litres.declitres)
L	Water temperature in the meter (Celsius ou Fahrenheit) – (Optional function)
Led	Function
F	Function indicator (button 5 ON)
G	Function indicator (button 9 ON) – (Optional function)



3.3.1 - Rotation check

This procedure is only applicable to machines which are powered by a three-phase electric power.

Make sure there is nothing inside the bowl apart from the hook.

In order for the machine to operate it must be on and power supplied as described complying with the following terms:

Main switch on, emergency button unlocked and closed grid.

Turn the main switch M of the machine on;

Press button 1 before 3.

The bowl should spin counter-clockwise. In case that does not happen, stop the machine on 6, press 1 and turn off the main switch M. Unplug the machine and switch two phases. Switch everything on again. This way the machine will rotate in the correct direction, the bowl will rotate clockwise.

3.3.2 – Choosing work mode

Power the machine according to the specifications on the nameplate.

Switch the main switch M on;

Make sure the grid is closed and the emergency button is unlocked;

All displays will screen number 8 for 2 seconds;

All led will be switched on for 2 seconds.

Simultaneously a continuous beep sounds (for 2 seconds).

The control is on standby.

Change from standby mode to manual

Press button 1.

Change from manual mode to automatic

Press button 5.

Start programming mode

In automatic mode hold button 5 pressed until information "Prog." comes up on display A

Change from automatic mode to manual

Press button 5.

Start standby mode

In manual or automatic mode, press button 1.

Adding water in standby – optional function

See working in standby mode.

Switch off the machine

Press button 1;

Switch off main switch M.

3.3.3 - Working in standby mode

In standby only the water meter can be operated (optional function).

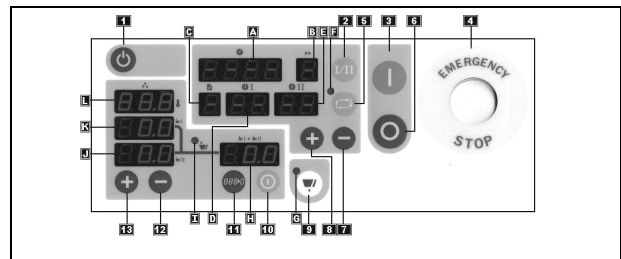

Display L assumes the current water temperature.

Change Display L from Celsius to Fahrenheit:

Led I must be switched off;

Press button 11 for 3 seconds;

Display L screens "C" for Celsius;

Press button 11;

Display L screens "F" for Fahrenheit;

3 seconds later it automatically assumes the "F" figure selected;

Display L screens the water temperature again.

To adjust K:

Press button 12 or 13.

To start working with the meter:

Press button 10;

The meter automatically stops when display H reaches the figure in display K.

To pause during discharge:

Press button 10.

To resume:

Press button 10 again.

After a pause or a stop, o display H may be brought to zero by pressing button 11.

During discharge:

Display I stays on and K is intermittent;

Display H increases;

Display K maintains the selected figure.

To redefine the figure in display K:

Adjust buttons 12 or 13;

In case of shortage of water:

The valve switches off after 10 seconds;

Display A screens "H2O";

Display I switches off.

3.3.4 - Working in manual mode

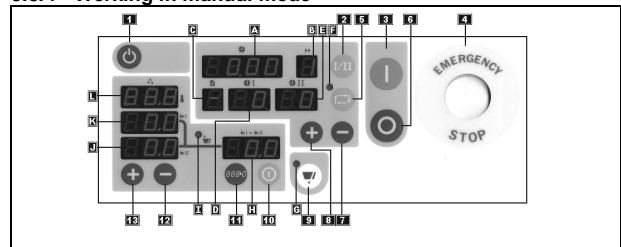

3.3.4.1 – Starting the machine

It is necessary to have the protection grid closed and the emergency button unlocked;

Switch on main switch M;

Press button 1;

Press button 3;

With this procedure the machine starts running in manual mode at low speed.

B screens the functioning speed.

A screens the instantaneous ascending elapsed time.

3.3.4.2 – Selecting and seeing speed "1" and "2"

Having the machine stopped and led F switched off;

By pressing button 2 speed "1" or "2" is selected.

Display B screens speed "1" or "2".

3.3.4.3 – Changing speed

To change speed from "1" to "2":

At any time, by pressing button 2, speed "1" stops, and after a pause, speed "2" starts.

To change from speed "2" to "1":

Stop the machine by pressing button 6;

Press button 2 to change display B from "2" to "1";

Press button 3 to start the machine at speed "1".

3.3.4.4 – Screening elapsed time

Display A indicates the elapsed time in progress at speed "1". After changing from speed "1" to speed "2", display A sums the elapsed time at speed "1" and the time in progress at speed "2". Display D and E screen the elapsed time at speed "1" and "2" respectively.

3.3.4.5 – Bowl reversal at speed "1" (optional function)

During work at speed "1";
Display B must screen "1"
Display A (elapsed time) must be greater than one second and less than 59 seconds;
Press button 9;
The machine stops the bowl and the hook and pauses;
Then, it starts the bowl reversal (speed "1" and simultaneously starts the regular rotation of the hook at speed "1", for one minute;
Led G is switched on;
Display A continues the elapsed time (display A sums the regular rotation time and the reversal time)
A minute later (rotation reversal), the machine stops the bowl and the hook, pauses, then resumes the regular rotation of the bowl and the hook.
To stop the bowl reversal:
Press button 9;
Led G switched off;
The machine stops the bowl and the hook;
It pauses;
Then resumes the regular rotation of the bowl and the hook.
To change to speed "2".
Press button 2 during the reversal of the bowl;
Led G switches off;
The machine stops the bowl and the hook;
It pauses;
Display B screens "2";
Display A continues the elapsed time.
During work at speed "2" it is not possible to operate the reversal of the bowl.

3.3.4.6 – Bowl reversal during discharge – (optional function)

The machine must not be operating;
The grid may be closed or open;
Button 9 inverts the rotation of the bowl (the hook remains stopped);
Hold button 9 pressed;
Led G remains off;
Display A does not change during this operation.
Reversal of the rotation happens at speed "1".
To stop the reversal:
Release button 9.

3.3.4.7 – Adding water – (optional function)

This operation may be performed while the machine is running or stopped, at slow or high speed.
Assure the grid pressure is between 0,25bar (25KPa; 3,6Psi) and 5bar (500KPa; 72,5Psi).

At first speed

Speed 1 is selected in "5"

To adjust the intended amount in "12" Press "10" or "11" to reduce or increase amount, respectively.

To initiate discharge press "9";

The total amount of already discharged water is screened in "16".

The discharge automatically stops when "16" reaches the intended amount in "12".

To pause during discharge:

Press "9".

To resume discharge:

Press "9" again.

The figure in "16" may be brought down to zero at any moment by pressing "17".

During discharge button "9" is intermittent and in "16" the figure is increased.

At second speed

Speed 2 is selected in "6"

To adjust the intended amount in "15" press "13" or "14" to reduce or increase amount, respectively.

To initiate discharge press "9".

Discharge automatically stops when "16" reaches the intended amount set in "12".

To pause during discharge:

Press "9".

To resume discharge:

Press "9" again.

The figure in "16" may be brought down to zero at any moment by pressing "17".

During discharge, button "9" is intermittent and in "16" the amount is increased.

In case of water failure:

The water discharge valve switches off after 15 seconds;

The message "?H2O" is screened

To resume, press on the message and it will be deleted.

To try to discharge water again:

Press "9".

Water flow adjustment

When "5" is selected the discharge flow equals the water flow inserted into the machine.

When "6" is selected the discharge flow may be adjusted from the water flow insertion to the reduced flow, commonly called "trickle of water"

To discharge water in a reduced flow, adjust the tap by the meter during discharge.

Measurement error

Readings of water litres metering may have a variation of $\pm 5\%$ in flows between 0,5l/min and 2l/min and $\pm 2\%$ for flows between 2l/min and 20l/min. The water temperature is instantaneous and measured on the water control box, inside the machine. To measure the water temperature in the supply deposit or on the grid, an auxiliary thermometer, with own reading and separated from the machine, will have to be used.

3.3.4.8 – Stopping the machine

Manual stop:

Button 6 stops the machine;

The water meter stops immediately;

Display I switches off;

Information on displays A, B, D, E, H, J, K is saved.

Automatic stop:

The maximum work time on the display is 99 minutes and 59 seconds, after that, it automatically stops.

The meter automatically stops;

Display I switches off;

Information on displays A, B, D, E, H, J, K is saved.

To bring time on displays A, D, E and H to zero after having stopped the machine:

Press button 6;

Displays A, D, E and H change to zero

Display B changes to "1"

The machine is now ready for a new operation.

3.3.5 - Working in automatic mode

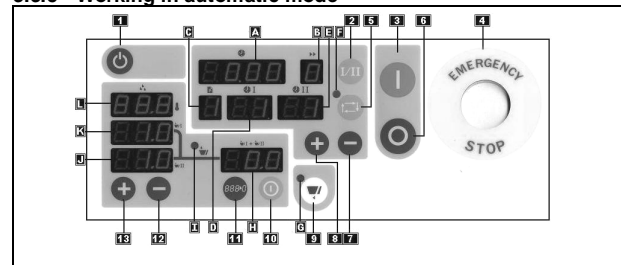

3.3.5.1 – Starting the machine

It is necessary to have the safety grid closed and the emergency button unlocked;

Turn on the main switch M;

Press button 1;

Press button 5;

Press button 3;

After this procedure the machine starts on automatic mode, on the saved n° 1 programme. (if it is equipped with a water meter, the programmed water discharge happens at speed 1).

3.3.5.2 – Programme editing

Programmes are saved on a 9 programme invariable memory.

Press button 5 for 3 seconds:

The word "Prog" is intermittent on display A;

Led F is intermittent;
 Display C is intermittent;
 Buttons 7 and 8 adjust display C;
 Press button 5 to go to display D;
 Display D is intermittent;
 Buttons 7 and 8 adjust display D;
 Press button 5 to go to display M; (*)
 Display K is intermittent;
 Buttons 7 and 8 adjust display K. (*)
 Press button 5 to go to display E;
 Display E is intermittent;
 Buttons 7 and 8 adjust display E;
 Press button 5 to go to display J; (*)
 Display J is intermittent;
 Buttons 7 and 8 adjust display J. (*)
 (*) – Optional function. Equipment which is not supplied with this function does not allow display change.

3.3.5.3 – Programme saving

Press button 5 for 3 seconds;
 A beep sounds and the word "SAVE" is screened on display A;
 This programme has been saved.
 It is now possible to run or alter this programme or even change any other programme.

3.3.5.4 – Programme running

Led F must be on;
 Buttons 7 and 8 select the saved programme;
 Display C screens the intermittent programme number;
 Button 3 starts the Automatic Mode (AM) on the programmed cycle;
 Valve "1" opens; (*)
 Make sure the network pressure is between 0,25bar (25KPa; 3,6Psi) and 5bar (500KPa; 72,5Psi).
 Display I switches on; (*)
 Display K is intermittent; (*)
 During discharge: (*)
 To redefine the figure saved on display K, use buttons 12 and 13;
 Display H increases until the figure on display K is reached. (*)
 Speed "1" valve stops. (*)
 Display I switches off. (*)
 (It is possible to run programmes while display K screens "0.0").
 To start the machine while the water discharge is happening, press button 3 twice.
 After the water discharge stops, the machine starts automatically at speed "1".
 Display D turns intermittent.
 Display B screens speed "1".
 When display A reaches the set time on display D,
 Speed "1" switches off;
 It pauses;
 It automatically changes to speed "II":
 At the same time, a continuous 3 second beep sounds.
 (In case the amount on display K is not yet on display H, display K must be discharged)
 Display E turns intermittent;
 Display B screens the change between speed "1" and "2".
 Display A screens the sum of elapsed time at speed "II" and "I".
 Display D continues to screen the elapsed time at speed "I".
 To add water:
 (It is possible to run programmes while display J screens "0.0").
 Press button 10;
 Speed "2" valve opens; (*)
 Display I switches on; (*)
 Display J turns intermittent; (*)
 Display H increases while the sum of displays J and K is not reached; (*)
 Speed "2" valve stops; (*)
 Display I switches off. (*)
 The machine continues the automatic cycle at speed "II".
 During discharge:
 To redefine the saved figure on display J, use buttons 12 and 13;
 Button 11 (when display I is off), sets display H to zero.
 During a programme execution, changes can be made at any time, by pressing buttons 7, 8, 10, 11, 12, 13. At the end of the cycle, those changes will not be saved. The saved figures are unchanged.
 During work at speed "1"
 Press button 7
 If (the figure on D is less than the figure on display A):
 The machine changes to speed "2".

During work at speed "2".
 Press button 7
 If display E is less than the difference between display A and D:
 The machine stops.
 In case of water shortage: (*)
 Speed valve "I" switches off after 10 seconds;
 The programme does not continue;
 Display A screens message H2O.
 Display I switches off;
 To resume the cycle, press button 3 twice.
 Display A continues counting.
 To try to discharge water:
 Press button 10.
 (*) – Optional function. Equipment which is not supplied with this function performs the next step.

Flow adjustment

To add a trickle of water at speed "2", set the tap next to the meter while discharging.

Measurement error

Counting of water litre readings may vary $\pm 5\%$ on flows from 0,5l/min to 2l/min and $\pm 2\%$ on flows from 2l/min and 20l/min. Water temperature is instantaneous and is measured on the water control box, inside the machine. To measure the water temperature in the supply or network deposit an independent, separated from the machine, auxiliary thermometer will have to be used.

3.3.5.5 – Seeing work time

Display A indicates the elapsed time at speed "I" in progress.
 After changing from speed "I" to "II":
 Display A sums the elapsed time at speed "I" to the elapsed time at speed "II" in progress.
 Display D and E screen the final elapsed time for speed "I" and "II" respectively.
 The final elapsed time may differ from the saved figure because:
 During the programme execution, changes may be made at any time by pressing buttons 7, 8, 10, 11, 12, 13. At the end of the cycle, these changes will not be saved. The figures priority saved are unchanged.

3.3.5.6 – Bowl reversal at speed "1" (optional function)

During work at speed "1";
 Display B must be at "1";
 Display A (elapsed time) must be greater than a second and less than 59 seconds;
 Press button 9;
 The machine stops the bowl and the hook and pauses;
 After that, bowl reversal is initiated (speed "II") and simultaneously starts with the hook at regular work rotation (speed "I") for a minute
 Led G is on;
 Display A continues elapsed time (Display A sums the regular rotation time and the bowl reversal time);
 After a minute has passed (bowl reversal), the machine stops the bowl and the hook, pauses and starts a regular cycle on Automatic Mode (AM).
 Manual stop of bowl reversal:
 Press button 9,
 Led G switches off,
 The machine stops the bowl and the hook;
 It pauses,
 After that, the machine resumes the regular cycle on Automatic Mode (AM), as selected.
 During work at speed "II";
 This operation is not possible.

3.3.5.7 – Bowl reversal during discharge – (optional function)

The machine must be stopped;
 The grid must be open or closed;
 Button 9 reverses the rotation of the bowl (the hook remains stopped):
 Keep button 9 pressed;
 Led G is ON
 Display A does not change during this operation.
 Rotation reversal happens at speed "I".
 To stop the reversing:
 Stop pressing button 9.

3.3.5.8 – Adding water – (optional function)

Water discharge (speed "I") is automatic before the start of the machine.





Water discharge (speed "II") is manual during speed "I".
Check programme execution in automatic.

3.3.5.9 – Stopping the machine

Manual stop:
Button 6 stops the machine;
Meter stops immediately;
Saves information on A, B, C, D, E, F, H, J, K, L. (*)
Pressing button 3 the machine resumes:
Display A continues to increase time.
Automatic stop:
At the end of the cycle:
Meter stops automatically;
Saves information on display A, B, C, D, E, H, J, K, L; (*)
Display C is intermittent;
Display A screens "Done" for 3 seconds;
Display B screens "0";
Display D screens elapsed time at speed "I";
Display E screens elapsed time at speed "II";
Display H screens discharged water (sum of display K and J); (*)
Display K screens water amount at speed "I"; (*)
Display J screens water amount at speed "II"; (*)
Display I switches off (*)
To delete time on displays A, D, E and H. (*)
Press button 6;
Display A and H change to "0.0"; (*)
Other displays maintain as programmed;
To repeat the previous programme:
Press button 3;
The machine repeats previous programme.
To start a new programme:
Select the programme number (button 7 or 8);
Press button 3.
The machine starts as selected.
(*) – Optional function. Equipment which is not supplied with this function performs the next step.

3.3.5.10 – Messages

There are messages to support the user, which do not stand for a failure. They come on display 3 as such:

Message on Screen	Cause
	On Manual Mode (MM) or Automatic Mode (AM): Safety grid open.
	Successful programming mode start (Automatic Mode (AM))
	Successfully exit and saving of programming mode (Automatic Mode (AM))
	Water entrance failed to enter the counter. (Optional function.)
	Programme cycle is over.

At machine failure situations, an error message may come up on the control screen. Whether the message is screened or not, before contacting accredited by the manufacturer Technical Support, replacing any component or proceeding with operation, switch off the machine on the main switch and unplug the cable from the electrical supply. Hold for about 5 minutes and switch it on again. If the problem has been due to an ephemeral cause, it will go away. Next are some possible failures and eventual solution.

<p>Erro</p> 	<p>Thermal relay protection activated. Effort of the machine, by activation of engine thermal protection, caused either by effort of kneading harder dough or by friction. Turn the machine off on the main switch. Reduce the load in the machine. Switch on the machine and resume work.</p>
--	--

3.4 - FUNCTIONING – TOUCH-SCREEN DIGITAL CONTROL

3.4.1 - Rotation direction check

This procedure only applies to machines that have a three-phase power system.
Make sure there is nothing inside the bowl apart from the hook.
In order for the machine to operate it must be switched on and powered according to the described in the following conditions:
Main switch on, emergency button unlocked, bowl in working position and closed grid.
Turn on the main switch M.
The logo should be screened, as generically presented below:

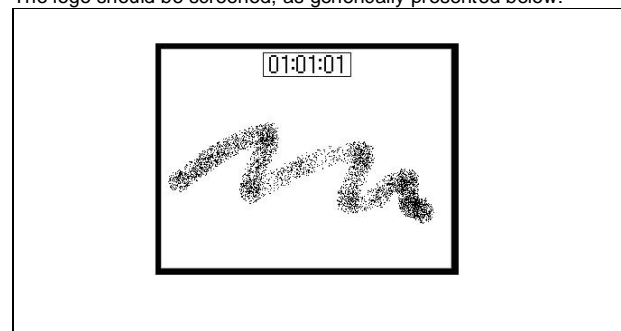

Immediately and automatically, it will change to the following screen, which is a manual mode work screen. This sequence means the machine has successfully started and is now ready to operate.

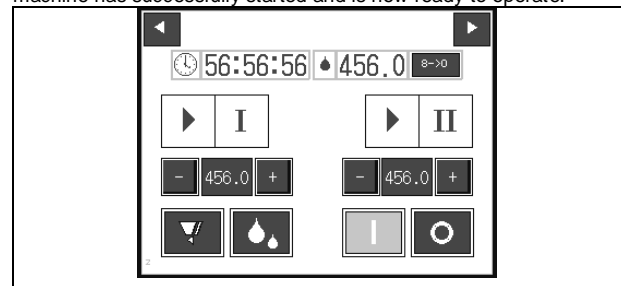

On models which have no sequence detection relay and lack of phase, proceed in the following manner:
Press button 4;
The bowl must rotate counter-clockwise.
Should this not happen, stop the machine on 3 and turn off the main switch. Unplug the power supply and switch the position of two phases. Reconnect everything to have the machine rotating in the correct direction, counter-clockwise.
On models with sequence detection relay and lack of phase, a message will inform of the lack of one or two phases and even if the phases are switched. In this case, turn off the main switch, unplug the power supply and switch the position of two phases. Reconnect everything to have the machine rotating in the correct direction, counter-clockwise.

3.4.2 – Choosing work mode

From manual mode to automatic

On manual mode screen press button “2”.

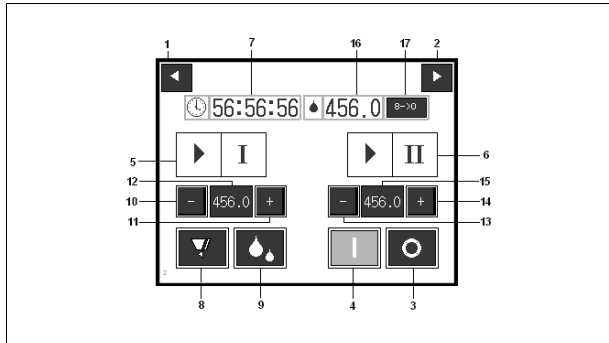

The following screen is the one of programme selection:

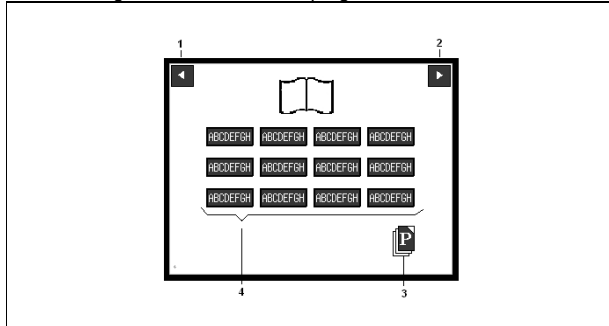

Press an area 4 programme to go to automatic work screen:

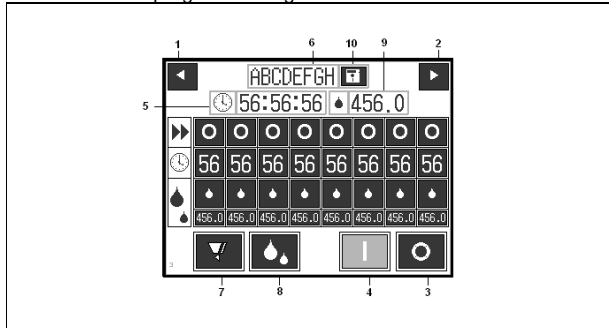

Enter programming mode

On the programme selection screen press button “3”:

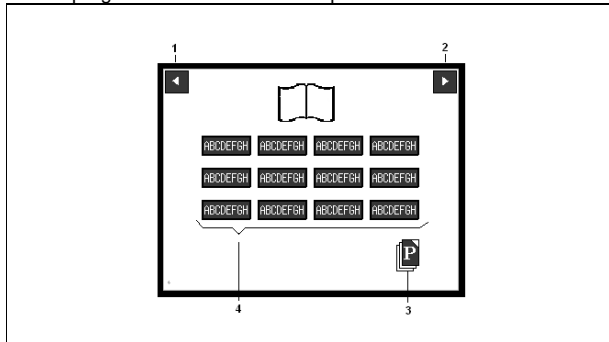

There are 12 editable programmes; to go through each press “1” and “2”, viewing the programme number on “3”:

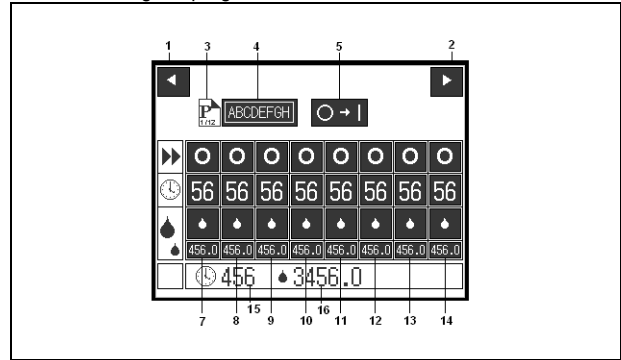

From automatic mode to manual

On automatic mode screen press button “1”.

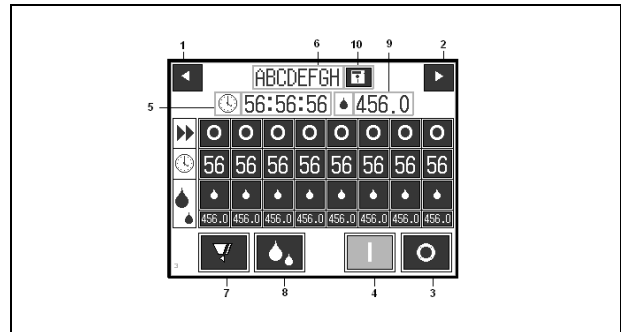

Switch off the machine

On any screen, while the machine is stopped, switch off the main switch “M”.

3.4.3 - Working in manual mode

It is necessary to have the protection grid closed and the emergency button unlocked;

It is possible to work at low speed, in “5”, also called first speed, or at high speed in “6” also called second speed.

Turn the main switch “M” of the machine on;

After the start and the automatic logo screen, press button “4”.

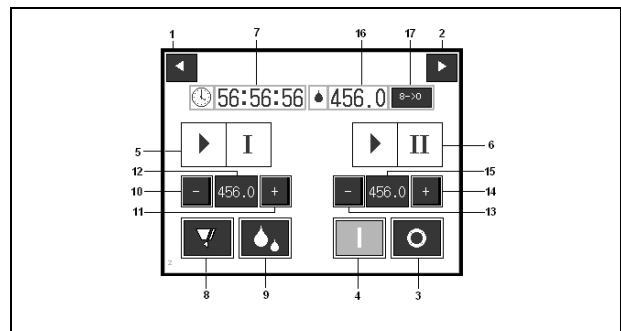

This procedure should get the machine to operate on manual, at low speed by default.

The speed is highlighted in “5” by an intermittent frame around it. In “7” ascending elapsed time is screened (hh:mm:ss)

From low speed to high speed

Press “6”;

High speed is highlighted in “6” by an intermittent frame around it.

In “7” accumulated elapsed time is still screened.

From high to low speed

Press button “3” to stop work or lift the protection grid and close it again;

Press “5” to select low speed

Press “4” to initiate low speed.

Pause the work

At any moment, at first or second speed, press "3", or;
Lift the protection grid.
Time is saved in "7".

Resume work

The grid must be closed;
Press "4";
The time screened in "7" continues to increase

Stop work

At any moment, at first or second speed, press "3" twice;
The elapsed time screened in "7" is brought down to zero.
On manual mode, after about 3 hours and 20 minutes of accumulated work, the machine will automatically stop.

3.4.3.1 – Adding water – optional function

Unavailable function in this machine.

3.4.3.2 – Bowl reversal – optional function

a) Having the machine operating, during the first minute, in first speed, with the grid closed:

Press "8".
The bowl stops rotating and starts a one minute rotation counter-clockwise.

The hook continues rotating counter-clockwise.
The time screened in "7" stops counting.
If you wish to interrupt this reversing simply press button "8" once again and the machine resumes its work at first speed.
Should there be no instruction, when one minute has passed, the bowl stops and resumes its counter-clockwise rotation. The hook continues at counter-clockwise rotation.

b) Having the machine stopped, the grid open or closed: Keep button "8" pressed.

The bowl rotates clockwise and the hook remains stopped.
To stop the reversing release button "8".

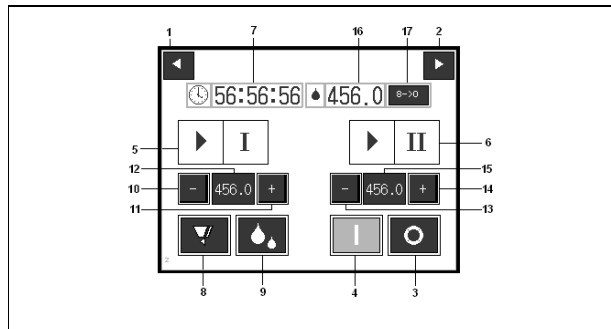

3.4.4 - Working in automatic mode

It is necessary for the protection grid to be closed, the emergency button unlocked and the screen on automatic mode:

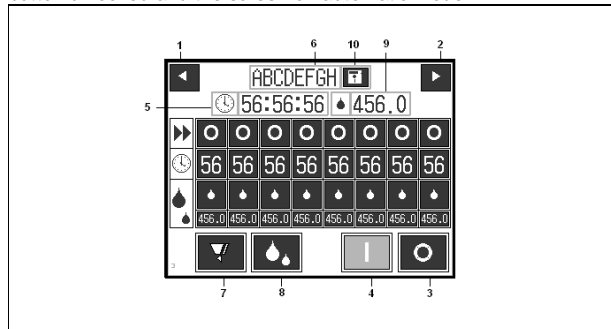

On the following picture, it is necessary to do a table reading, by matching information on rows and columns.

Row "B" contains first speed "I", or second speed "II" or even a pause "O". For example, first speed in "B1" operates throughout time in "C1".

Row "C" contains the time programmed for work or pause in minutes.

Row "A" contains the amount of water to be discharged in maximum flow "●" or in reduced flow "●".

The amount to be discharged is set below the drop in "litres.declitres".

Unless a drop is selected water will not be discharged (even if the amount to be discharged is higher than zero).

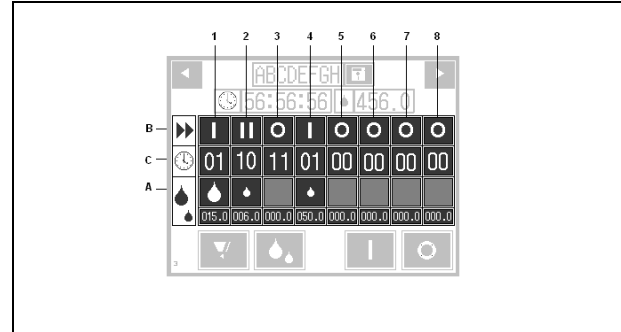

Image caption for the used symbols:

Position "C1" means the machine will work for 1 minute
Position "B1" means the machine will work at first speed
Position "A1" means the machine will discharge 15 litres of water in maximum flow.

When time in "C1" is finished column "2" will automatically go into operation. In this column position "B2" means the machine will work on second speed and position "C2" means the machine will work for 10 minutes.

Position "A2" means the machine will discharge 6 litres of water in reduced flow.

When time in "C2" is finished, operation will automatically change to column 3. In this column position "B3" means the machine will not work but pause, and position "C3" means it will continue for 11 minutes.

Note:

- 1- When time defined in row "C" is zero, it means this row will be inactive.
- 2- If all times in row "C" are zero it means the machine will not work.
- 3- Position "B1" for security matters maintains figure "1".
- 4- If by any chance two similar speeds are defined, in two sequential columns, the movements of the machine remain unaltered when the first time ends.

3.4.4.1 – Selecting a programme

To select the programme, simply press the name to go on operation in area "4".

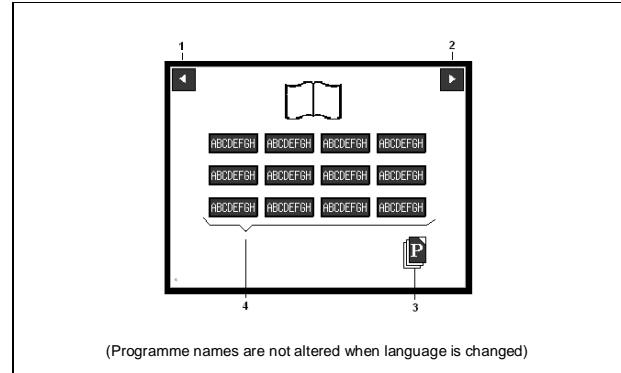

(Programme names are not altered when language is changed)

Progression to automatic screen is immediate.

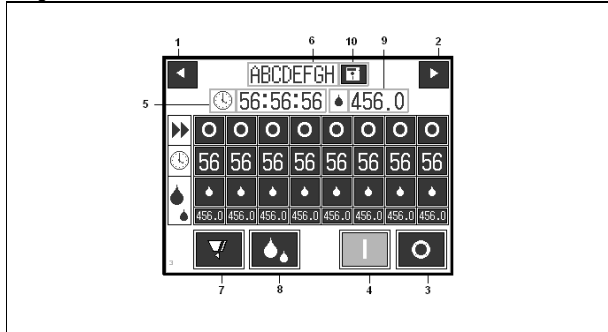

Changing time during work

Press the time you wish to change, use the digital keyboard that comes on screen to insert a new figure and press "ENT".

Changes can be saved on the original programme at any moment by simply pressing "10"

Change to high speed

This operation is made automatically at the end of the time set at low speed if the following speed is higher.

When the time is adjusted to zero it means the related speed will not work and will immediately operate at the next speed.

In "5" ascending total elapsed time is screened.

Change from high to low speed

This operation is automatic, at the end of the selected time at high speed is the following speed is lower.

Pause the work of the machine

At any time, at first or second speed, press "3", or; Lift the protection grid.

Time recorded in "5" is kept.

Resume work

The grid must be closed;

Press "4";

Stop work

At any time, at first speed, pause or second speed, press "3" twice;

Adding water – optional function

This operation can be performed while the machine is either stopped or running, at slow or high speed.

Press "8".

The total amount of water to be discharged is screened on "9".

During a programme run the water discharge is automatic.

Assure the pressure of the grid is between 0,25bar (25KPa; 3,6Psi) and 5bar (500KPa; 72,5Psi).

Press "8" to stop discharge at any moment.

In case of water failure:

The water discharge valve switches off after 15 seconds;

The message "?H2O" is screened.

To resume, press the message and it will be deleted.

To try to discharge water again:

Press "8".

Water flow adjustment

When "H" is selected, the discharge flow equals the water flow inserted into the machine.

When "L" is selected the discharge flow may be adjusted from the inserted water to the reduced flow, commonly called "trickle water".

To discharge water at a reduced flow, adjust the tap next to the meter during discharge.

Water discharge during the last time of the programme

When there is not enough time to debit the total amount of water, discharge is interrupted by the programme for 30 seconds before ending. The message "?H2O" is screened.

Measurement error

Readings of water litres metering may have a variation of $\pm 5\%$ in flows between 0,5l/min and 2l/min and $\pm 2\%$ for flows between 2l/min and 20l/min. The water temperature is instantaneous and measured on the water control box, inside the machine. To measure the water temperature in the supply deposit or on the grid, an auxiliary thermometer, with own reading and separated from the machine, will have to be used.

3.4.4.2 - Altering or installing programmes

Access the programmes screen.

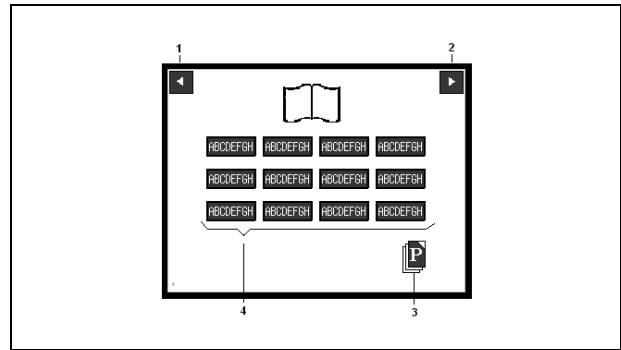

Press "3" to go to each programme editing, shown next.

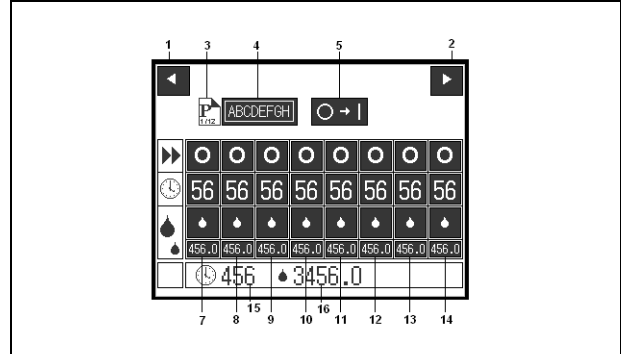

In area "3" is the programme number "#" followed by the total number of programmes "#n"; in this case it is possible to edit programme 1 out of 12;

Press "2" to move forward to the programme number you wish to alter;

Press "4" to adjust the name of the programme;

Example of a programme with 4 sequences of 2 speeds and pauses

Press "7" to adjust the time for the first sequence at low speed; the water litres and discharge flow.

Press "8" to adjust the time for the first sequence at high speed or pause; the water litres and discharge flow.

Press "9" to adjust the time for the second sequence at low speed, high speed or pause; the water litres and discharge flow.

Press "10" to adjust the time for the second sequence at low speed, high speed or pause; the water litres and discharge flow.

Press "11" to adjust the time for the third sequence at low speed, high speed or pause; the water litres and discharge flow.

Press "12" to adjust the time for the third sequence at low speed, high speed or pause; the water litres and discharge flow.

Press "13" to adjust the time for the fourth sequence at low speed, high speed or pause; the water litres and discharge flow.

Press "14" to adjust the time for the fourth sequence at low speed, high speed or pause; the water litres and discharge flow.

Save programme according to the description ahead.

Example of a programme with a sequence of two speeds – conventional programme

Press "7" to adjust the time for the first sequence at low speed; the water litres and discharge flow.

Press "8" to adjust the time for the first sequence at high speed; the water litres and discharge flow.

Press "9" to bring time to zero;

Press "9" to bring time to zero;

Press "10" to bring time to zero;

Press "11" to bring time to zero;

Press "12" to bring time to zero;

Press "13" to bring time to zero;

Press "14" to bring time to zero;

Programme saving

Press "6" to save changes, in each programme.

The programme is saved, ready to be operated in automatic mode.

NOTE: If you exit the programme you have changed, by pressing buttons "1" or "2", without saving, the changes will not be saved.

To go straight to the automatic mode screen and run the programme you have just saved, press "5".

3.4.4.3 – Bowl reversal - optional function

a) Having the machine operating for the first minute, at first speed, with the grid closed:

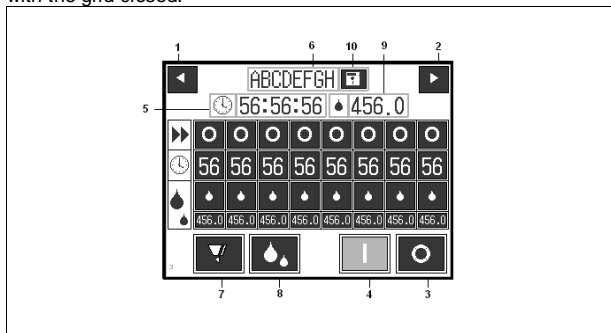

Press "7".

The bowl will stop the rotation and start a minute-long rotation clockwise.

The hook continues rotating counter-clockwise.

Time screened in "5" continues counting.

If you wish to interrupt this reversing simply press button "7" again and the machine shall resume its work at first speed.

If no interruption occurs after the first reversing minute, the bowl stops and resumes its counter-clockwise rotation. The hook maintains at counter-clockwise rotation.

If the time set for speed 1 equals 1 minute, the reversal time is the difference between 1 minute and the elapsed time at speed 1.

b) Having the machine stopped, with the grid open or closed:

Continuously press button "7".

The bowl rotates clockwise and the hook remains still.

To stop reversing release "7".

3.4.5 – Language selection screen

Press button "2" on the programme selection screen

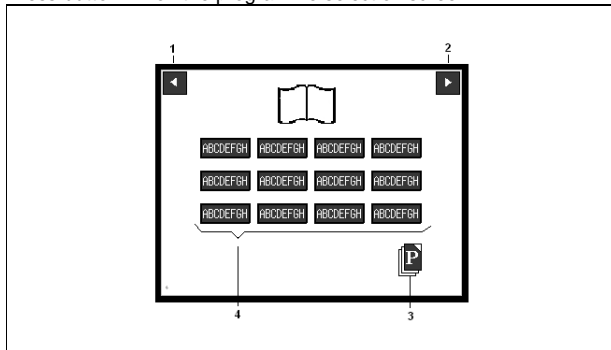

This is the language selection screen:

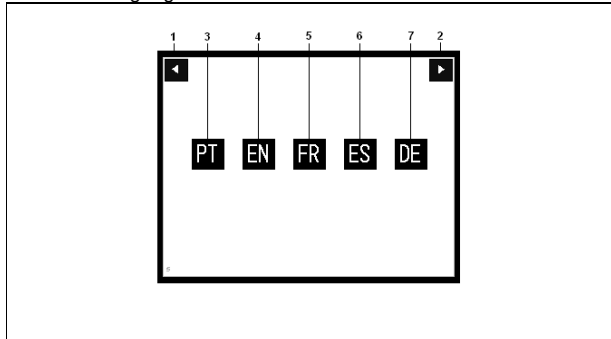

Press "3" to select Portuguese.

Press "4" to select English.

Press "5" to select French.

Press "6" to select Spanish.

Press "7" to select German.

The selected language is by default the one last used in the machine.

Button "1" returns to the programme selection screen and button "2" forwards to the equipment usage screen.

3.4.6 – Equipment usage screen

This is the equipment usage screen:

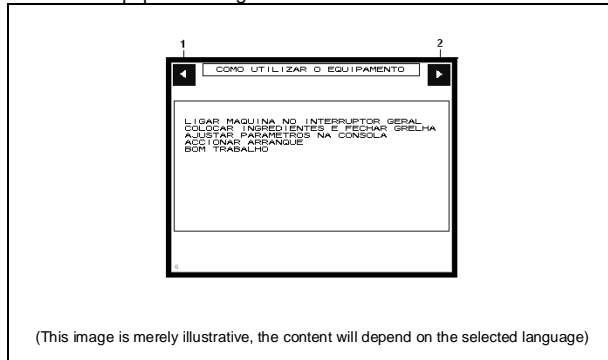

(This image is merely illustrative, the content will depend on the selected language)

Button "1" returns to the language screen.

Button "2" forwards to other products disclosure screen.

In this screen the functioning of the machine is very briefly described. The operating procedure described in this manual must be fully respected and applied.

3.4.7 – Other products disclosure screen

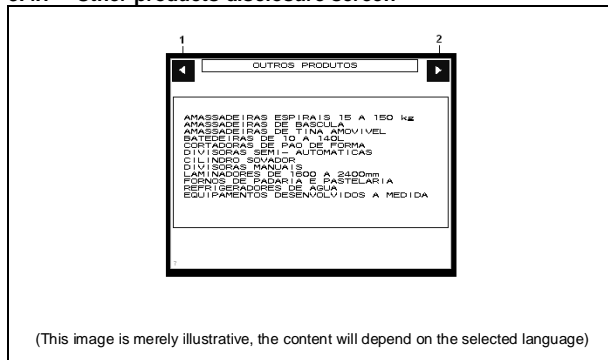

(This image is merely illustrative, the content will depend on the selected language)

Button "1" returns to the equipment usage screen.

Button "2" forwards to the entries and exits screen.

This screen offers a shortened list of some equipment manufactured and commercialised by the company.

3.4.8 – Entries and exits state and counter screen

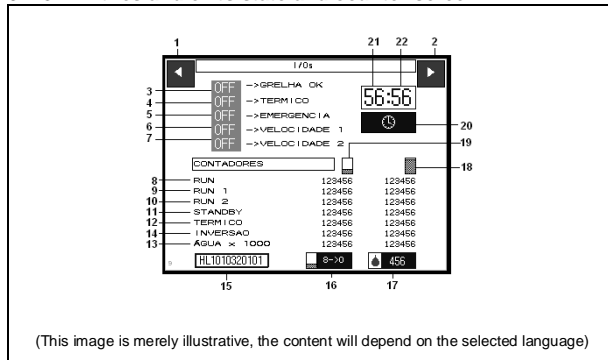

(This image is merely illustrative, the content will depend on the selected language)

Button "1" returns to the other products screen.

Button "2" forwards to the logo screen of the company.

This screen offers a list of electrical entries and exits that support maintenance operations.

Row 3 – grid signal state

Row 4 – thermal relay sign state

Row 5 – emergency sign state

Row 6 – first speed powered engines sign state.

Row 7 – second speed powered engines sign speed.

Row 8 – total elapsed hours of the machine, that is, the amount of hours in which the machine has actually been operating.

Row 9 – total elapsed hours of the machine at first speed, that is, the amount of hours in which the machine has actually been operating in first speed.

Row 10 – total elapsed hours of the machine at second speed, that is, the amount of hours in which the machine has actually been operating at second speed.

Row 11 – stop hours of the machine, that is, hours in which the machine has not been operating.

Row 12 – number of triggers of at least one engine thermal relay.

Row 13 – number of cubic metres of discharged water. Row 14 – number of performed reversals.

In columns “18” and “19” respectively are offered the total amounts and partial amounts of the contents in lines “8” to “14”.

In area “15” the control software version of the machine can be checked.





Button “16” is authorised to the manufacturer only.

Button “17” is accessed only by the manufacturer.

To change the time in the initial logo screen, press “20”. The area 21 and 22 will be highlighted by and intermittent frame. Press now on what you intend to change, hours “21” and minutes “22”. In the end press “20” again to accept changes.

3.4.9 – Messages

During the operating of the machine there are messages to the user.

Message	Description	What to do
 <p>(This image is merely illustrative, the content will depend on the selected language)</p>	Safety grid open	Regular use, close grid if necessary
	Safety grid closed	Tune or replace the end of course
 <p>(This image is merely illustrative, the content will depend on the selected language)</p>	Emergency button pressed	Unlock emergency button if necessary
	Emergency button unlocked	Check connections or replace button
 <p>(This image is merely illustrative, the content will depend on the selected language)</p>	Trigger of the engine thermal protection, caused by effort of working with harder dough; or by friction.	Reduce the load of the machine. Try to repeat the work. Should it repeat, contact accredited by the manufacturer Technical Support.
	The machine is pausing to allow the dough to rest.	No intervention is necessary. The machine will resume the programme automatically.
		

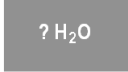
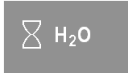
	There is a failure in the water supply of the machine.	Press the message to delete it. Assure correct water supply.
	There is water supply but there is not water discharge.	Contact accredited by the manufacturer Technical Support.
	The water discharge has been interrupted by the programme 30 seconds before its finish. There is not enough time to debit the total amount of water.	Press the message to delete it. No intervention is necessary. Allow the programme to finish.

At machine failure situations, before contacting accredited by the manufacturer Technical Support, replacing any component or proceeding with operation, switch off the machine on the main witch and unplug the cable from the electrical supply. Hold for about 5 minutes and switch it on again. If the problem has been due to an ephemeral cause, it will go away.

3.5 - FAILURE DETECTION AND SOLVING

Possible failure – detection	Probable cause	Possible solution
The electronic plaque does not switch on	Non-powered machine	Reconnect to energy supply source
	Main switch off	Turn on main switch
	Jammed emergency button	Turn to unjam button
	Damaged electronic plaque	Replace electronic plaque
A function of the electronic plaque does not work	Other electric failure	Request technical support that is accredited by the manufacturer.
	Damaged electronic plaque	Replace electronic plaque
The machine works, lacks power and makes a strange noise	Mechanical part jam	Request technical support that is accredited by the manufacturer.
	Three-phase engines working in two phases.	Reestablish electrical connection
	The belts slide	Stretch belts
All functions are operating, however, the bowl and/or the hook do not rotate	At least one of the engines is damaged or the belts have broken	Request technical support that is accredited by the manufacturer.
	Loose hook in the bowl or touching the bowl	
The bowl wiggles too much while simply kneading	Bent hook; fractured; bent bowl or damaged stabilising system of the bowl.	Tune or replace rollers
	Damaged or untuned rollers	

The bowl wiggles too much (even when it is empty)	Damaged stabilising system of the bowl.	Request technical support that is accredited by the manufacturer.
"Squeaking" type of noise	Damaged roller or equipment lacking lubrication	
The chassis wiggles too much	Anti-vibrating supports not tuned	Adjust anti-vibrating supports
The machine operates according to control, the movements are blocked and the noise is loud	A mechanical equipment has been damaged, or an object between the bowl and the hook has broken.	Check and remove the object which does not belong in the bowl, if necessary, request technical support that is accredited by the manufacturer.
Does not reverse the bowl (optional)	Electrical system damaged	Request technical support that is accredited by the manufacturer.
No water comes out of the discharge tube (optional)	The machine does not have water feeding or is obstructed.	Assure the correct water supply
The front of the electronic plaque is torn or punctured	Use of pointy or cutting objects	Replace the electronic plaque
Paint job oxidation	Abrasive environment or use of inadequate products or cleaning methods.	Request technical support that is accredited by the manufacturer.
Other non-described failure	Unknown	

3.6 - PROTECTION MEASURES

The user must comply with all the necessary protection measures that apply. Thus, possible dust must be prevented by using a work overall and avoid dough contamination by protecting all capillary body parts.

Staring at the dough during kneading for over thirty seconds is unadvisable, as it may eventually lead to stress, fatigue or temporary loss of balance.

3.7 - ACCESSORIES AND TOOLS

This machine does not need any accessories or tools for operating or mounting. When cutting the kneaded dough, prevent scratches to the bowl. The use of metallic spatulas as other metallic cutting objects is forbidden.

3.8 - MACHINE STABILITY

Conditions under which the machine complies with the stability requisite:

Phases	Conditions
Transportation and mounting	According to the specific information in the chapter on transportation, mounting, installation and connection within this manual.
Usage	According to specific information on assembling in this manual According to specific information in the chapter on maintenance.
Dismounting	On dismounting operations it is mandatory that the machine is on work position.
Out of service	When out of service, the machine must be in working position. The pavement must not be sloping or slippery. The machine does not need to be screwed to the floor.
During testing	When testing load the above described is applicable.
During possible failures	In case of power or dough bowl failure, do not try to move the hook or the bowl, it is necessary to manually discharge the dough or re-establish power. In any case, inform technical support and hold, the machine will not be damaged.

CHAPTER 4

PROPERTIES OF THE MACHINE

4.1 - MECHANICAL PROPERTIES

The structure has standard or special order measures, to match its purpose.

Made of steel, standard physical-chemical or special order characteristics.

The materials that are in straight contact with the dough do not offer any hazard of contamination or change of its properties.

Mechanical transmissions are performed by speed variation belts and analogical or digital control.

4.2 - ELECTRICAL PROPERTIES

This machine has been manufactured according to characteristics on the nameplate.

Check annex to this manual for the electrical scheme.

The electrical system has been tested according to the applicable legislation and the test record is part of this manual.

Only Technical Support that is accredited by the manufacturer is qualified to work the electrical part. All necessary precautions must always be taken so as to reduce fire, electrical shocks and personal damage hazard, always in compliance with the following norms:

1. Stopping the machine.
2. Turning off main switch.
3. Disconnecting power cable.
4. Performing the necessary maintenance or repairing operations and only then,
5. Re-switching the machine to the power supply.

4.3 - MACHINE CAPACITY

The maximum capacity of kneaders is measured by the maximum capacity of the bowl in terms of kilograms of flour, that is, a model labelled with the example information of "xxx080" can knead up to 80 kg of flour, this rule applying to any model. Usually this rule is applicable to 50% hydration type 65 wheat flour.

The minimum amount to be kneaded is about 5% the total capacity of the bowl, (50% hydration type 65 wheat flour).

To knead below 50% hydration, reduce the maximum capacity of the bowl in 20%.

To knead water dough, the amount of flour must be reduced so as for everything to be involved during the mixing process without loss. Kneading can be performed above 100% hydration. The dough is homogenous, well oxygenated and velvety. Dough does not suffer overheating.

4.4 - SECURITY SYSTEM

The potentially most dangerous part of the machine is the tool area, however, the user is not exposed to hazard on accounts for the solutions incorporated in the equipment:

- The safety grid must be closed for the machine to operate;
- When the safety grid is open, the hook and bowl stop for an equal or greater period of time than the defined in the applicable directives;
- The general outer protection index of the machine is IP20 or greater if by special order.
- Protection lids or other security measure can only be removed by using tools.

If any security system component is noticed to be inoperative, turn off the main switch and call the manufacturer on the phone for technical support.

4.5 - PRECAUTION WITH TOOLS

One of the potentially dangerous areas of the machine is the hook while operating within the bowl.

The user does not need to have straight access to this area so it is protected by the grid when standard operating.

4.6 - PRECAUTION WITH BELTS

The user does not need to have straight access to the belts area, as it is not part of the user's regular work. This area is protected by rigid screwed lids.

4.7 - NOISE EMISSION

The use of specific manufacturing techniques sustains an average sound pressure, considered in A, lower than 70dB, in compliance with ISO directive 3744: "Acoustic. Determination of sound power

levels of noise sources using sound pressure. Engineering method in an essentially free field over a reflecting plane.”

4.8 - RADIATION EMISSION

The machine does not produce any sort of radiation, including ionizing and non-ionizing radiations that may hazard the user's or exposed people's health, including cases involving active or non-active implanted medical devices.

4.9 - LIFE CYCLE OF TEH PRODUCT

<p>CAUTION</p> 	<p>Do not place debris of the components of the machine together with domestic waste.</p>
---	--

During the life cycle of the product, whether it is an inspection operation, maintenance or disposal of this machine, the manufacturer is responsible for the treatment of any piece, component or material at any phase. The life cycle management must always be made by the manufacturer, the only to be held responsible for this management if duly informed for it.

This management firstly considers the possible repair and later reuse of any piece, component or material, however, should that not be possible, redirection to duly accredited residue management must be done, always keeping recycling as a priority. Taking this into consideration, the manufacturer shall deliver into the market highly recyclable equipment.

Directives of different countries must always be taken into consideration, each case having to be regarded separately.



This equipment has the recycling symbol. This means all residues must be separated per type and deposited in an adequate place for residue collection, never included in domestic waste.

This attitude is environmentally friendly and beneficial to all in present and coming generations.

**CHAPTER 5
MAINTENANCE**

<p>CAUTION</p> 	<p>Turn off the main switch and power cable before each cleaning or maintenance operation.</p>
---	---

Whenever potentially dangerous operations are performed, such as mechanic tunings, maintenance, dismantling, electrical components replacement, mechanical or other type, the user must assure the electrical power cable is correctly unplugged.

The internal mechanical components of the machine may eventually offer some mechanical residual hazard. To handle these components wear adequate protection gloves.

<p>CAUTION</p> 	<p>Do not run the machine until all lids, security devices and protection have been set.</p>
---	---

In case of a request to the manufacturer, please offer the information on the nameplate of the machine. Check the annex for the repairing pieces or maintenance applicable to this machine.

5.1 - WHEN THE MACHINE IS NEW

Proceed to a cleaning operation, as described in the daily cleaning topic of this manual.

Even after the cleaning, it is convenient to test the functioning before starting manufacturing, using ingredients that are not to be consumed by people. Thus, packaging, transportation and installation residues can be removed.

5.2 - EVERYDAY

5.2.1 - Machine cleaning

The machine cleaning frequency must be adjusted according to the work hours and the severity of the product. Following is a suggested cleaning frequency table according to the work load:

Number of 8 hour shifts	Cleaning frequency within 24 hours
1	One cleaning procedure every 24 hours
2	One cleaning procedure every 8 hours
3	

The machine must be clean after the operation, on the grid, the inside of the bowl and the hook. On these areas, a diluted disinfectant recommended by the manufacturer must be used, followed by abundant rinsing and drying with an absorbent paper or dry cloth.

The water temperature must range between 55°C and 60°C.

In the other outer parts of the machine a vacuum cleaner, a slightly wetted cloth or soft sponge may be used, taking care not to cause leakage. In the end proceed to the drying by using dry absorbent paper or cloths.

On the inside of the machine, a vacuum for solid and dusty residues can be used.

<p>CAUTION</p> 	<p>Do not use knives, sandpaper, metallic objects, abrasive, toxic or solvent products, or any other sort that may damage the surface or leave residue that may result in product contamination.</p> <p>Do not use jets of water to clean the machine.</p>
---	--

To facilitate cleaning inside the bowl, a water drain may be used for the cleaning water (optional function):

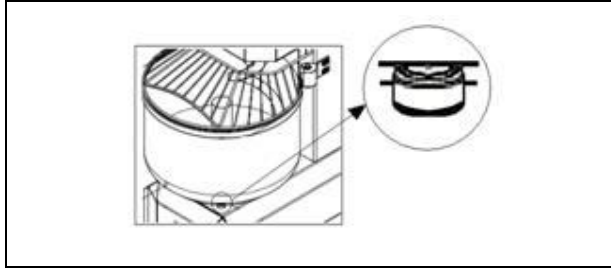

Stop the machine so as for the drain to be in proper position for draining cleaning water. Prevent the water from sliding down the inner parts of the machine by placing a vessel under the drain in order for all the cleaning water to be held.

The lid of the drain is manually placed by the manufacturer, without any need for a spanner or wrench system.

After the cleaning, place the lid manually on the drain so as to prevent a leakage of the product the next usage.

The materials in contact with the dough are entirely innocuous, they do not affect the product. Following are some merely informative examples of possible hygiene failures after visual inspection or microbiologic analysis, its causes, detection means and its effect and control:

Effect	Cause	Control
Dirt by protein coagulation	The water is too hot, Temperature higher than 60°C	Use water ranging from 55°C to 60°C.
Dirt by grease development	Not too hot water, not so effective in grease elimination Temperature less than 55°C	Use water ranging from 55°C to 60°C.
Dirt with limestone deposit	Too much hard water ($\geq 10^{\circ}\text{fH}$)	Use less hard water
Dirt accumulation, harder removal	Long intervals between cleanings	Shorter intervals between cleanings or more intense cleaning
Residual dirt	Incorrect rinsing	Rinse well
Initial dirt still visible	The disinfectant did not act for enough time which affected its outcome	Check cleaning procedure
	Too diluted disinfectant	Check disinfectant preparation procedure
	Inappropriate disinfectant	Select correct disinfectant
Dripping water containing microorganisms dirt	Residual humidity	Assure proper drying Assure draining to the equipments and facilities

5.2.2 - SECURITY SYSTEM CHECK

The security systems of this machine assure people, property and animals security under any circumstance. To check the operability of these systems, before the start of each shift, proceed in the following way:

Check if the protection lids are operational. If not, re-establish functionality.

Set the machine to manual mode;

Open the grid entirely;

The machine must switch itself off when the grid begins to be open. Should that not happen, turn it off on the main switch and call the technical support of manufacturer.

If the grid is operational, close it and get the machine working again; Press the emergency button;

The machine must switch itself off and remain as such keeping the emergency button locked. Should this not happen, turn the machine off on the main switch and call the technical support of the manufacturer.

5.3 - EVERY SIX MONTHS

Check frequency according to work load:

Number of 8 hour shifts	Check frequency every 6 months
1	One check on the 6th month
2	One check every 3 months
3	One check every 2 months

5.3.1 - Belts check

The belts stretching must be performed by a technician who is duly accredited by the manufacturer.

In case of need, depending on the elevation or machine installation, to access the upper-lid area a ladder or other elevation equipment must be used, assuring directives and other current legislation regarding elevation of people is respected.

Should belts need stretching, proceed as follows:

Turn off the main switch of the machine;

Disconnect the power supply cable;

Unfasten the screws on the lid;

Stretch the belts until they comply with the following picture.

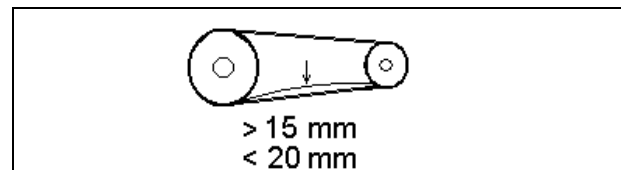

Hook transmission belt:

Access of obtained via the top lid of the machine.

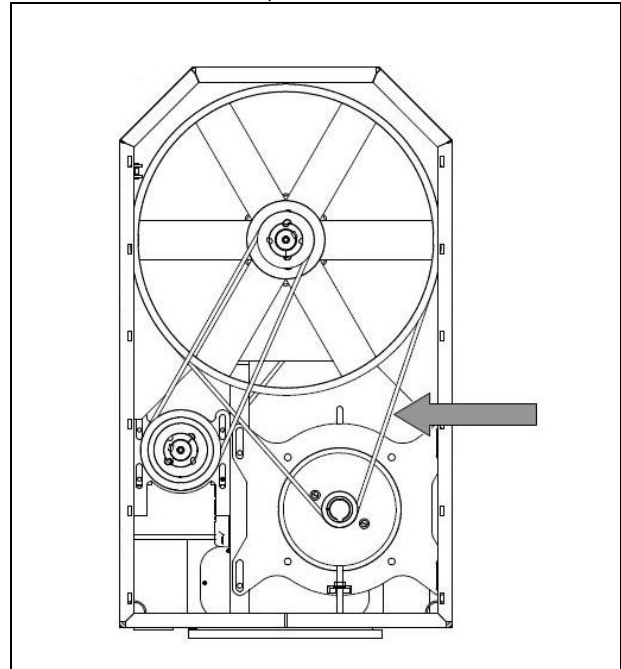

Loosen slightly the screws indicated in the figure.

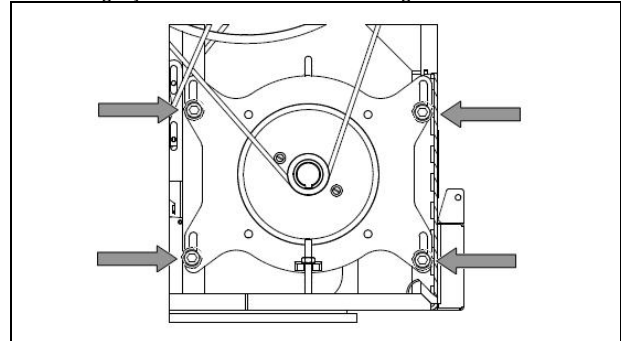

Adjust the stretchers indicated in the figure.

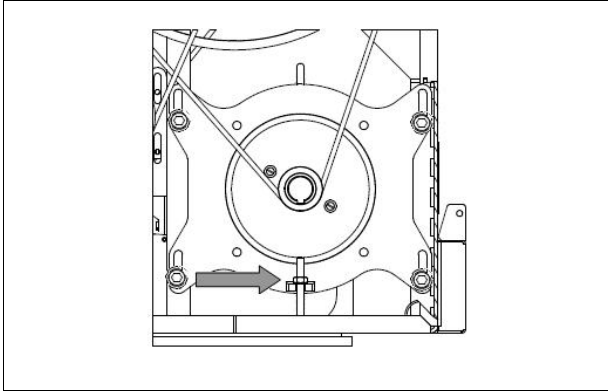

At the end, tighten the screws indicated in the figure.

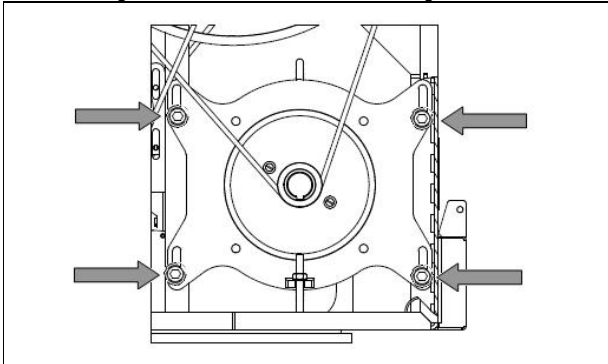

Bowl transmission belts – level 1:
Access of obtained via the top lid of the machine.

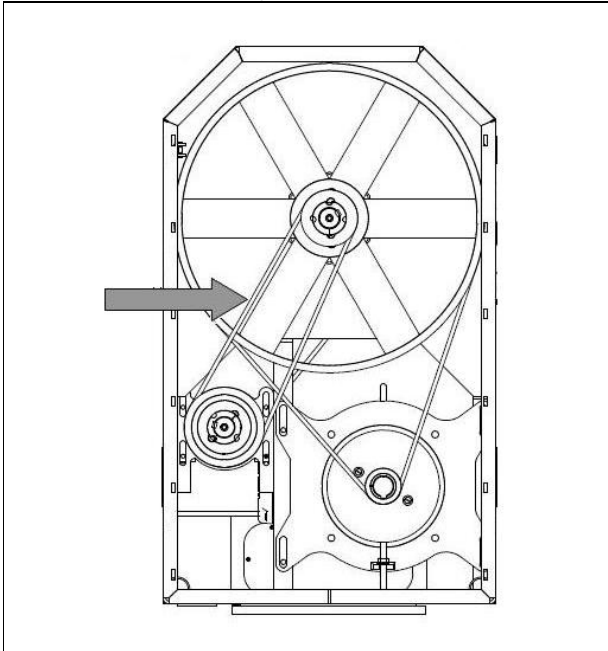

Loosen slightly the screws indicated in the figure.

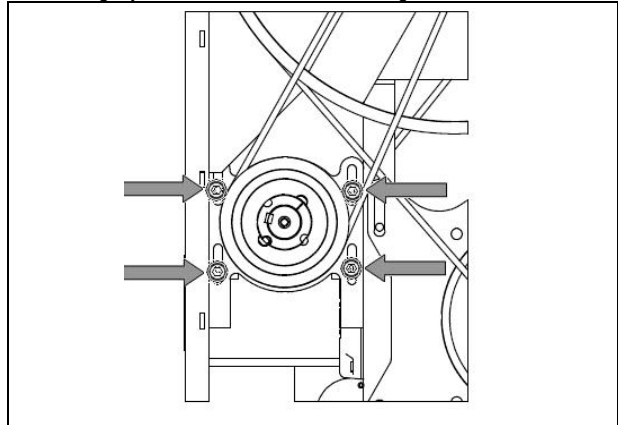

Adjust the stretchers indicated in the figure.

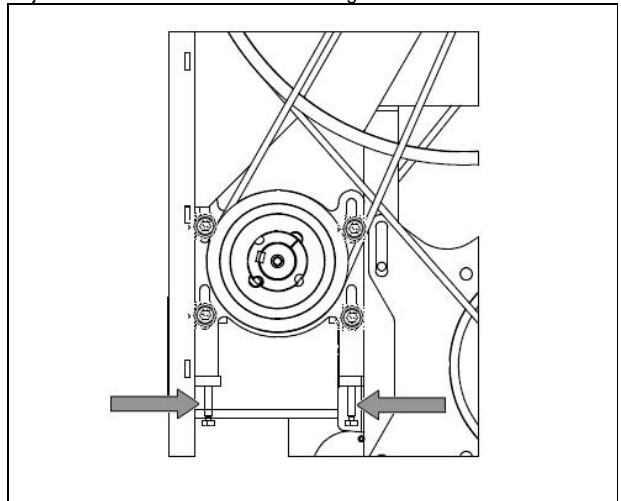

At the end, tighten the screws indicated in the figure.

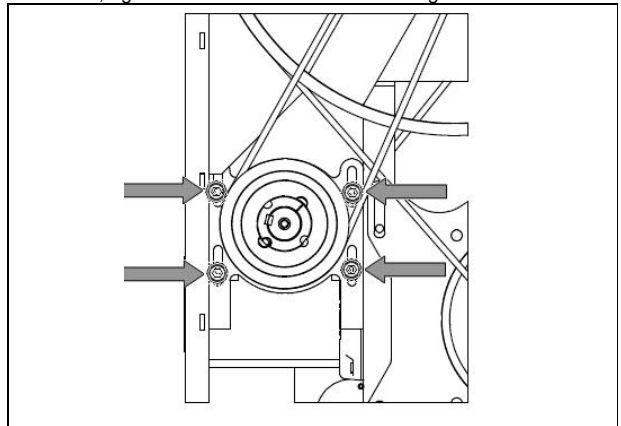

Bowl transmission belts – level 2:

Access of obtained via the bottom lid of the machine.

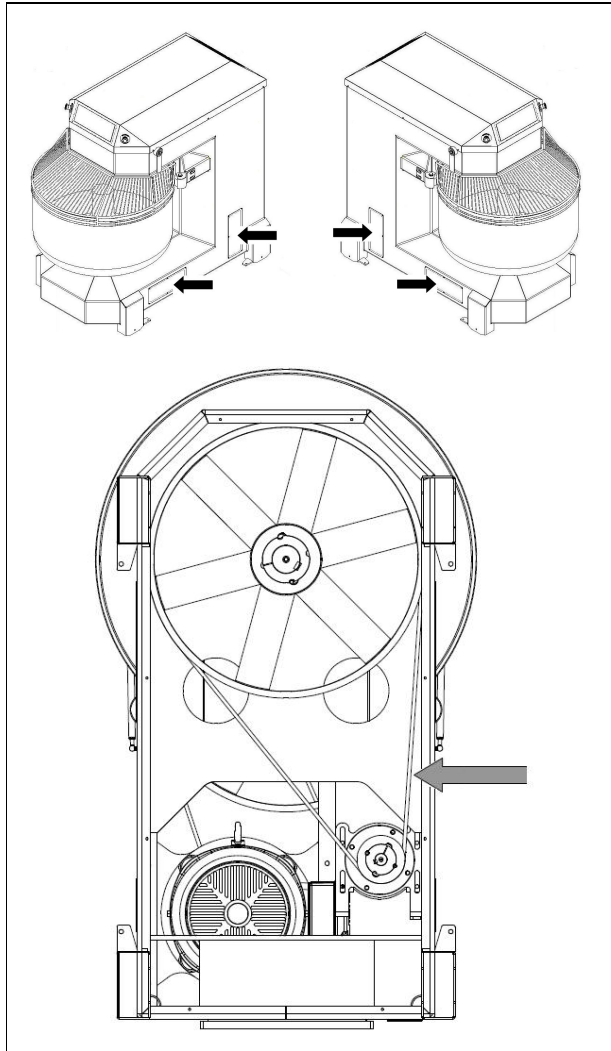

Loosen slightly the screws indicated in the figure.

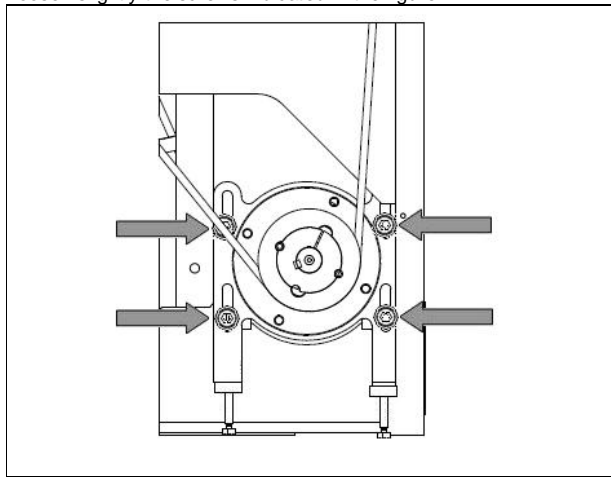

Adjust the stretchers indicated in the figure.

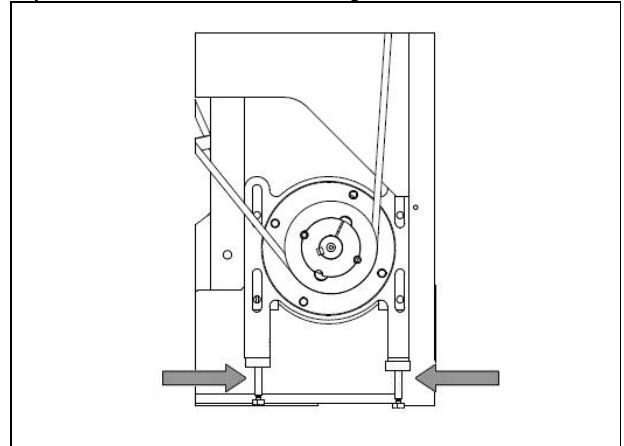

At the end, tighten the screws indicated in the figure.

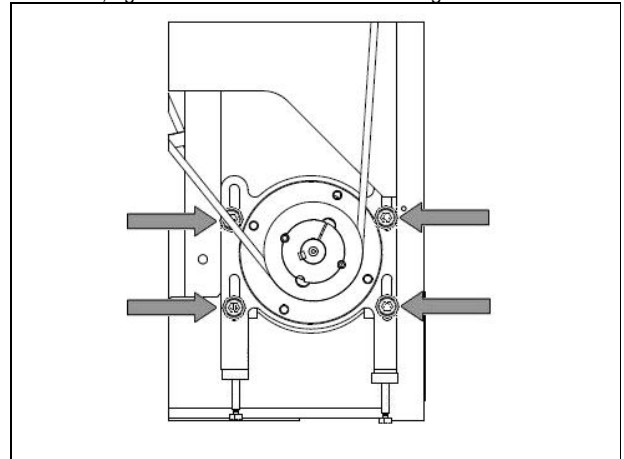

Should a belt be broken, all must be replaced, not simply the one that has been broken. When replacing all belts, use complete sets of the same manufactured series.

Re-check the belts and repeat the procedure once again.

Fasten the screws of the lid.

Depending on the usage frequency and effort put upon the machine, this period must be adjusted to what is considered convenient. The higher the usage frequency or effort, the lesser the interval between these checks must be.

5.3.2 - Bowl rollers check

Loosen slightly the screws indicated in the figure

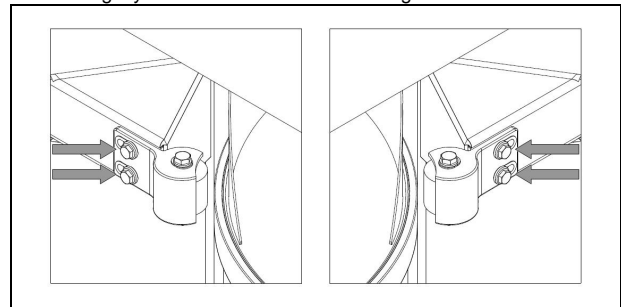

Adjust the 2 rolls so that there isn't too much pressure between the bowl and the roller. The function of the roller is to support the bowl and not push the bowl.

After tightening the screws, put the machine working.

CAUTION

Caution: when moving, the rollers have a residual risk of getting caught on upper limbs..

The rollers must be tuned so that, in a complete turn of the bowl each roller stops rotation at least once. This way each roller has enough space in relation to the bowl.

If this does not happen, turn off the general switch and electricity supply cable and repeat the tuning sequence.

5.3.3 - General tuning and lubrication check

The bowl rollers adjustment must be performed by a technician who is duly accredited by the manufacturer.

5.3.4 - Machine fixation check

Check the fastening of all the anti-vibration supports. Adjust if necessary.

