



www.BakeMax.com

Project: _____

Item: _____

Qty: _____ Date: _____

BakeMax BMPM060 – 60 Qt Heavy Duty Planetary Mixer



The BakeMax BMPM060 – 60 Qt Heavy Duty Planetary Mixer provides durability, long life and excellent mixing performance. They are safe, easy to use and capable of a broad range of dough and food mixing applications.

Features:

- 100% gear driven
- #12 hub for meat grinder / vegetable cutter attachment
- 3 HP motor offers enough power to mix stiffer doughs and larger batches
- 15 minute manual timer
- All metal and die-cast aluminum body
- Transmission is made of hardened alloy steel gears
- All shafts are mounted in ball bearings
- Manual 4 speed control (84 / 148 / 248 / 436 RPM)
- Planetary mixing action ensures perfect results
- Hydraulic bowl lift
- Includes dough hook, flat beater and wire whip
- Safety guard is standard for model BMPM060 and provides with automatic shut-off when guard is opened at any speed
- Emergency stop button
- 2 year limited warranty



Intertek



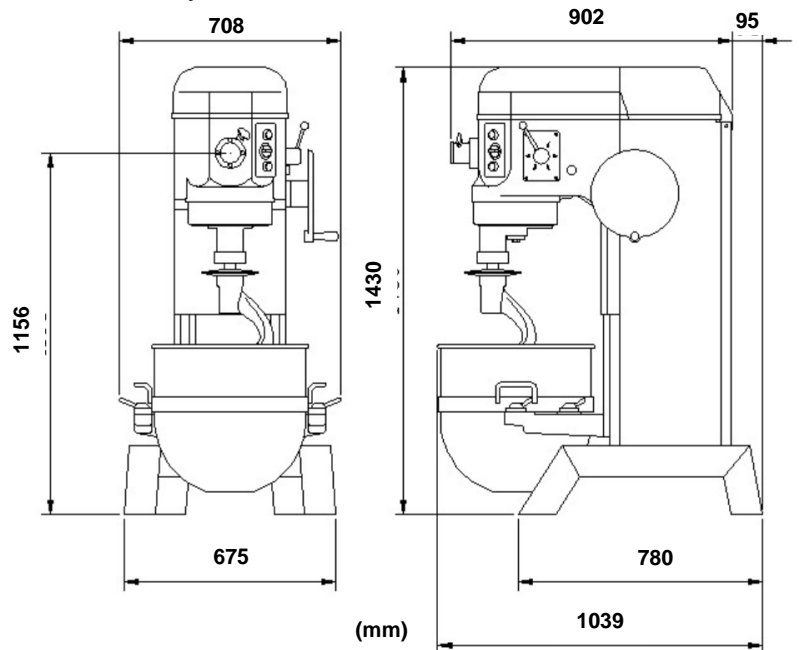

Intertek



** Due to continuous product improvement, specifications are subject to change without notice.

BakeMax® / Titan Ventures International Inc.

Warehouses:

270 Baig Blvd, Suite A3, Moncton, NB E1E 1C8 
1605 Crescent Circle, Dallas, TX 75006 

Toll Free: 1-800-565-BAKE (2253)

Phone: 506-858-8990

Fax: 506- 859-6929

Email: Sales@BakeMax.com

Technical Specifications:

- Exterior Dimensions (WDH): 28" x 41" x 57"
- 220v / 24 amps / 2250 watts / 60Hz / 1Ph
- Nema: Hard Wired
- Net Weight 1003 lb

Shipping Specifications:

- Packaged Dimensions (WDH): 33" x 47" x 66" H
- Packaged Weight 1176 lb

Mixing Dough & Capacity Information

The moisture content of heavy dough is a critical factor when selecting proper mixing speed. You should never use 2nd speed when mixing heavy dough with an Absorption Ratio (AR) of 50% or less. To determine the Absorption Ratio (AR) of a product, divide the water weight by the flour weight.



Example: Calculate the Absorption Ratio of a mixture containing 10 lbs. Of flour and 5 lbs. of water.

$$10 \div 5 = 0.50 = 50 \% = \text{AR}$$

PRODUCT	TOOL	BOWL CAPACITY: 60 QT
Egg Whites	Whip	2 qt
Mashed Potatoes	Beater	40 lb
Mayonnaise (Qt Oil)	Beater	18 qt
Meringue (Qt Water)	Whip	1.5 qt
Waffle/Pan cake Batter	Beater	24 qt
Whipped Cream	Whip	12 qt
Cup Cake	Beater	59.53 lb
Layer Cake	Beater	59.53 lb
Sugar Cookie	Beater	39.68 lb
Bread or Roll Dough (Light/ Medium, 60% AR, =)	Hook 2 nd Speed	80 lb (Total Dough)
Bread or Roll Dough (Heavy, 55% AR, =)	Hook 2 nd Speed	60 lb (Total Dough)
Thin Pizza Dough, Pasta, Basic Egg Noodle(40% AR, =, 5 min. max. mix time)	Hook 1 st Speed	50 lb (Total Dough)
Medium Pizza Dough (50% AR, =)	Hook 1 st Speed	80 lb (Total Dough)
Thick Pizza Dough (60% AR, =)	Hook 2 nd Speed	80 lb (Total Dough)
Raised Donut Dough (65% AR)	Hook 1 st Speed	80 lb (Total Dough)
Whole Wheat Dough (70% AR)	Hook 2 nd Speed	80 lb (Total Dough)

Warning: If using high gluten or rice flour, please reduce capacity by 10%. This chart should be used as a guide. Type of flour and other factors can vary and may require batch size to be adjusted.

BakeMax ® / Titan Ventures International Inc.**Warehouses:**

270 Baig Blvd, Suite A3, Moncton, NB E1E 1C8 
1605 Crescent Circle, Dallas, TX 75006 

Toll Free: 1-800-565-BAKE (2253)

Phone: 506-858-8990

Fax: 506- 859-6929

Email: Sales@BakeMax.com